

■ General Description

A digital camera requires individual supply voltages for LCD, CCD, backlight, focus, and other blocks. One or two lithium-ion cells and three or four alkali dry cells are used as power sources. High-efficiency DC/DC converters capable of performing individual ON-OFF control are used as power ICs for these power sources. The block diagram shown at right represents principal power supply systems used in a digital camera. The Torex DC/DC converter IC series, featuring high efficiency and low current consumption, meet requirements of these power supply systems. Examples of power supplies are shown below for each block.

■ Principal Blocks

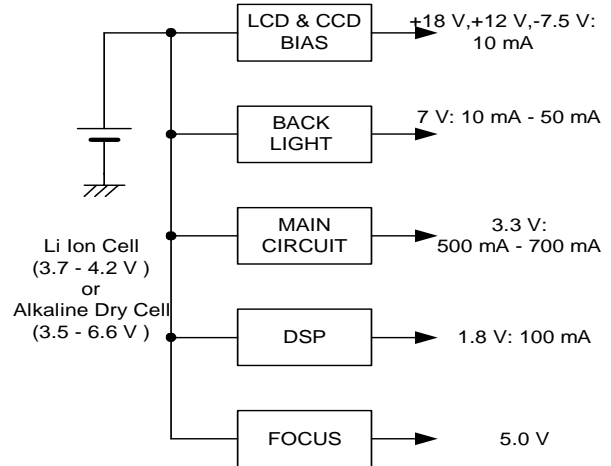

■ Circuits

Fig. 1 Circuit for LCD & CCD

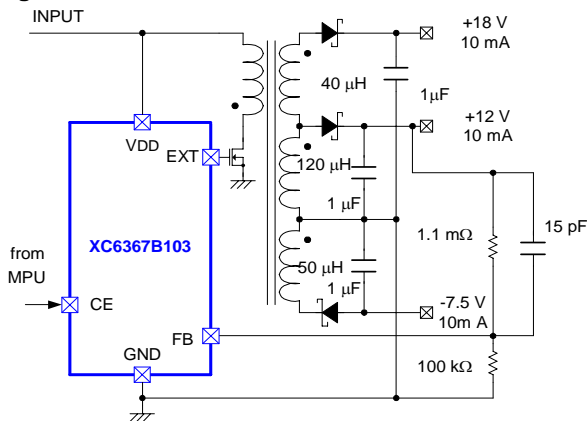

This example incorporates a flyback transformer. Output voltages are determined by turn ratios. A negative voltage is also available from this circuit. The combination of a step-up DC/DC converter and a diode charge pump is also used in a simplified configuration.

Fig. 3 Circuit for Main Power Supply

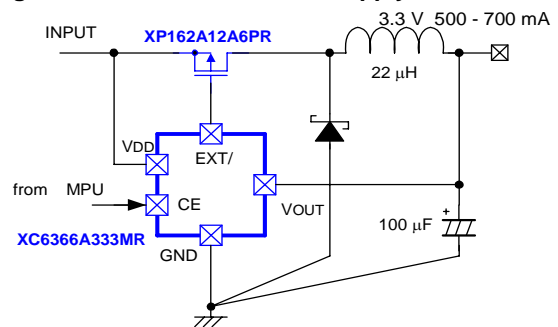

A PWM system is used due to its high efficiency and excellent ripple characteristics to deliver high power. Specifically, the PWM/PFM automatic selection type is used to improve efficiency under light load condition.

Fig. 2 Circuit for Backlight

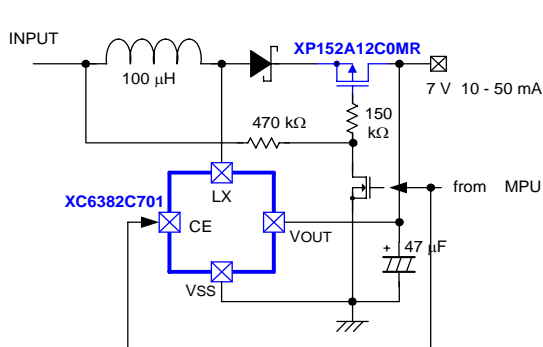

This is an example of using an inexpensive PFM DC/DC converter to drive white LEDs. Improved efficiency is achieved and variation of brightness is eliminated by means of constant-current drive incorporating a PWM step-up DC/DC converter of the FB type (for example, the XC6367).

Fig. 4 Circuit for DSP

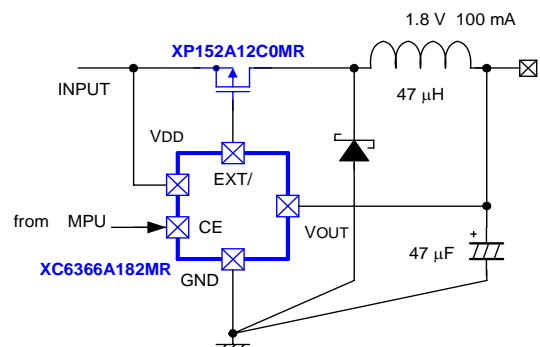

Low-voltage local supplies have been increasingly in use in accordance with decreasing IC operating voltages. Torex ICs are optimal for individual local supplies as shown above, as well as for other applications.