

800mA Single Cell Li-ion Battery Linear Charger IC

GENERAL DESCRIPTION

The XC6802 series is a constant-current/constant-voltage linear charger IC for single cell lithium-ion batteries. The XC6802 includes a reference voltage source, battery voltage monitor, driver transistor, constant-current/constant-voltage charge circuit, over heat protection circuit, phase compensation circuit. The battery charge termination voltage is internally set to $4.2V \pm 0.7\%$ and the trickle charge voltage and accuracy is $2.9V \pm 3\%$. In trickle charge mode, a safe charge to a battery is possible because approximately 1/10 out of setting charge current is supplied to the battery. With an external R_{SEN} resistor, the charge current can be set freely up to 800mA (MAX.), therefore, the series is ideal for various battery charge applications. The series' charge status output pin, /CHG pin, is capable of checking the IC's charging state while connecting with an external LED.

APPLICATIONS

Charging docks, charging cradles
 MP3 players, portable audio players
 Cellular phones, PDAs
 Bluetooth headsets

FEATURES

Operating Voltage Range	: 4.25V ~ 6.0V
Charge Current	: Externally set up to 800mA (MAX.)
Charge Termination Voltage	: $4.2V \pm 0.7\%$
Trickle Charge Voltage	: $2.9V \pm 3\%$
Supply Current (Stand-by)	: $15 \mu A$ (TYP.)
Function	: Constant-current/constant-voltage Operation Thermal Shutdown Automatic Recharge Charge Status Output Pin Soft-start Function (Inrush Limit Current)
Operating Ambient Temperature	: $-40 \sim +85$
Packages	: SOT-89-5, SOT-25, USP-6C, USP-6EL
Environmentally Friendly	: EU RoHS Compliant, Pb Free

TYPICAL APPLICATION CIRCUIT

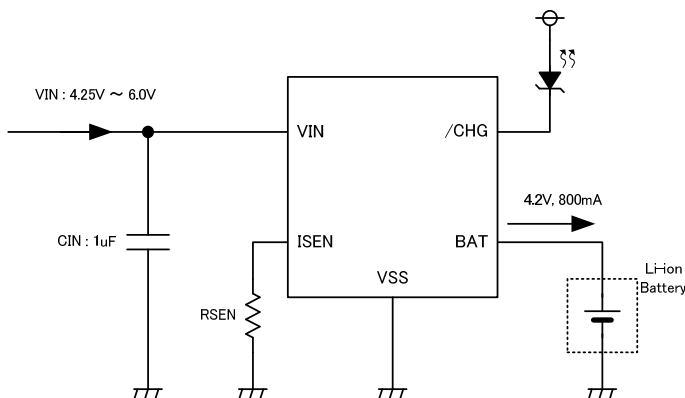

TYPICAL PERFORMANCE CHARACTERISTICS

Battery Charge Cycle

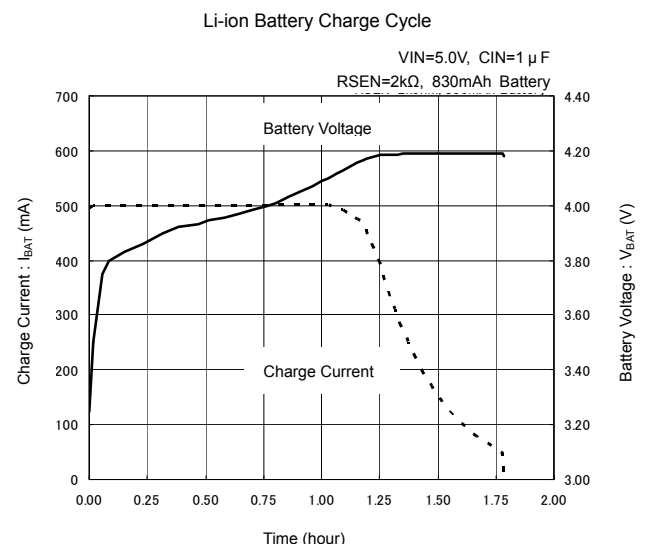

PIN CONFIGURATION

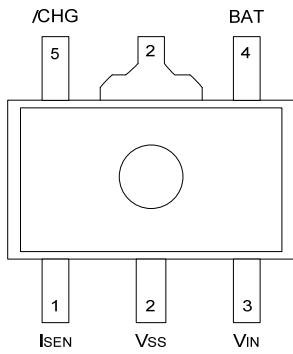

SOT-89-5
(TOP VIEW)

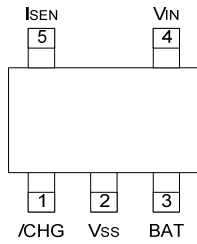

SOT-25
(TOP VIEW)

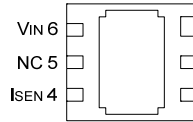

USP-6C
(BOTTOM VIEW)

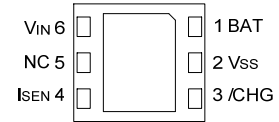

USP-6EL
(BOTTOM VIEW)

* The dissipation pad for the USP-6C / USP-6EL package should be solder-plated in recommended mount pattern and metal masking so as to enhance mounting strength and heat release. If the pad needs to be connected to other pins, it should be connected to the V_{SS} (No. 2) pin.

PIN ASSIGNMENT

PIN NUMBER				PIN NAME	FUNCTIONS
SOT-25	SOT-89-5	USP-6C	USP-6EL		
1	5	3	3	/CHG	Charge Status Output Pin
2	2	2	2	V _{SS}	Ground
3	4	1	1	BAT	Charge Current Output Pin
4	3	6	6	V _{IN}	Input Voltage Pin
5	1	4	4	I _{SEN}	Charge Current Setup Pin
-	-	5	5	NC	No Connection

FUNCTIONS

XC6802A42X

PIN NAME	CONDITIONS	IC OPERATION
I _{SEN}	H Level ($1.4V \leq V_{SEN} \leq V_{IN}$) or Open	OFF (Shutdown Mode)
	Pull-down by external components	ON, Charge Current I _{BAT} =1000 / R _{SEN} *

* For SOT-25, SOT-89-5, and USP-6C, charge current should be set to become I_{BAT} ≤ 800mA.
For USP-6EL, charge current should be set to become I_{BAT} ≤ 500mA.

PRODUCT CLASSIFICATION

Ordering Information

XC6802A42X -③

DESIGNATOR	ITEM	SYMBOL	DESCRIPTION
-③ ^(*)	Packages (Order Unit)	PR	SOT-89-5 (1,000/Reel)
		PR-G	SOT-89-5 (1,000/Reel)
		MR	SOT-25 (3,000/Reel)
		MR-G	SOT-25 (3,000/Reel)
		ER	USP-6C (3,000/Reel)
		ER-G	USP-6C (3,000/Reel)
		4R-G	USP-6EL (3,000/Reel)

^(*) The "-G" suffix denotes Halogen and Antimony free as well as being fully RoHS compliant.

ELECTRICAL CHARACTERISTICS

XC6802A42x

Ta=25

PARAMETER	SYMBOL	CONDITIONS	MIN	TYP	MAX	UNIT	CIRCUIT
Input Voltage	V _{IN}		4.25	-	6.0	V	-
Supply Current	I _{SS}	Charge mode, R _{SEN} =10kΩ	-	15	35	μA	
Stand-by Current	I _{STBY}	Stand-by mode	-	15	35	μA	
Shut-down Current	I _{SHUT}	Shut-down mode (R _{SEN} =NC, V _{IN} <V _{BAT} or V _{IN} <V _{UVLO})	-	10	23	μA	
Float Voltage 1	V _{FLOAT1}	Ta=25, I _{BAT} =40mA	×0.993	4.2	×1.007	V	
Float Voltage 2 ⁽¹⁾	V _{FLOAT2}	0 Ta 50, I _{BAT} =40mA	×0.99	4.2	×1.01	V	-
Maximum Battery Current ⁽²⁾	I _{BATMAX}	SOT-25 / SOT-89-5 / USP-6C	-	-	800	mA	-
		USP-6EL	-	-	500		
Battery Current 1	I _{BAT1}	R _{SEN} =10kΩ, CC mode	93	100	107	mA	
Battery Current 2	I _{BAT2}	R _{SEN} =2kΩ, CC mode	465	500	523	mA	
Battery Current 3	I _{BAT3}	Stand-by mode, V _{BAT} =4.2V	-	-	2	μA	
Battery Current 4	I _{BAT4}	Shut-down mode (R _{SEN} =NC)	-	-	1	μA	
Battery Current 5	I _{BAT5}	Sleep mode, V _{IN} =0V	-	-	1	μA	
Trickle Charge Current 1	I _{TRIKL1}	V _{BAT} <V _{TRIKL} , R _{SEN} =10kΩ	6	10	14	mA	
Trickle Charge Current 2	I _{TRIKL2}	V _{BAT} <V _{TRIKL} , R _{SEN} =2kΩ	30	50	70	mA	
Trickle Voltage	V _{TRIKL}	R _{SEN} =10kΩ, V _{BAT} Rising	2.913	2.9	2.987	V	
Trickle Voltage Hysteresis Width	V _{TRIKL_HYS}	-	58	90	116	mV	
UVLO Voltage	V _{UVLO}	V _{IN} : L → H	3.686	3.8	3.914	V	
UVLO Hysteresis Width	V _{UVLO_HYS}	-	150	190	280	mV	
Manual Shut-down Voltage	V _{SD}	I _{SEN} : L → H	1.4	-	-	V	
Manual Shut-down Voltage Hysteresis Width	V _{SD_HYS}	-	-	100	-	mV	
$\frac{V_{IN}-V_{BAT}}{V_{IN}-V_{BAT}}$ Shut-down Release Voltage	V _{ASD}	V _{IN} : L → H	70	100	140	mV	
$\frac{V_{IN}-V_{BAT}}{V_{IN}-V_{BAT}}$ Shut-down Voltage Hysteresis Width	V _{ASD_HYS}	-	-	70	-	mV	
C/10 Charge Termination Current Threshold 1	I _{TERM1}	R _{SEN} =10kΩ	0.07	0.10	0.13	mA/mA	
C/10 Charge Termination Current Threshold 2	I _{TERM2}	R _{SEN} =2kΩ	0.07	0.10	0.13	mA/mA	
I _{SEN} Pin Voltage	V _{ISEN}	R _{SEN} =10kΩ, CC mode	-	1.0	-	V	
/CHG Pin Weak Pull-down Current	I _{CHG1}	V _{BAT} =4.3, V _{CHG} =5V	8	20	50	μA	
/CHG Pin Strong Pull-down Current	I _{CHG2}	V _{BAT} =4.0V, V _{CHG} =1V	4	10	20	mA	
/CHG Pin Output Low Voltage	V _{CHG}	I _{CHG} = 5mA	-	0.35	0.7	V	
Recharge Battery Threshold Voltage	ΔV _{RECHRG}	V _{FLOAT1} -V _{RECHRG}	100	150	200	mV	
ON Resistance	R _{ON}	I _{BAT} =100mA	-	450	900	mΩ	
Soft-start Time	t _{SS}		100	150	200	μs	
Recharge Battery Time	t _{RECHRG}		0.4	2	4	ms	
Battery Termination Detect Time	t _{TERM}	I _{BAT} falling (less than charge current /10)	0.3	1	3.5	ms	
I _{SEN} Pin Pull-up Current	I _{SEN_pull_up}	-	-	1.3	-	μA	
Thermal Shut-down Detect Temperature	T _{TSD}	Junction temperature	-	115	-	-	-
Thermal Shut-down Release Temperature	T _{TSR}	Junction temperature	-	95	-	-	-

* Unless otherwise stated, V_{IN}=5.0V.

⁽¹⁾ The figures under the condition of 0°C Ta 50°C are guaranteed by design calculation.

⁽²⁾ The R_{SEN} resistance set: The battery current shall not be exceeded to 800mA. (SOT-25, SOT-89-5, and USP-6C)
The battery current shall not be exceeded to 500mA. (USP-6EL)

OPERATIONAL EXPLANATION

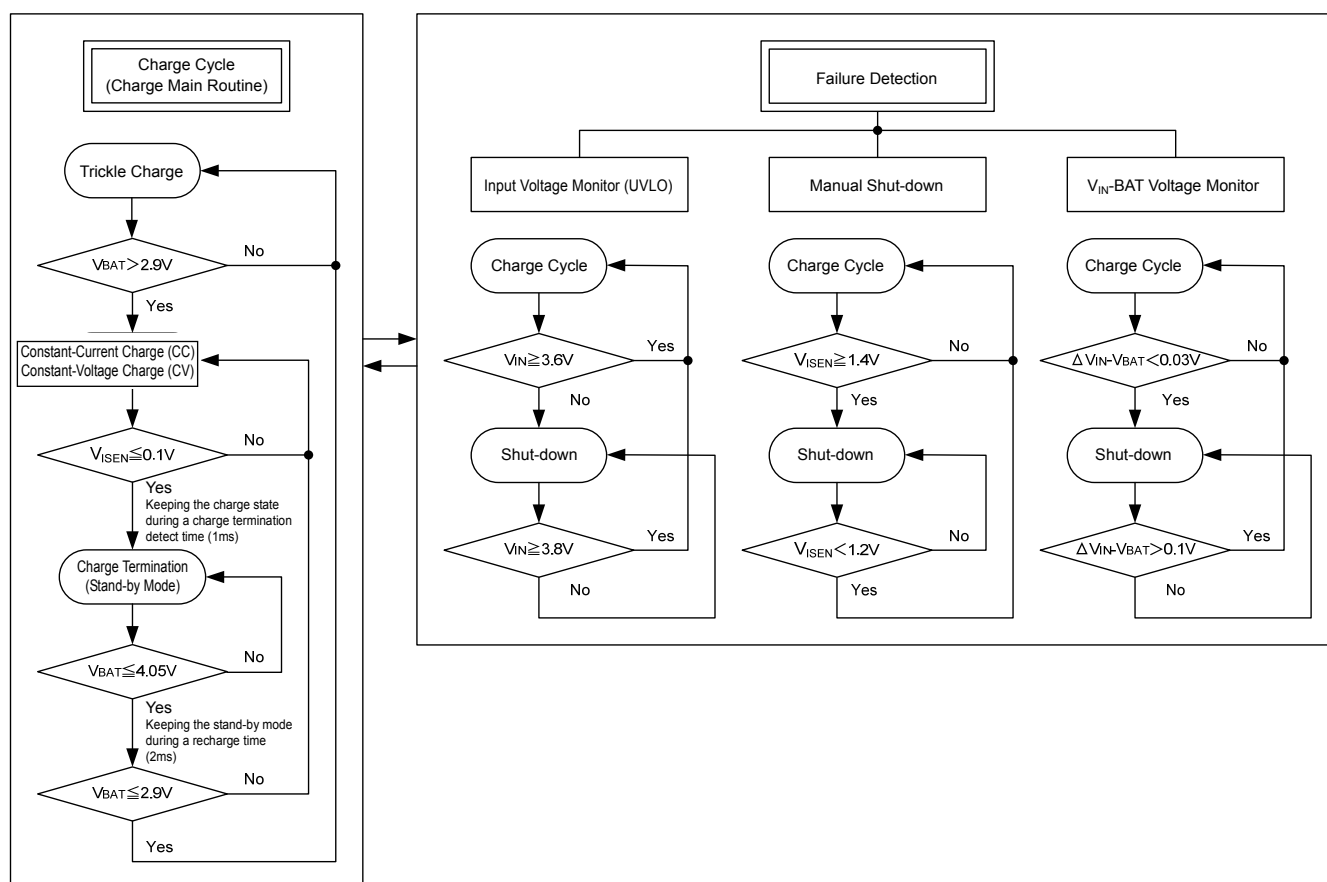

<Charge Cycle>

If the BAT pin voltage is less than trickle voltage (TYP. 2.9V), the charger enters trickle charge mode. In this mode, a safe battery charge is possible because approximately only 1/10 of the charge current which was set by the I_{SEN} pin, is supplied to the battery. When the BAT pin voltage rises above the trickle voltage, the charger enters constant-current mode (CC mode) and the battery is charged by the programmed charge current. When the BAT pin voltage reaches 4.2V, the charger enters constant-voltage mode (CV mode) automatically. After this, the charge current starts to drop and when it reaches a level which is 1/10 of the programmed charge current, the charge terminates.

<Setting Charge Current>

The charge current can be set by connecting a resistor between the I_{SEN} pin and the V_{SS} pin. The battery charge current, I_{BAT} , is 1000 times the current out of the I_{SEN} pin. Therefore, the charge current, I_{BAT} , is calculated by the following equations:

$$I_{BAT} = (V_{ISEN} / R_{SEN}) \times 1000 \quad (V_{ISEN} = 1.0V \text{ (TYP.): Current sense pin voltage})$$

However I_{BAT} 800mA (SOT-25, SOT-89-5, and USP-6C), I_{BAT} 500mA (USP-6EL)

<Charge Termination>

The battery charge is terminated when the charge current decreases to 1/10 of the full charging level after the battery pin voltage reaches a float voltage. An internal comparator monitors the I_{SEN} pin voltage to detect the charge termination. When the comparator monitors the I_{SEN} pin voltage is less than 100mV (charge termination detect)^(*) for 1ms TYP. (charge termination detect time), the IC enters stand-by mode. A driver transistor turns off during the stand-by mode. In this state, a failure detection circuit and a monitoring circuit of the battery pin voltage operates.

^(*) The detect after charging completed: I_{SEN} pin voltage should be less than 100mV.

<Automatic Recharge>

In stand-by mode battery voltage falls. When the voltage level at the battery pin drops to recharge battery threshold voltage (TYP. 4.05V) or less, the charge cycle automatically re-starts after a delay of (TYP. 2ms). As such, no external activation control is needed.

OPERATIONAL EXPLANATION (Continued)

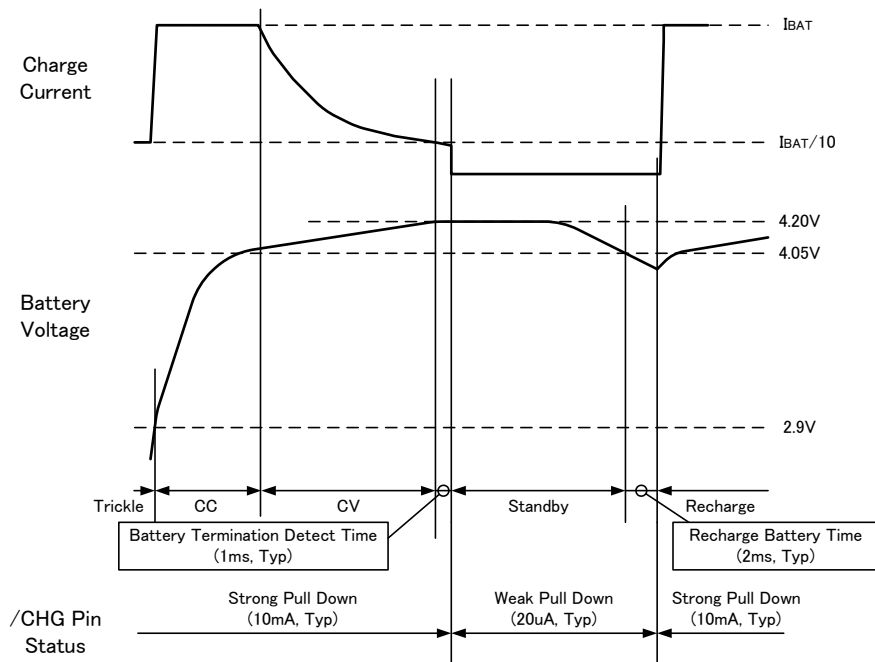

<Charge Condition Status>

The /CHG pin constantly monitors the charge states classified as below:

- Strong pull-down: $I_{CHG}=10\text{mA}$ (TYP.) in a charge cycle,
- Weak pull-down: $I_{CHG}=20\ \mu\text{A}$ (TYP.) in a stand-by mode,
- High impedance: in shutdown mode.

<Connection of Shorted BAT Pin>

Even if the BAT pin is shorted to the V_{SS} , a trickle charge mode starts to operate for protecting the IC from destruction caused by over current.

<Under-voltage Lockout (UVLO)>

The UVLO circuit keeps the charger in shut-down mode until the input voltage, V_{IN} , rises more than the UVLO voltage. Moreover, in order to protect the battery charger, the UVLO circuit keeps the charger in shut-down mode when a voltage between the input pin voltage and BAT pin voltage falls to less than 30mV (TYP.). The charge will not restart until the voltage between the input pin voltage and BAT pin voltage rises more than 100mV (TYP.). During the shut-down mode, the driver transistor turns off but a failure detection circuit operates, and supply current is reduced to 10 μA (TYP.).

<Soft-start Function>

To protect against inrush current from the input to the battery, soft-start time is set in the circuit optimally (150 μs , TYP.).

<Manual Shut-down>

During the charge cycle, the IC can be shifted to the shut-down mode by floating the I_{SEN} pin. For this, a drain current to the battery is reduced to less than 2 μA and a shut-down current of the IC is reduced to less than 10 μA (TYP.). A new charge cycle starts when reconnecting the current sense resistor.

<Opened BAT Pin>

When the BAT pin is left open, the IC needs to be shut-down once after monitoring the CHG pin by a microprocessor etc and keeping the I_{SEN} pin in H level.

<Backflow Prevention Between the BAT Pin and the V_{IN} Pin>

A backflow prevention circuit protects against current flowing from the BAT pin to the V_{IN} pin even the BAT pin voltage is higher than the V_{IN} pin voltage.

■ NOTES ON USE

1. For temporary, transitional voltage drop or voltage rising phenomenon, the IC is liable to malfunction should the ratings be exceeded.
2. Where wiring impedance is high, operations may become unstable due to noise and/or phase lag depending on output current. Please wire the C_{IN} as close to the IC as possible.
3. Torex places an importance on improving our products and their reliability.
We request that users incorporate fail-safe designs and post-aging protection treatment when using Torex products in their systems.

TEST CIRCUITS

1. ON Resistance, Shut-down Voltage, I_{SEN} Pull-up current

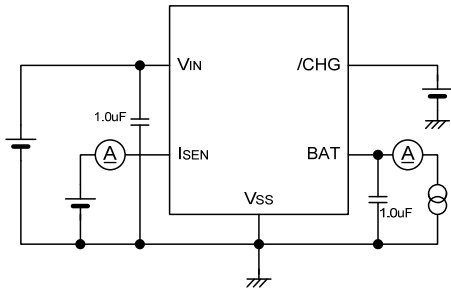

2. Battery Termination Detect Time, Recharge Battery Time
C/10 Charge Termination Current Threshold 1 ~ 2,
Battery Termination Voltage 1

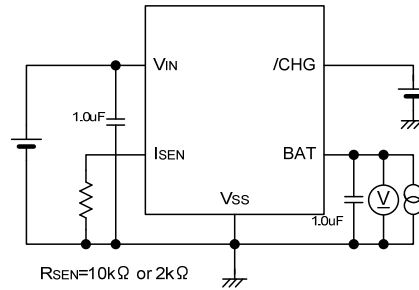

3. Trickle Charge Current 1 ~ 2, Battery Current 1 ~ 3, Battery Current 5
 I_{SEN} Pin Voltage, Trickle Charge Voltage, UVLO,
Recharge Battery Threshold Voltage
 $V_{IN} - V_{BAT}$ Shut-down Release Voltage, /CHG Pin Weak Pull-down Current
/CHG Pin Strong Pull-down Current, Stand-by Current, Shut-down Current

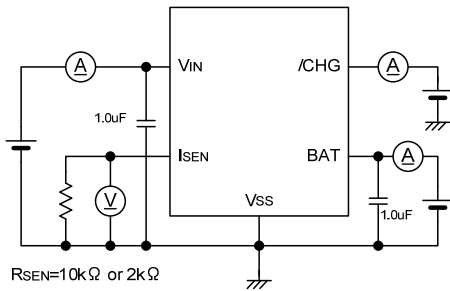

4. /CHG Pin, Output Low Voltage

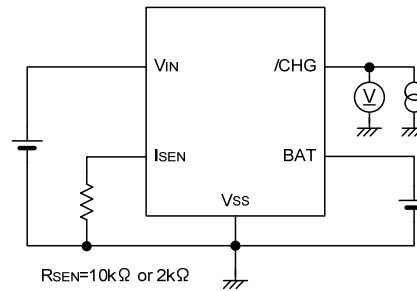

5. Battery Current 4

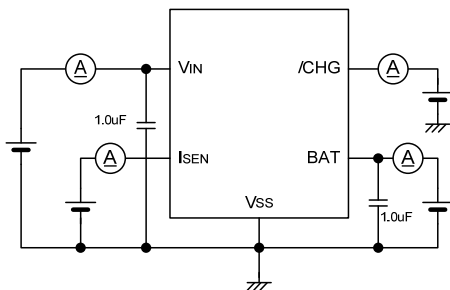

6. Soft-start

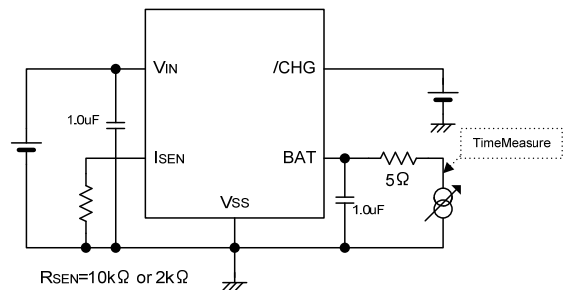

TYPICAL PERFORMANCE CHARACTERISTICS

(1) Charge Cycle

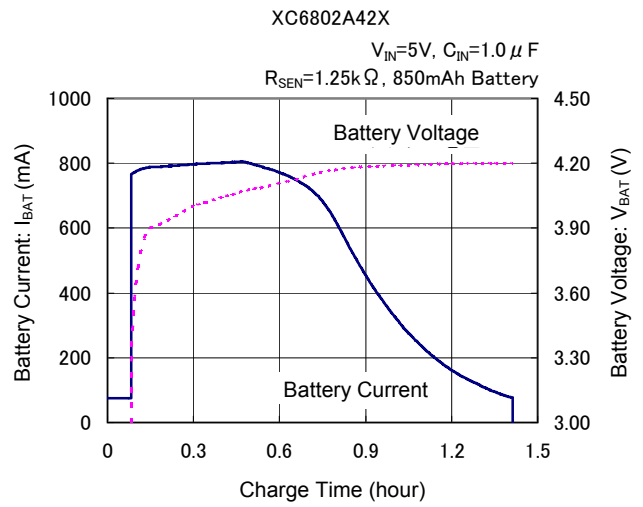
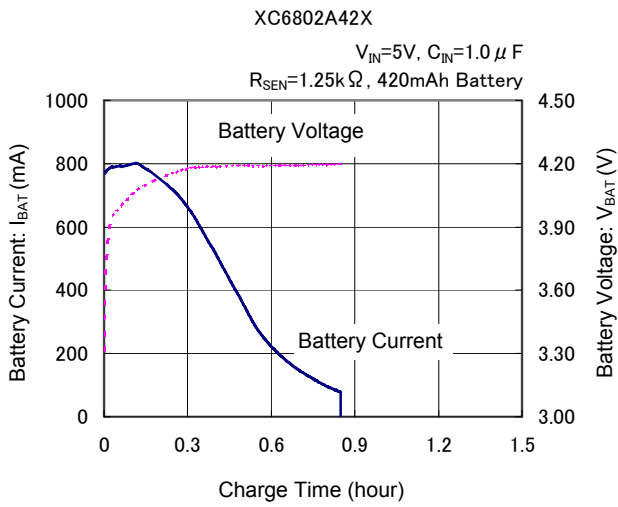

(2) Battery Current vs. Battery Voltage

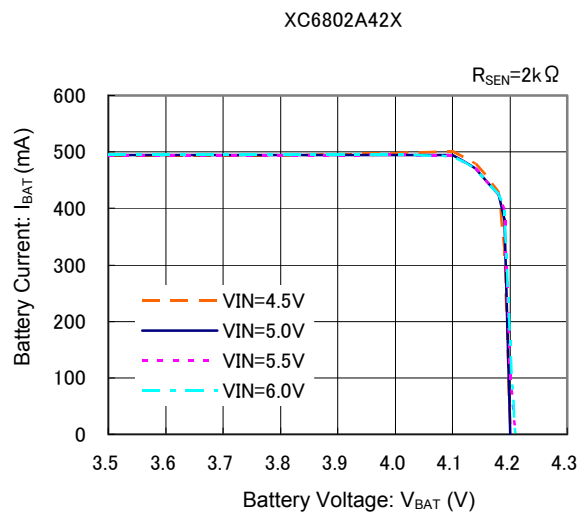
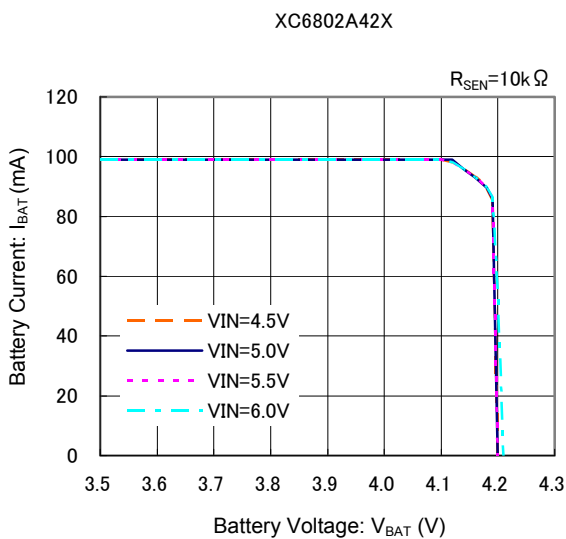
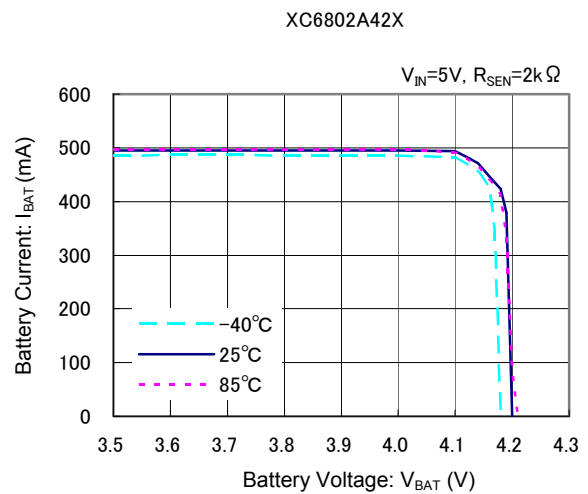
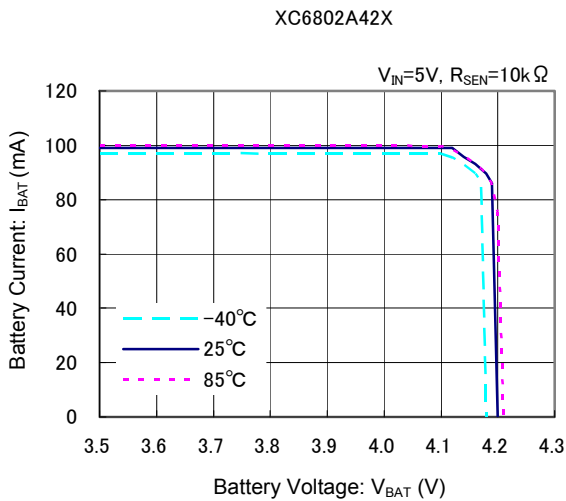

TYPICAL PERFORMANCE CHARACTERISTICS (Continued)

(3) Battery Voltage vs. Battery Current

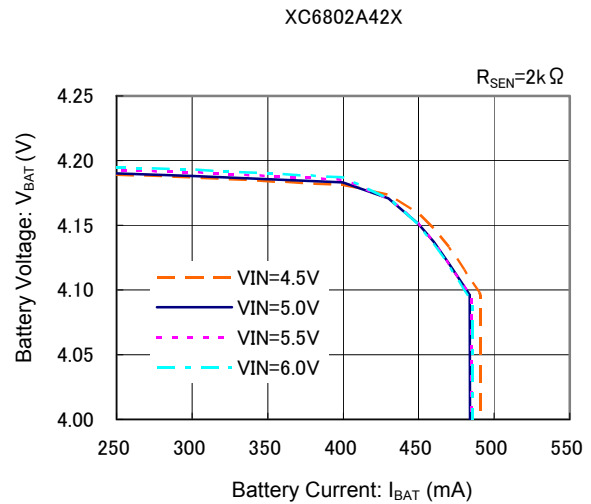
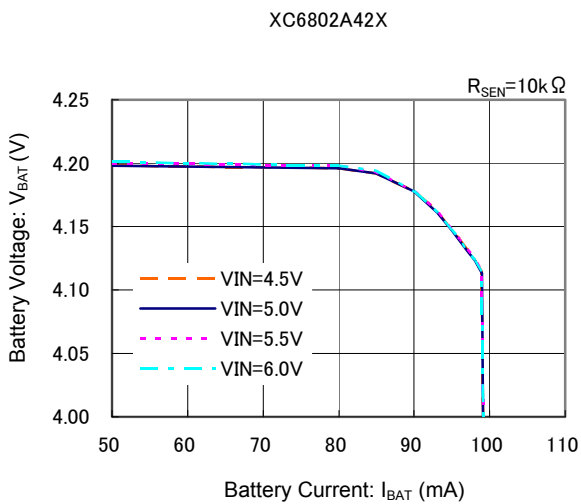
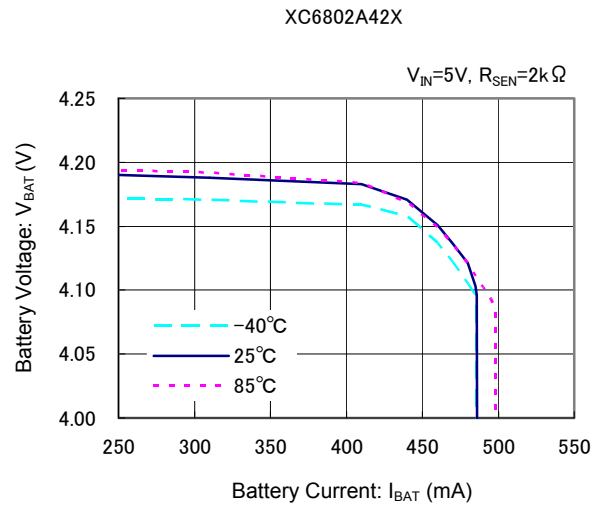
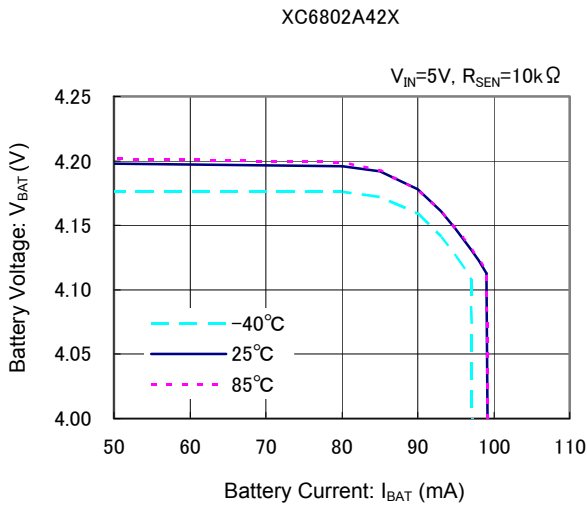

(4) Charge Termination Voltage vs. Ambient Temperature

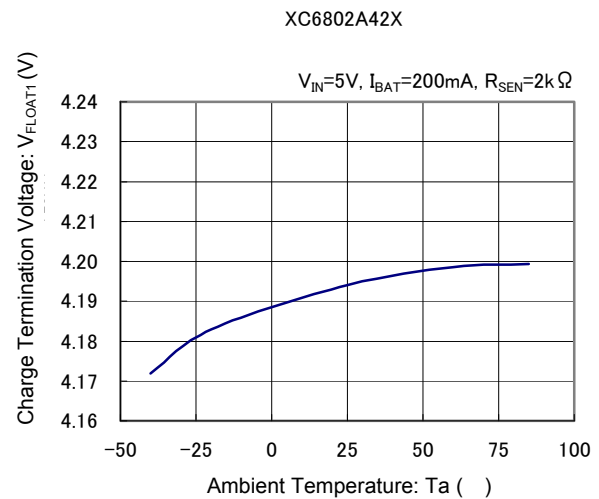
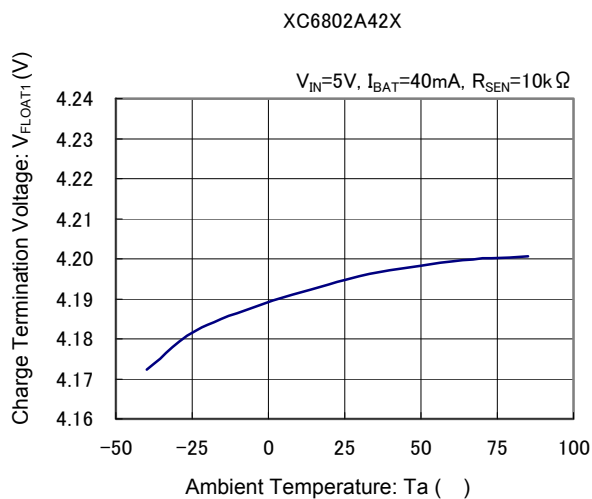

TYPICAL PERFORMANCE CHARACTERISTICS (Continued)

(5) Battery Current vs. Ambient Temperature

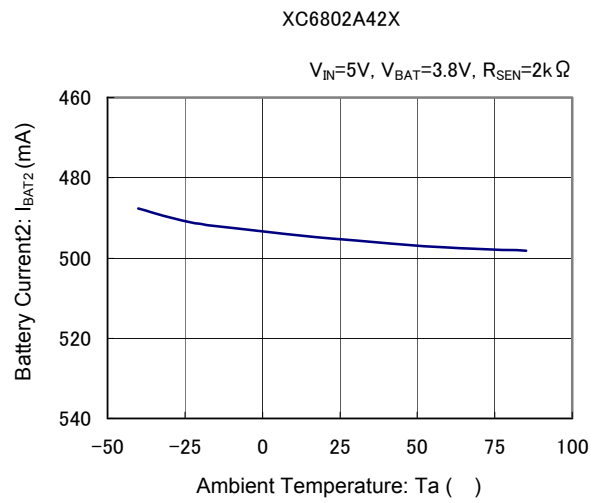
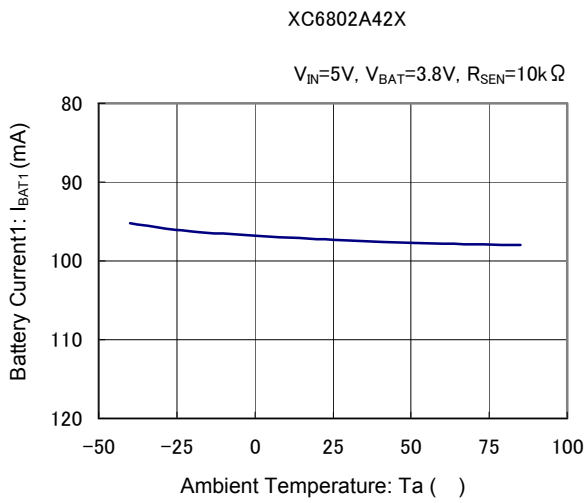

(6) Trickle Charge Current vs. Ambient Temperature

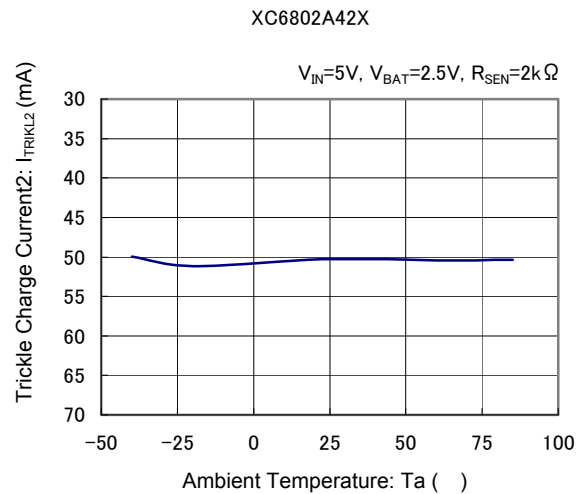
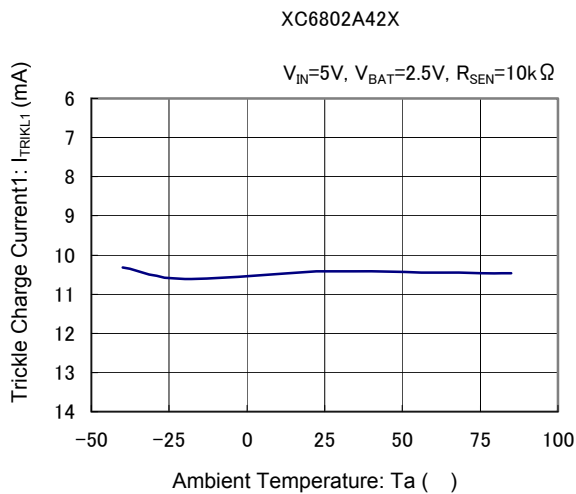

(7) Trickle Voltage vs. Ambient Temperature

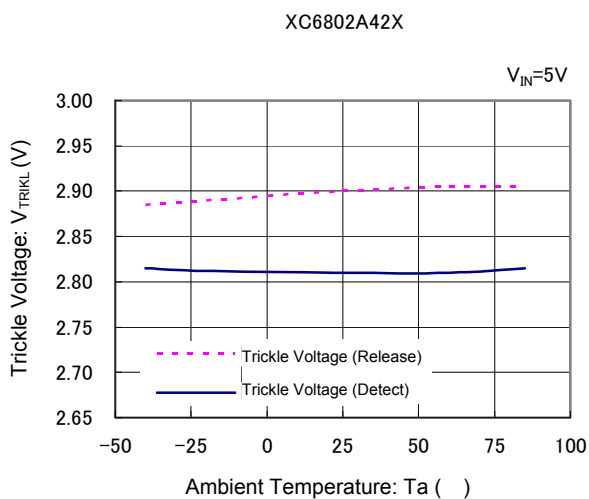

(8) Manual Shutdown Voltage vs. Ambient Temperature

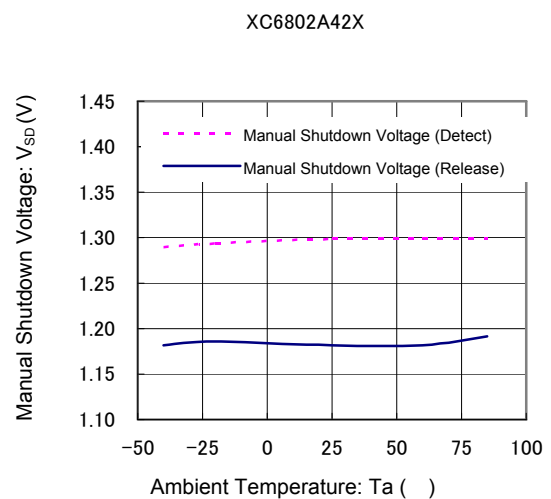

TYPICAL PERFORMANCE CHARACTERISTICS (Continued)

(9) UVLO Voltage vs. Ambient Temperature

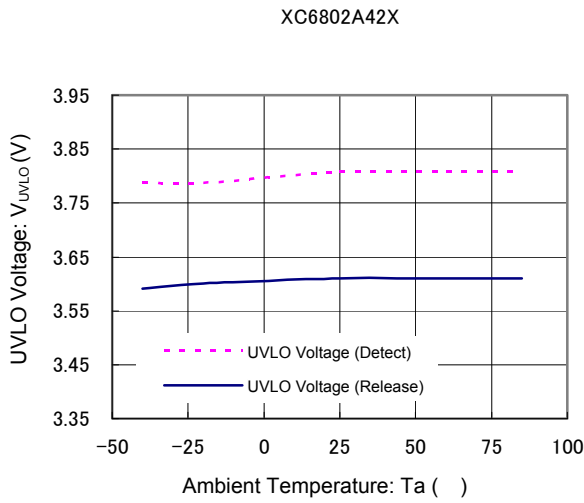

(10) $V_{IN} - V_{BAT}$ Shutdown Voltage vs. Ambient Temperature

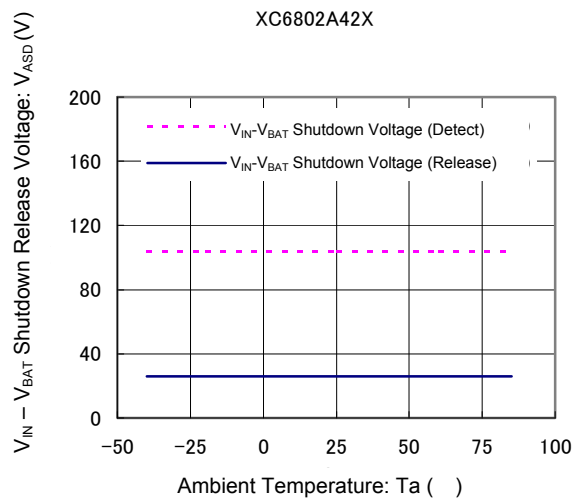

(11) Charge Termination Detect Time vs. Ambient Temperature

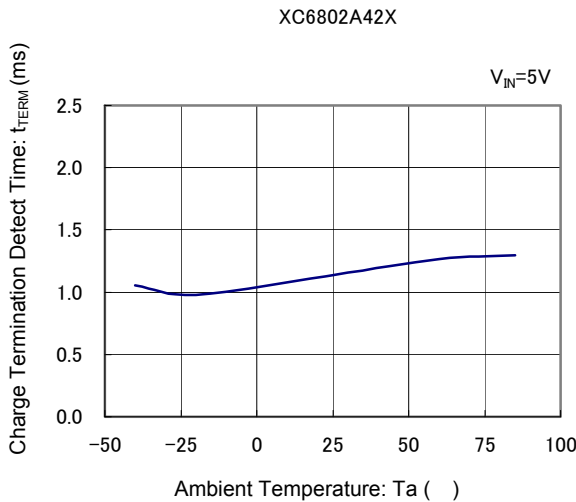

(12) Recharge Time vs. Ambient Temperature

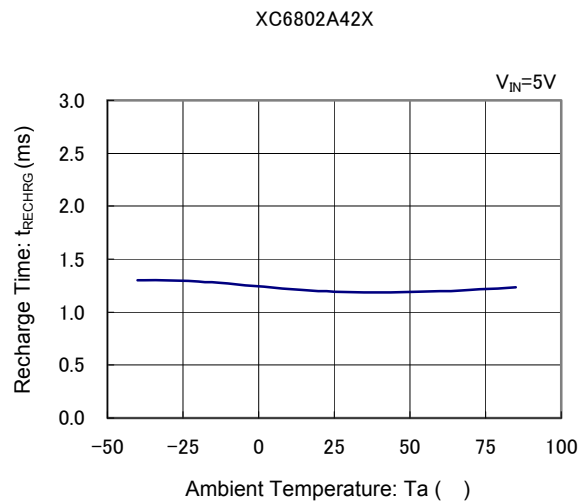

(13) Recharge Threshold Voltage vs. Ambient Temperature

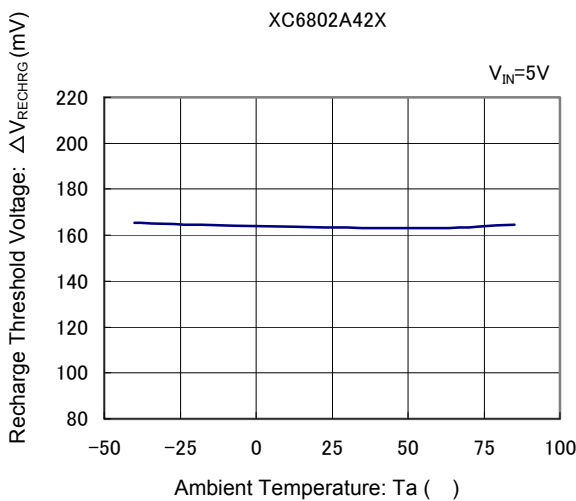

(14) Soft Start Time vs. Ambient Temperature

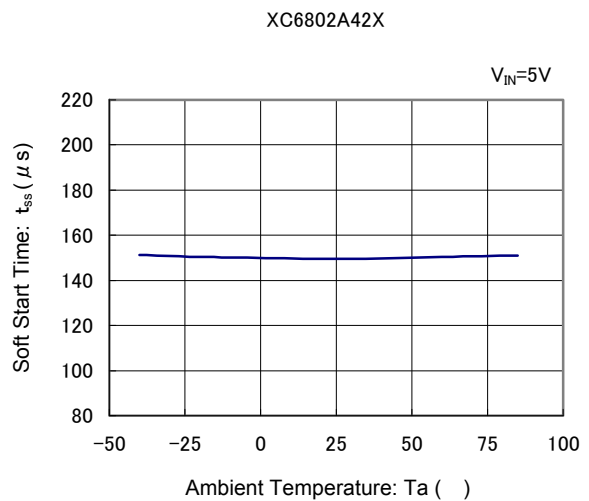

TYPICAL PERFORMANCE CHARACTERISTICS (Continued)

(15) ON Resistance vs. Ambient Temperature

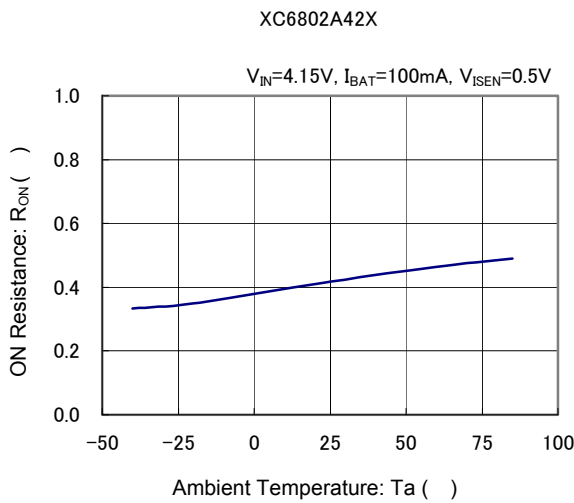

(16) Shutdown Current vs. Ambient Temperature

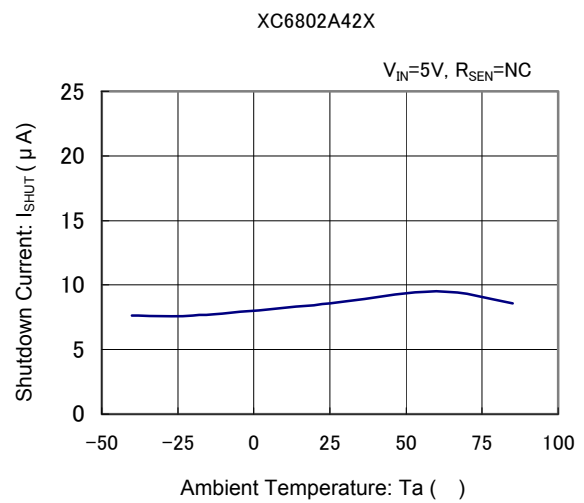

(17) Stand-by Current vs. Ambient Temperature

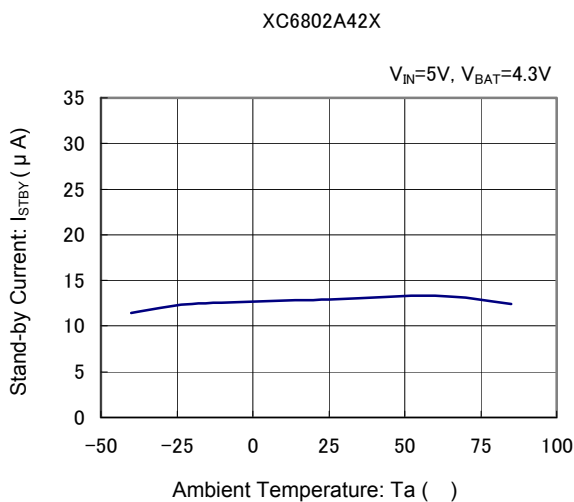

(18) /CHG Weak Pull Down Current vs. /CHG Pin Voltage

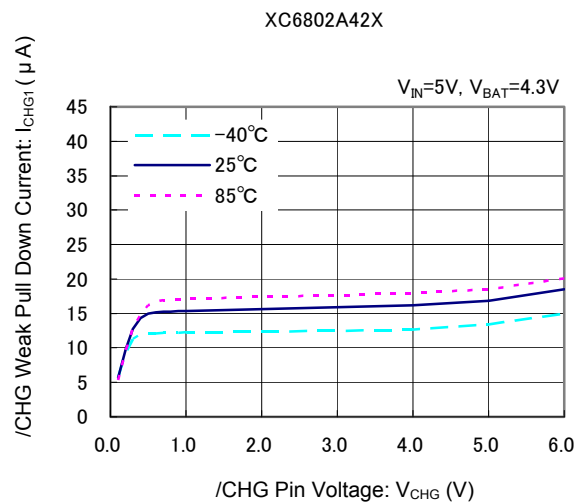

(19) /CHG Strong Pull Down Current vs. /CHG Pin Voltage

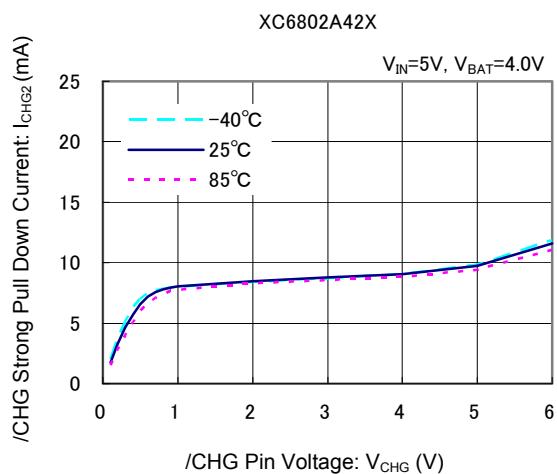

(20) /CHG Pin Output Low Voltage vs. Ambient Temperature

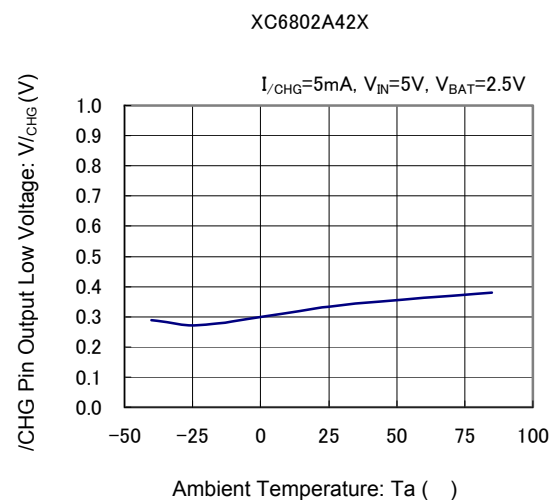

PACKAGING INFORMATION

SOT-25

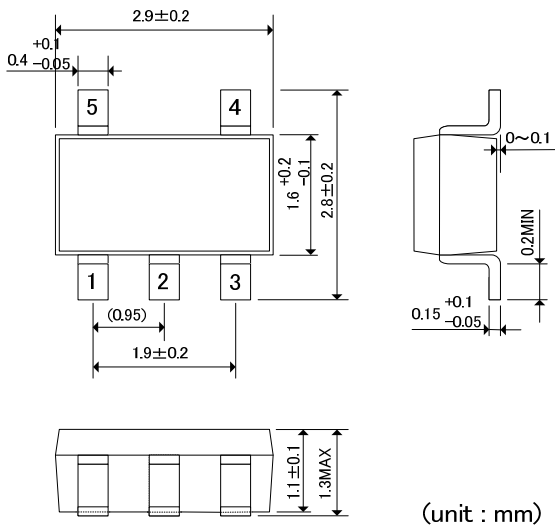

SOT-89-5

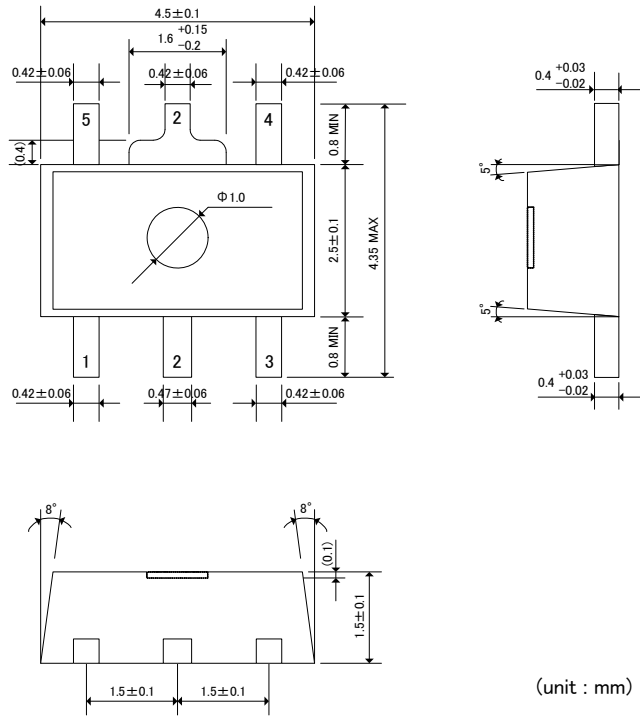

USP-6C

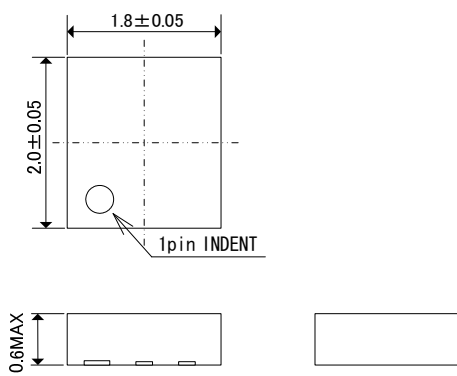

USP-6C Reference Pattern Layout

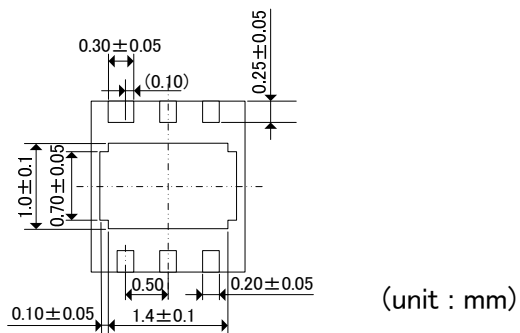
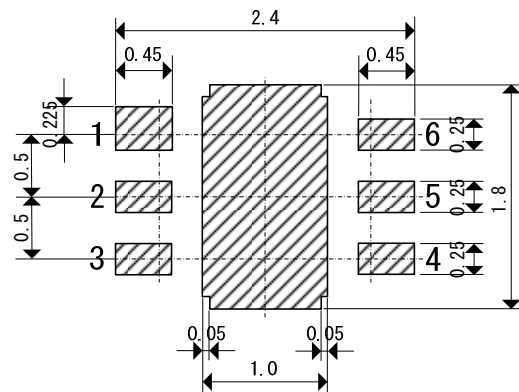

USP-6C Reference Metal Mask Design

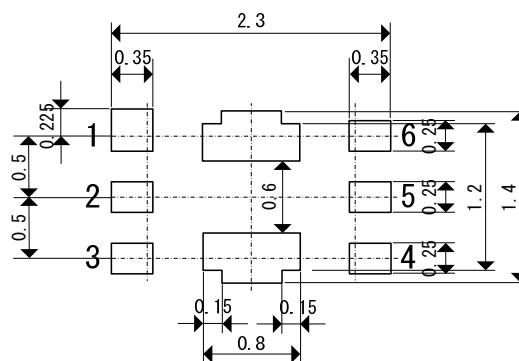

PACKAGING INFORMATION (Continued)

USP-6EL

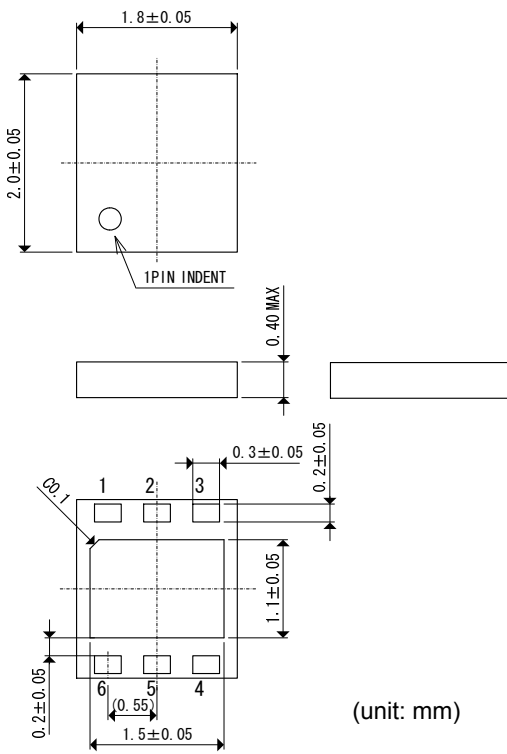

(unit: mm)

<USP-6EL Reference Pattern Layout>

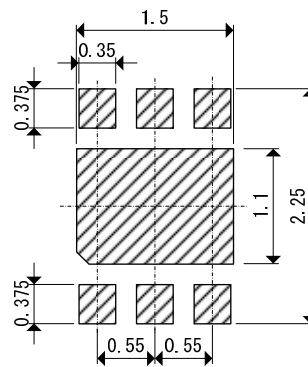

<USP-6EL Reference Metal Mask Design>

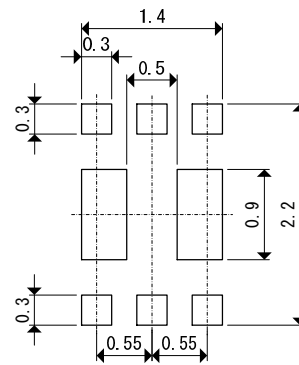

MARKING RULE

USP-6C / USP-6EL

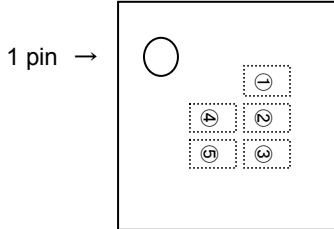

Represents product series

MARK	PRODUCT SERIES
N	XC6802*****-G

Standard product, Represent the 7th digits

MARK	PRODUCT SERIES
A	XC6802A*****-G

SOT-25

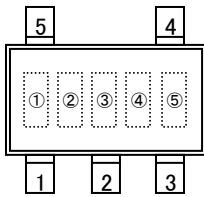

Standard product, Represents the 8th digits

MARK	PRODUCT SERIES
4	XC6802*4****-G

Represents production lot number

01 to 09, 0A to 0Z, 11 to 9Z, A1 to A9, AA to AZ, B1 to ZZ in order.

(G, I, J, O, Q, W excepted)

*No character inversion used.

SOT-89-5

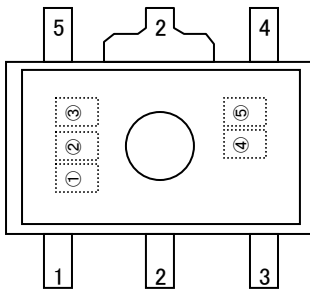

PACKAGING INFORMATION (Continued)

SOT-89-5 Power Dissipation

Power dissipation data for the SOT-89-5 is shown in this page.
The value of power dissipation varies with the mount board conditions.
Please use this data as one of reference data taken in the described condition.

1. Measurement Condition (Reference data)

- Condition: Mount on a board
- Ambient: Natural convection
- Soldering: Lead (Pb) free
- Board: Dimensions 40 x 40 mm (1600 mm² in one side)
Copper (Cu) traces occupy 50% of the board area
In top and back faces
Package heat-sink is tied to the copper traces
- Material: Glass Epoxy (FR-4)
- Thickness: 1.6 mm
- Through-hole: 5 x 0.8 Diameter

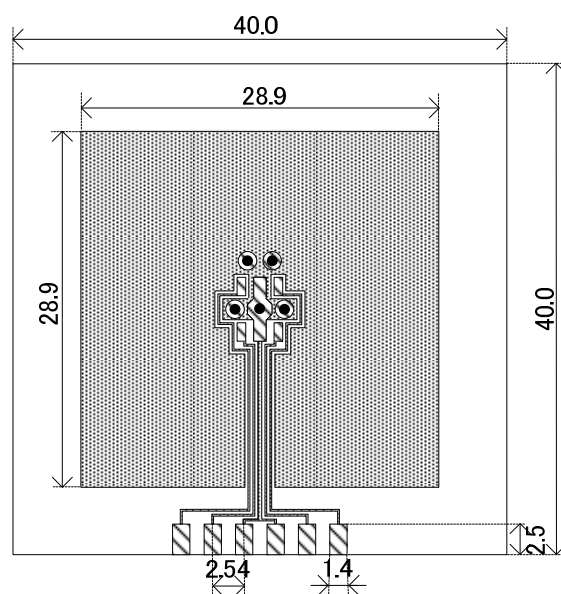

Evaluation Board (Unit: mm)

2. Power Dissipation vs. Ambient Temperature

Board Mount ($T_j \text{ max} = 125$)

Ambient Temperature (°C)	Power Dissipation Pd (mW)	Thermal Resistance (°C/W)
25	1300	76.92
85	520	

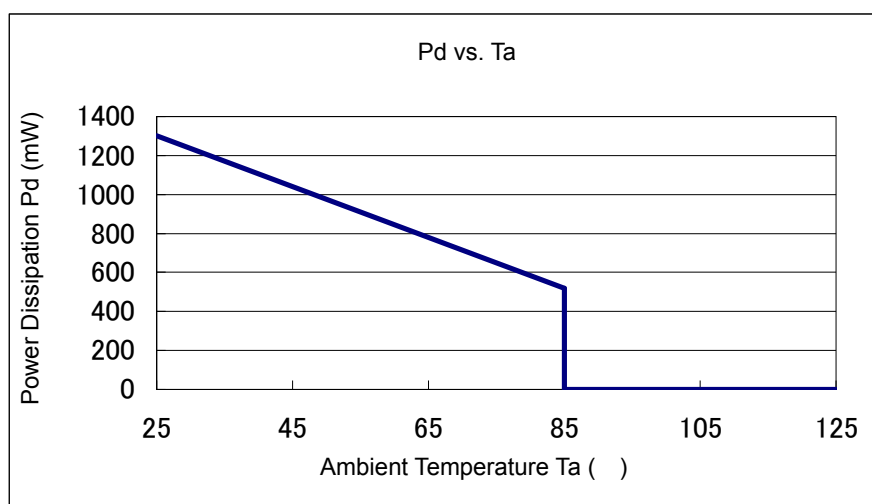

PACKAGING INFORMATION (Continued)

SOT-25 Power Dissipation

Power dissipation data for the SOT-25 is shown in this page.
 The value of power dissipation varies with the mount board conditions.
 Please use this data as one of reference data taken in the described condition.

1. Measurement Condition (Reference data)

- Condition: Mount on a board
- Ambient: Natural convection
- Soldering: Lead (Pb) free
- Board: Dimensions 40 x 40 mm (1600 mm² in one side)
 Copper (Cu) traces occupy 50% of the board area
 In top and back faces
 Package heat-sink is tied to the copper traces
 (Board of SOT-26 is used.)
- Material: Glass Epoxy (FR-4)
- Thickness: 1.6 mm
- Through-hole: 4 x 0.8 Diameter

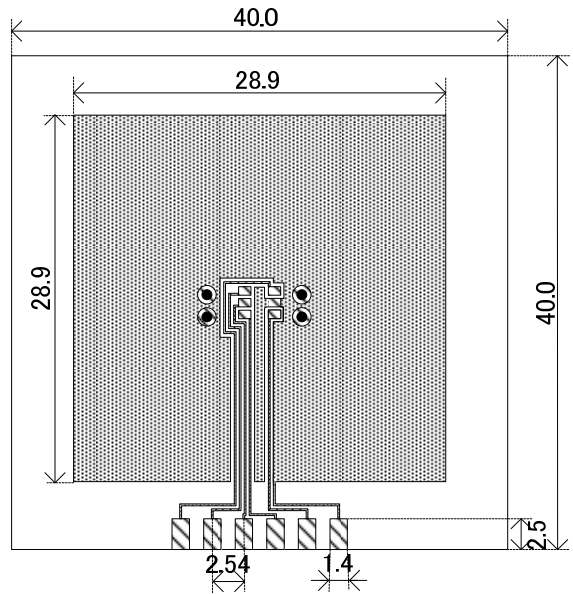

Evaluation Board (Unit: mm)

2. Power Dissipation vs. Ambient Temperature

Board Mount ($T_j \text{ max} = 125 \text{ }^\circ\text{C}$)

Ambient Temperature ($^\circ\text{C}$)	Power Dissipation Pd (mW)	Thermal Resistance ($^\circ\text{C/W}$)
25	600	166.67
85	240	

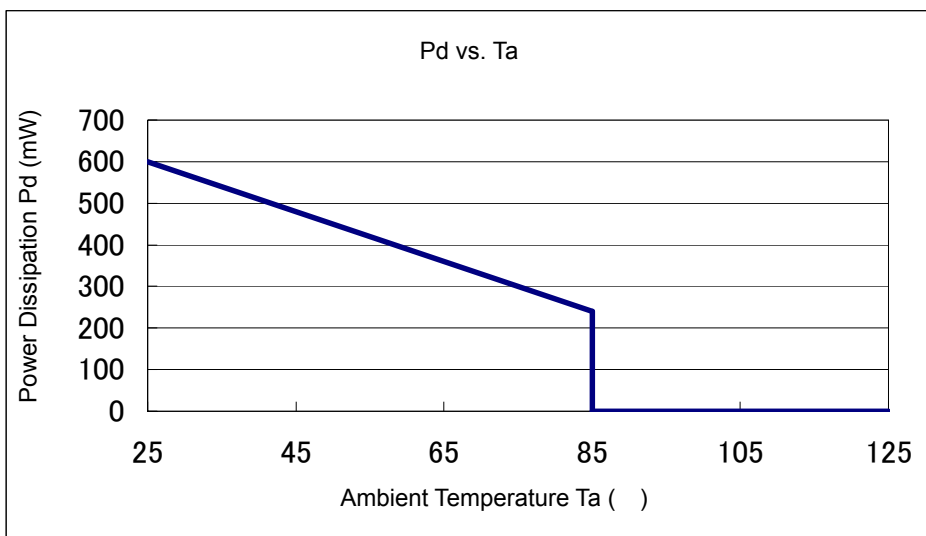

PACKAGING INFORMATION (Continued)

USP-6C Power Dissipation

Power dissipation data for the USP-6C is shown in this page.
The value of power dissipation varies with the mount board conditions.
Please use this data as one of reference data taken in the described condition.

1. Measurement Condition (Reference data)

- Condition: Mount on a board
- Ambient: Natural convection
- Soldering: Lead (Pb) free
- Board: Dimensions 40 x 40 mm (1600 mm² in one side)
Copper (Cu) traces occupy 50% of the board area
In top and back faces
Package heat-sink is tied to the copper traces
- Material: Glass Epoxy (FR-4)
- Thickness: 1.6 mm
- Through-hole: 4 x 0.8 Diameter

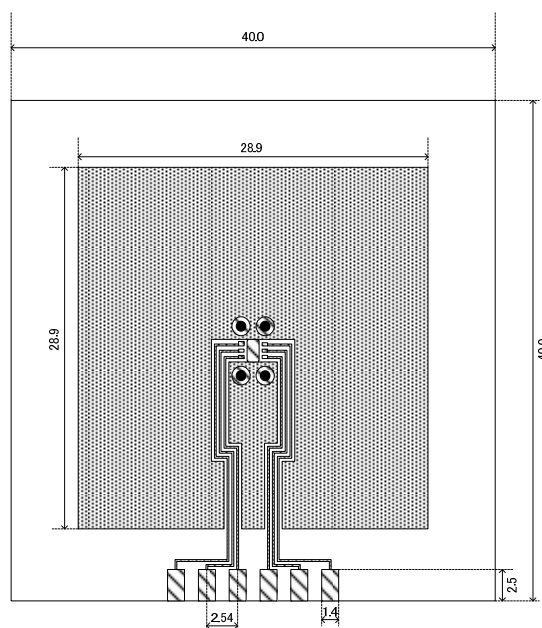

Evaluation Board (Unit: mm)

2. Power Dissipation vs. Ambient Temperature

Board Mount ($T_j \text{ max} = 125$)

Ambient Temperature (°C)	Power Dissipation Pd (mW)	Thermal Resistance (°C/W)
25	1000	100
85	400	

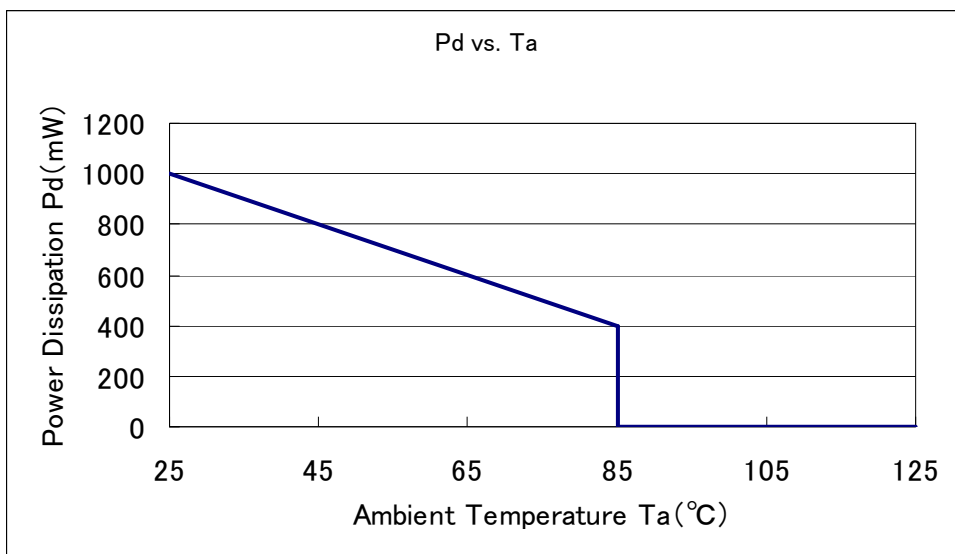

PACKAGING INFORMATION (Continued)

● USP-6EL Power Dissipation

Power dissipation data for the USP-6EL is shown in this page.
 The value of power dissipation varies with the mount board conditions.
 Please use this data as one of reference data taken in the described condition.

1. Measurement Condition (Reference data)

- Condition: Mount on a board
- Ambient: Natural convection
- Soldering: Lead (Pb) free
- Board: Dimensions 40 x 40 mm (1600 mm² in one side)
 Copper (Cu) traces occupy 50% of the board area
 In top and back faces
 Package heat-sink is tied to the copper traces
- Material: Glass Epoxy (FR-4)
- Thickness: 1.6 mm
- Through-hole: 4 x 0.8 Diameter

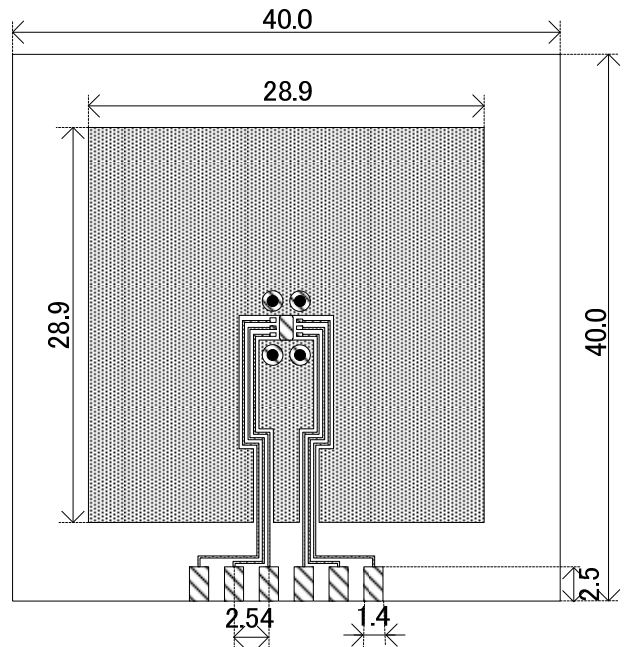

Evaluation Board (Unit: mm)

2. Power Dissipation vs. Ambient Temperature

Board Mount ($T_j \text{ max} = 125$)

Ambient Temperature (°C)	Power Dissipation Pd (mW)	Thermal Resistance (°C/W)
25	1000	100.00
85	400	

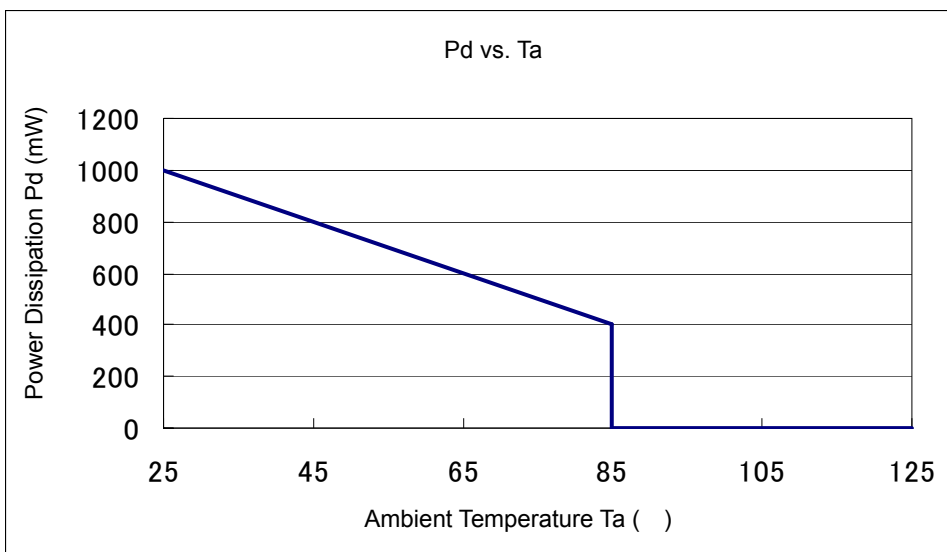

1. The products and product specifications contained herein are subject to change without notice to improve performance characteristics. Consult us, or our representatives before use, to confirm that the information in this datasheet is up to date.
2. We assume no responsibility for any infringement of patents, patent rights, or other rights arising from the use of any information and circuitry in this datasheet.
3. Please ensure suitable shipping controls (including fail-safe designs and aging protection) are in force for equipment employing products listed in this datasheet.
4. The products in this datasheet are not developed, designed, or approved for use with such equipment whose failure or malfunction can be reasonably expected to directly endanger the life of, or cause significant injury to, the user.
(e.g. Atomic energy; aerospace; transport; combustion and associated safety equipment thereof.)
5. Please use the products listed in this datasheet within the specified ranges.
Should you wish to use the products under conditions exceeding the specifications, please consult us or our representatives.
6. We assume no responsibility for damage or loss due to abnormal use.
7. All rights reserved. No part of this datasheet may be copied or reproduced without the prior permission of TOREX SEMICONDUCTOR LTD.

TOREX SEMICONDUCTOR LTD.