

1.5A Positive Voltage Regulator

GENERAL DESCRIPTION

The XB1086 is a series of low dropout positive voltage regulators with a high output current capability of 1.5A.

Stable output can be maintained by using $10\ \mu\text{F}$ (C_{IN}) and $22\ \mu\text{F}$ (C_{L}) of tantalum capacitors.

The XB1086P series is available in the fixed voltage types of 1.5V, 1.8V, 2.5V, 3.3V, and 5.0V. The XB1086K is also available as a voltage adjustable type which can set the output voltage with only two external resistors. With an over current and thermal protection circuit built-in, the IC is disabled for protection when an output current reaches limit current or junction temperature increases up to limit temperature.

The XB1086 series is available in TO-252 package.

APPLICATIONS

- High efficiency linear regulators
- Battery chargers
- DVD drives
- Set top boxes
- Various battery drive equipment

FEATURES

- Maximum Output Current** : More than 1.5A (within Pd)
- Maximum Operating Voltage** : 15V
- Output Voltage** : 1.5V, 1.8V, 2.5V, 3.3V, 5.0V (XB1086P), Externally Set (XB1086K / Reference Voltage 1.25V (TYP.))
- Output Voltage Accuracy** : $\pm 1\%$ ($T_j = 25^\circ\text{C}$)
- Dropout Voltage** : 1.3V @ $I_{\text{OUT}} = 1.5\text{A}$ (TYP.)
- Line Regulation** : 0.015% (TYP.) <ADJ>
- Load Regulation** : 0.1% (TYP.) <ADJ>
- Reference Voltage Pin Current**: Less than $120\ \mu\text{A}$ <ADJ>
- Overcurrent Protection Circuit Built-In**
- Thermal Protection Circuit Built-In**
- Package** : TO-252
- Environmentally Friendly** : EU RoHS Compliant

TYPICAL APPLICATION CIRCUITS

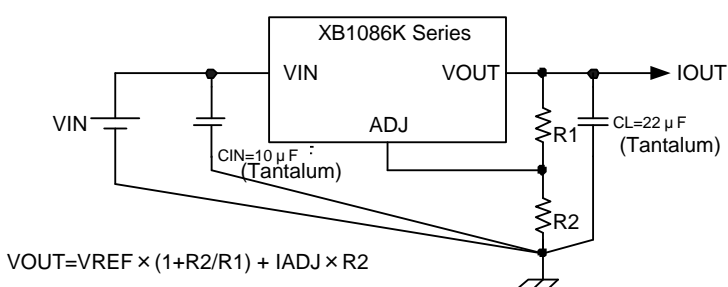
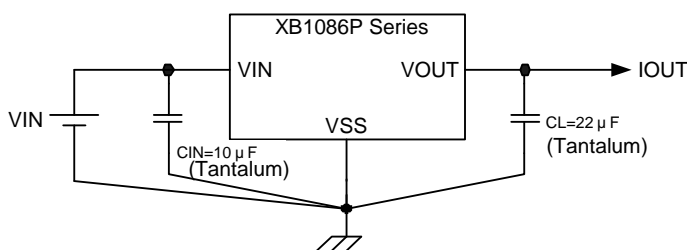

TYPICAL PERFORMANCE CHARACTERISTICS

Output Voltage vs. Output Current

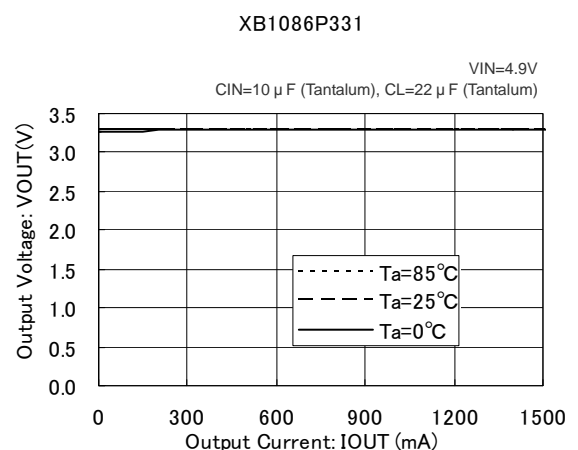

PIN CONFIGURATION

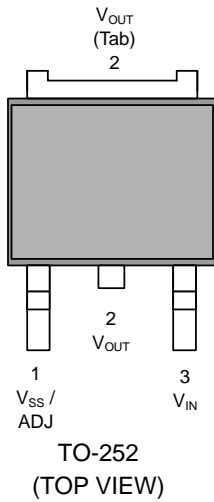

PIN ASSIGNMENT

PIN NUMBER	PIN NAME	FUNCTIONS
TO-252		
1	V_{SS} / ADJ	Ground / Reference Voltage
2	V_{OUT}	Output
3	V_{IN}	Input

PRODUCT CLASSIFICATION

Ordering Information

XB1086 _____

DESIGNATOR	DESCRIPTION	SYMBOL	DESCRIPTION
	Type of Regulators	P	Fixed V_{OUT}
		K	Adjustable (Externally Set)
	Output Voltage and Output Voltage Accuracy	151	$V_{OUT}=1.5V (\pm 1\%)$
		181	$V_{OUT}=1.8V (\pm 1\%)$
		251	$V_{OUT}=2.5V (\pm 1\%)$
		331	$V_{OUT}=3.3V (\pm 1\%)$
		501	$V_{OUT}=5.1V (\pm 1\%)$
		12B	$V_{REF}=1.25V (\pm 1\%)$
	Packages Taping Type ^(*)	JR	TO-252

^(*) The device orientation is fixed in its embossed tape pocket. For reverse orientation, please contact your local Torex sales office or representative. (Standard orientation: R, Reverse orientation: L)

BLOCK DIAGRAM

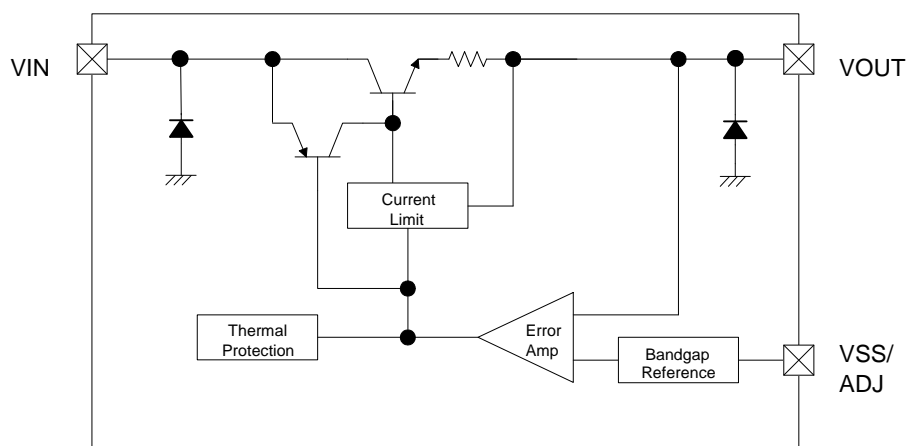

*Diodes inside the circuit are ESD protection diodes.

ABSOLUTE MAXIMUM RATINGS

PARAMETER	SYMBOL	RATINGS	UNIT
Input Voltage	V_{IN}	18	V
Power Dissipation	P_d	1300 ^(*2)	mW
Operating Junction Temperature	T_j	125	
Storage Temperature Range	T_{stg}	- 55 ~ 125	

Note:

*1: Stresses greater than those listed under the above ratings may cause permanent damage to the device.

*2: The rating of the power dissipation is determined when mounted on the PCB.

ELECTRICAL CHARACTERISTICS

XB1086PxxxJ

T_j = 25 unless otherwise specified

PARAMETER	SYMBOL	CONDITIONS	MIN.	TYP.	MAX.	UNIT	CIRCUIT	
Output Voltage	V _{OUT} (1.5V)	V _{IN} =3.5V, I _{OUT} =10mA		1.485	1.5	1.515	V	
			O.T. (*1)	1.47	-	1.53		
	V _{OUT} (1.8V)	V _{IN} =3.8V, I _{OUT} =10mA		1.782	1.8	1.818	V	
			O.T. (*1)	1.746	-	1.854		
	V _{OUT} (2.5V)	V _{IN} =4.5V, I _{OUT} =10mA		2.475	2.500	2.525	V	
O.T. (*1)			2.45	-	2.55			
V _{OUT} (3.3V)	V _{IN} =5.0V, I _{OUT} =10mA		3.267	3.300	3.333	V		
		O.T. (*1)	3.235	-	3.366			
V _{OUT} (5.0V)	V _{IN} =7.0V, I _{OUT} =10mA		4.95	5	5.05	V		
		O.T. (*1)	4.9	-	5.1			
Line Regulation	V _{OUT1} (1.5V)	1.5V V _{IN} -V _{OUT} 10V I _{OUT} =10mA		-	0.3	6	mV	
			O.T. (*1)	-	0.6	6		
	V _{OUT1} (1.8V)	1.5V V _{IN} -V _{OUT} 10V I _{OUT} =10mA		-	0.3	6	mV	
			O.T. (*1)	-	0.6	6		
	V _{OUT1} (2.5V)	1.5V V _{IN} -V _{OUT} 10V I _{OUT} =10mA		-	0.3	6	mV	
O.T. (*1)			-	0.6	6			
V _{OUT1} (3.3V)	1.5V V _{IN} -V _{OUT} 10V I _{OUT} =10mA		-	0.5	10	mV		
		O.T. (*1)	-	1	10			
V _{OUT1} (5.0V)	1.5V V _{IN} -V _{OUT} 10V I _{OUT} =10mA		-	0.5	10	mV		
		O.T. (*1)	-	1	10			
Load Regulation	V _{OUT2} (1.5V)	V _{IN} -V _{OUT} =2.0V 10mA I _{OUT} 1.5A		-	3	12	mV	
			O.T. (*1)	-	6	20		
	V _{OUT2} (1.8V)	V _{IN} -V _{OUT} =2.0V 10mA I _{OUT} 1.5A		-	3	12	mV	
			O.T. (*1)	-	6	20		
	V _{OUT2} (2.5V)	V _{IN} -V _{OUT} =2.0V 10mA I _{OUT} 1.5A		-	3	12	mV	
O.T. (*1)			-	6	20			
V _{OUT2} (3.3V)	V _{IN} -V _{OUT} =2.0V 10mA I _{OUT} 1.5A		-	3	15	mV		
		O.T. (*1)	-	7	20			
V _{OUT2} (5.0V)	V _{IN} -V _{OUT} =2.0V 10mA I _{OUT} 1.5A		-	5	20	mV		
		O.T. (*1)	-	10	35			
Dropout Voltage	V _{dif}	V _{OUT} =1%, I _{OUT} =1.5A	-	1.3	1.5	V		
Current Limit	I _{LIM}	V _{IN} -V _{OUT} =2.0V	1.5	2.3	-	A		
Supply Current	I _{DD}	V _{IN} =V _{OUT} +1.3V	O.T. (*1)	5	10	mA		
Temperature Stability I _{OUT} =10mA	T _s O.T. (*1)	V _{IN} -V _{OUT} =1.5V I _{OUT} =10mA	O.T. (*1)	-	0.5	-	%	-

Note:

*1: O.T. denotes the specifications which apply over the range of operating junction temperature (0 ≤ T_j ≤ 125°C).

Please be sure that the power consumption does not exceed the power dissipation rating, 1300mW. If the power consumption exceeds the power dissipation rating and the operating junction temperature rises more than the rating, 125°C, the IC enters thermal shutdown state.

ELECTRICAL CHARACTERISTICS (Continued)

XB1086K12BJ

 $T_j = 25$ unless otherwise specified

PARAMETER	SYMBOL	CONDITIONS	MIN.	TYP.	MAX.	UNIT	CIRCUIT	
Reference Voltage	V _{REF}	V _{IN} -V _{OUT} =2.0V I _{OUT} =10mA	1.238	1.250	1.262	V		
		O.T. (*1)	1.225	-	1.270			
Line Regulation	V _{OUT1}	1.5V V _{IN} -V _{OUT} 10V I _{OUT} =10mA	-	0.015	0.2	%		
		O.T. (*1)		0.035	0.2			
Load Regulation	V _{OUT2}	V _{IN} -V _{OUT} =2.0V 10mA I _{OUT} 1.5A	-	0.1	0.3	%		
		O.T. (*1)		0.2	0.4			
Dropout Voltage	V _{dif}	V _{OUT} =1%, I _{OUT} =1.5A	-	1.3	1.5	V		
Current Limit	I _{LIM}	V _{IN} -V _{OUT} =2.0V	1.5	2.3	-	A		
Temperature Stability	T _S	V _{IN} -V _{OUT} =1.5V I _{OUT} =10mA	O.T. (*1)	-	0.5	-	%	-
Minimum Output Current	I _{OUTmin}	1.4V V _{IN} -V _{OUT} 10V	O.T. (*1)	-	2	5	mA	
Adjust Voltage Pin Current	I _{ADJ}	V _{IN} =V _{OUT} +1.5V I _{OUT} =10mA	O.T. (*1)	-	60	120	μA	

Note:

 *1: O.T. denotes the specifications which apply over the range of operating junction temperature (0 T_j 125°C).

Please be sure that the power consumption does not exceed the power dissipation rating, 1300mW. If the power consumption exceeds the power dissipation rating and the operating junction temperature rises more than the rating, 125°C, the IC enters thermal shutdown state.

TEST CIRCUITS

XB1086PxxxJ

Circuit

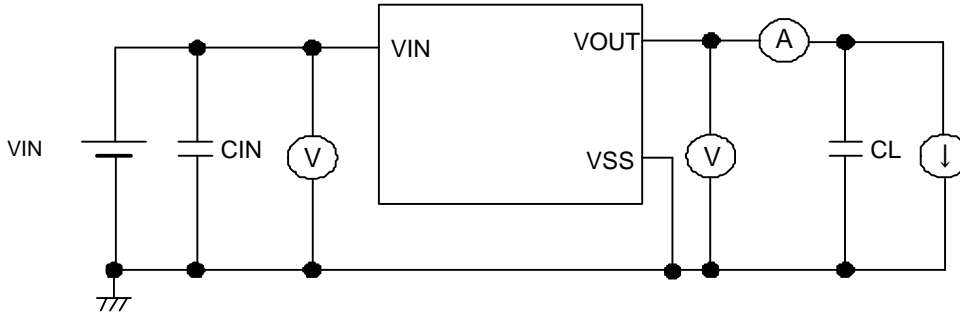

* $C_{IN}=10\ \mu\text{F}$ (Tantalum), $C_L=22\ \mu\text{F}$ (Tantalum)

Circuit

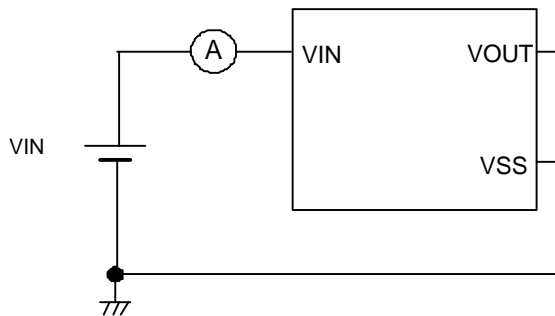

XB1086K12BJ

Circuit

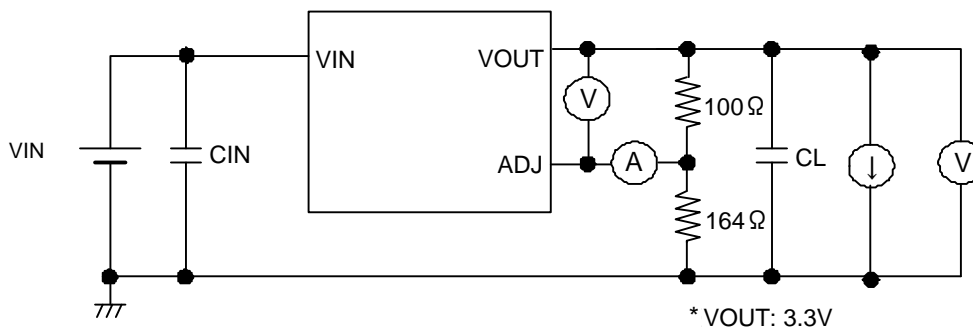

* $V_{OUT}: 3.3\text{V}$

* $C_{IN}=10\ \mu\text{F}$ (Tantalum), $C_L=22\ \mu\text{F}$ (Tantalum)

TYPICAL PERFORMANCE CHARACTERISTICS

(1) Output Voltage vs. Output Current

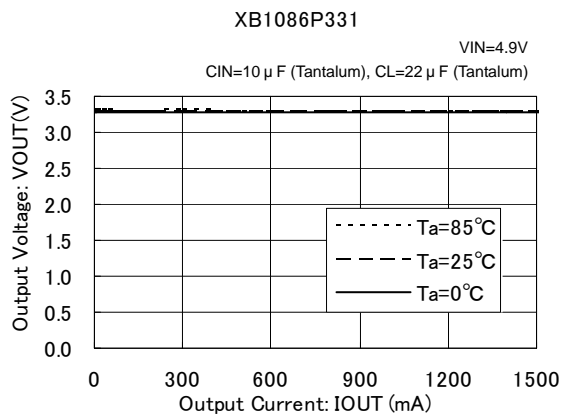

(2) Output Voltage vs. Input Voltage

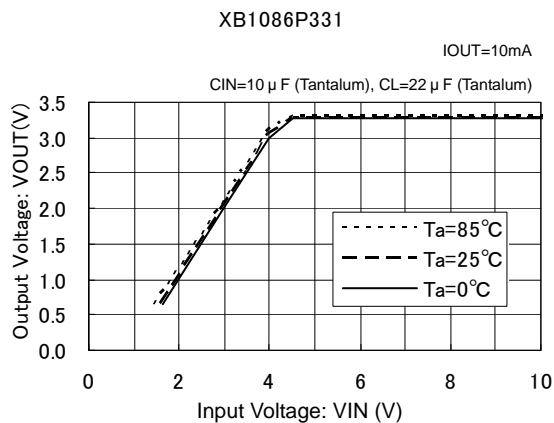

(3) Dropout Voltage vs. Output Current

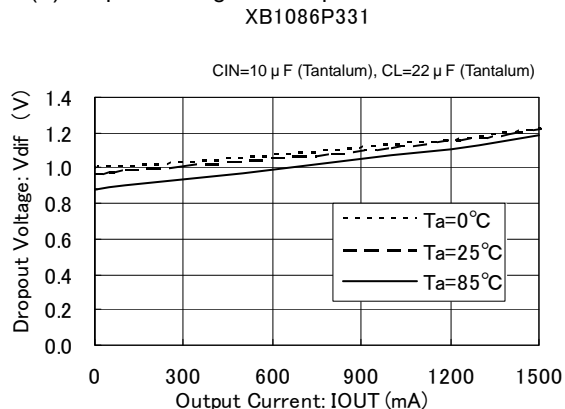

(4) Supply Current vs. Input Voltage

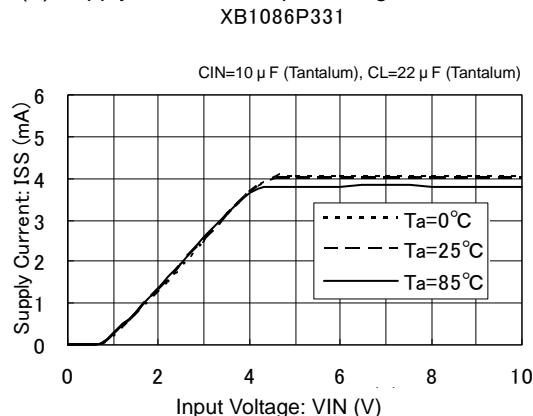

(5) Reference Voltage vs. Ambient Temperature

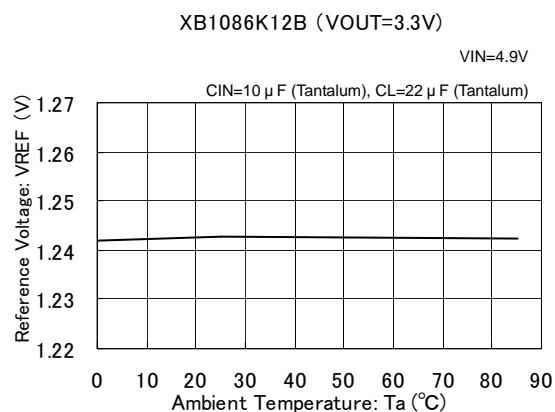

(6) Adjust Pin Current vs. Ambient Temperature

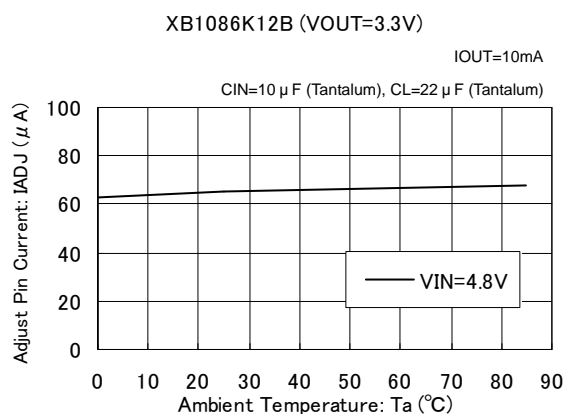

TYPICAL PERFORMANCE CHARACTERISTICS (Continued)

(7) Load Transient Response

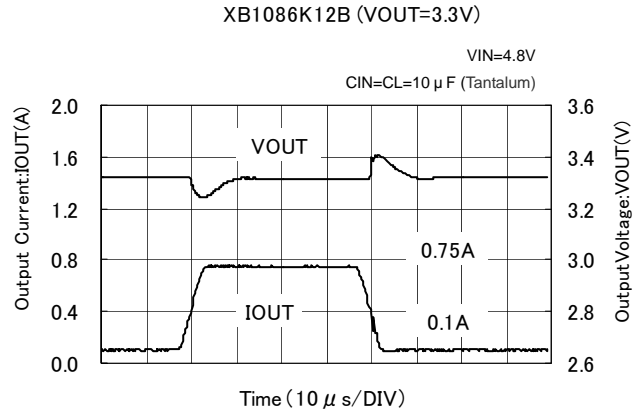
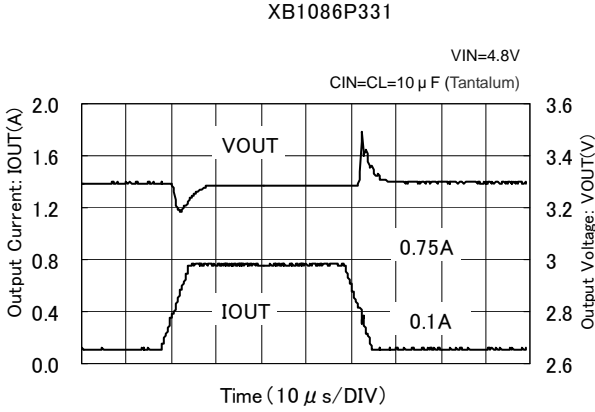

(8) Input Transient Response

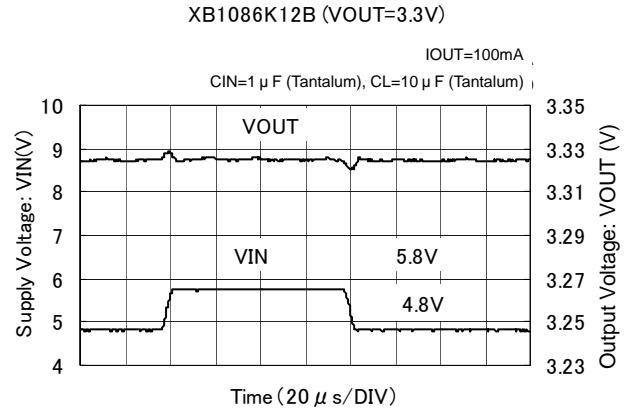
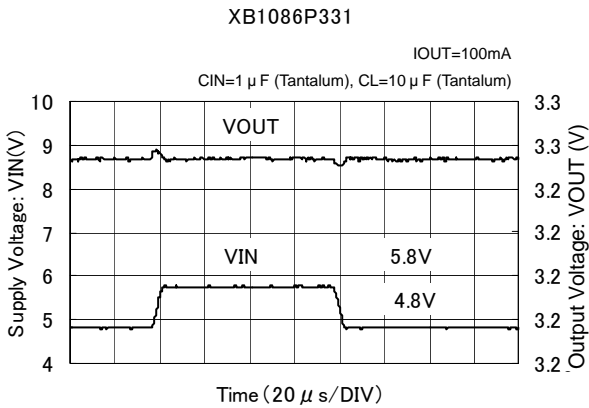

(9) Ripple Rejection Rate

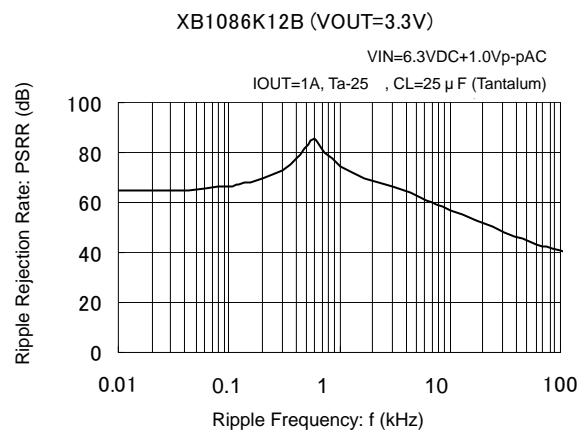
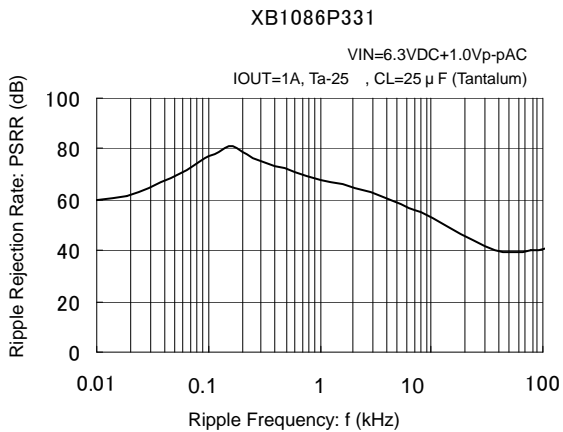

PACKAGING INFORMATION

TO-252

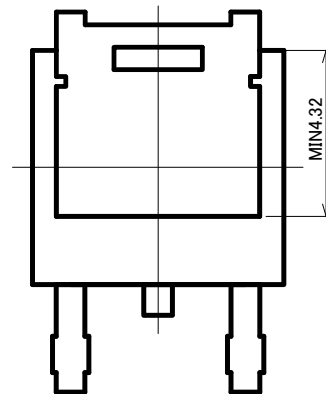
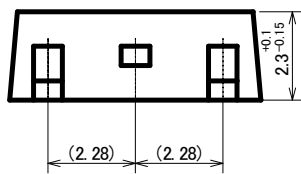
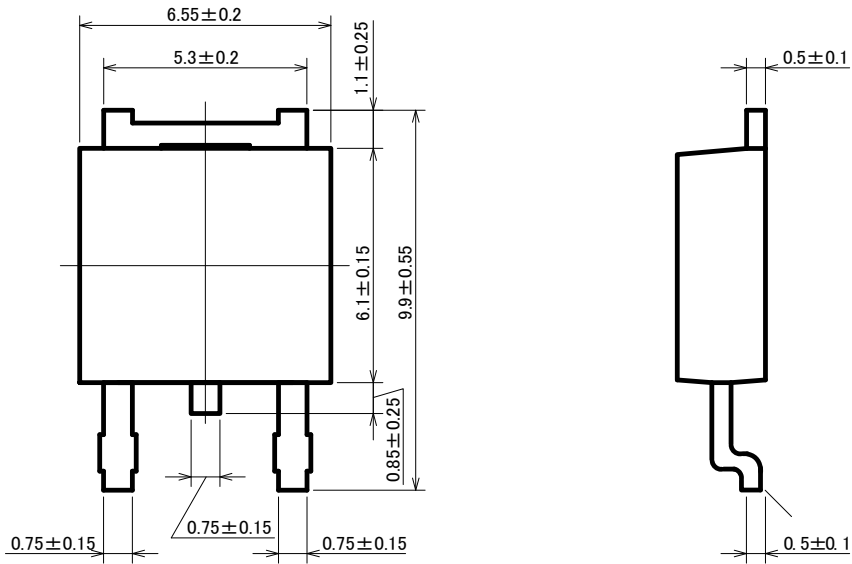

UNIT : mm

MARKING RULE

TO-252

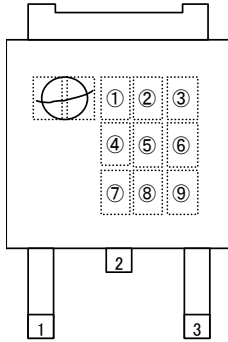

TO-252
(TOP VIEW)

TO252

Represents product series

MARK		PRODUCT SERIES
①	②	
8	5	XB1086****J*

Represent the type of regulator

MARK		PRODUCT SERIES
P		XB1086P***J*
K		XB1086K***J*

Represents output voltage

MARK		OUTPUT VOTLAGE PRODUCT SERIES	
④	⑤		
1	5	1.5V	XB1086P151J*
1	8	1.8V	XB1086P181J*
2	5	2.5V	XB1086P251J*
3	3	3.3V	XB1086P331J*
5	0	5.0V	XB1086P501J*
1	2	ADJ	XB1086K12BJ*

Represents output voltage accuracy and output type

MARK	OUTPUT VOLTAGE ACCURACY (OUTPUT TYPE)	PRODUCT SERIES
1	1%	XB1086P**1J*
B	ADJ	XB1086K12BJ*

Represents the last digit of production year

ex.)

MARK	PRODUCTION YEAR
7	2007
8	2008

Represents production lot number

0 to 9, A to Z repeated.

(G, I, J, O, Q, W excepted. '0' of the first digit does not mark.)

*No character inversion used.

ex.)

MARK		PRODUCTION LOT NUMBER
⑧	⑨	
Blank	3	03
1	A	1A

1. The products and product specifications contained herein are subject to change without notice to improve performance characteristics. Consult us, or our representatives before use, to confirm that the information in this datasheet is up to date.
2. We assume no responsibility for any infringement of patents, patent rights, or other rights arising from the use of any information and circuitry in this datasheet.
3. Please ensure suitable shipping controls (including fail-safe designs and aging protection) are in force for equipment employing products listed in this datasheet.
4. The products in this datasheet are not developed, designed, or approved for use with such equipment whose failure or malfunction can be reasonably expected to directly endanger the life of, or cause significant injury to, the user.
(e.g. Atomic energy; aerospace; transport; combustion and associated safety equipment thereof.)
5. Please use the products listed in this datasheet within the specified ranges.
Should you wish to use the products under conditions exceeding the specifications, please consult us or our representatives.
6. We assume no responsibility for damage or loss due to abnormal use.
7. All rights reserved. No part of this datasheet may be copied or reproduced without the prior permission of TOREX SEMICONDUCTOR LTD.

TOREX SEMICONDUCTOR LTD.