

High Current, High Speed LDO Regulators, Voltage Detector Function

■ GENERAL DESCRIPTION

The XC6403/04 series are highly precise, low noise, high current, positive voltage low dropout regulators with built-in voltage detector. They are fabricated using Torex's CMOS process. Performance features of the series includes high ripple rejection and low dropout voltage, and the series features a voltage reference, an error amplifier, a current limiter and a phase compensation circuit plus a driver transistor.

Detect voltage is selectable in 100mV increments within the range of 0.9V to 5.6V and the LDO output voltage is selectable within a range of 0.9V to 5.6V (XC6403) 0.9V to 5.1V (XC6404), also in 100mV increments. The series is also compatible with low ESR ceramic capacitors which give added output stability. This stability can be maintained even during load fluctuations due to the excellent transient response of the series. The current limiter's foldback circuit also operates as a short circuit protection for the output current limiter and the output pin. The series provides options to the user to select from a variety of circuit features, such as detector monitoring, detector output logic, CE and EN pin input logic, internal pull-up / down resistance, and power ready. The IC's internal regulator circuit can be placed in stand-by mode via the EN function (XC6403/04 A to C series). The whole IC can be put in to stand-by mode via the CE function with the XC6403/04D series (semi-custom). In the stand-by mode, power consumption is greatly reduced. The XC6403/04A and B series features the toggle operation function. The regulator output can be OFF when the XC6403/04B series detects voltage (semi-custom). The XC6403/04E series can monitor another power source by using the VSEN pin (semi-custom). The XC6403/04F series can delay the detector output: the delay time can be controlled by the use of an external capacitor (semi-custom).

■ APPLICATIONS

- CD-ROM, CD-R / RW drive
- DVD drive
- HDD drive
- Cameras, Video recorders
- Portable AV equipment
- Battery powered equipment

■ FEATURES

Maximum Output Current	: More than 300mA (380mA limit) ($1.8 \leq V_{ROUT} \leq 5.3V$) [XC6403] More than 500mA (600mA limit) ($2.5V \leq V_{ROUT} \leq 4.9V$) [XC6404]
Dropout Voltage	: 200mV @ 100mA
Operating Voltage Range	: 2.0V ~ 6.0V
VR Output Voltage	: 0.9V ~ 5.6V [XC6403] 0.9V ~ 5.1V [XC6404]
Detect Voltage	: 0.9V ~ 5.5V ($\pm 2\%$) More than 2.0V (V_{IN} sensing)
VR.VD Temp. Coefficient	: $\pm 100\text{ppm}/^\circ\text{C}$ (TYP.)
Low Power Consumption	: 35 μA (TYP.)
High Ripple Rejection	: 65dB @ 10kHz
Highly Accurate	: $\pm 2\%$
Operating Temperature	: - 40 ~ 85 $^\circ\text{C}$
Low ESR Capacitor Compatible	
Ultra Small Packages	: SOT-25 SOT-89-5 USP-6B

Environmentally Friendly: EU RoHS Compliant, Pb Free

■ TYPICAL APPLICATION CIRCUITS

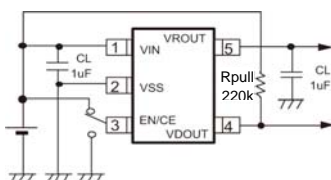

XC6403A ~ D Series

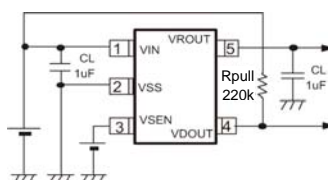

XC6403E Series

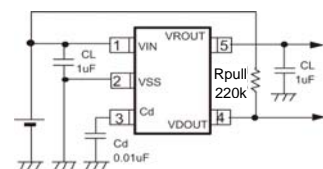

XC6403F Series

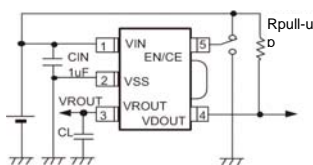

XC6404A ~ D Series

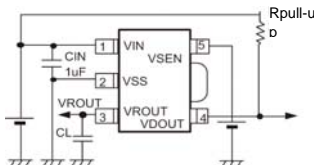

XC6404E Series

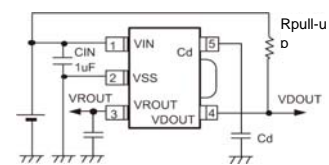

XC6404F Series

XC6403/XC6404 Series

PIN CONFIGURATION

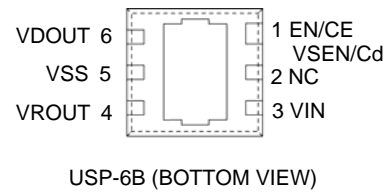
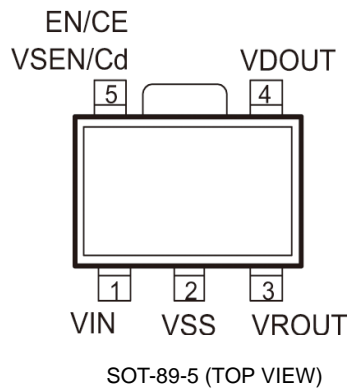
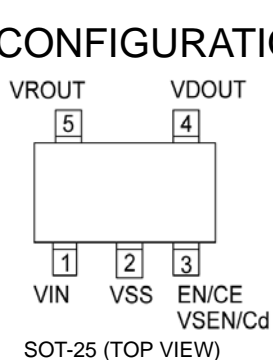

PIN ASSIGNMENT

PIN NUMBER			PIN NAME	FUNCTION
SOT-25	SOT-89-5	USP-6B		
1	1	3	VIN	Power Input
2	2	5	VSS	Ground
3	5	1	EN	VR ON / OFF Control
3	5	1	CE	ON / OFF Control
3	5	1	VSEN	VD Monitoring
3	5	1	Cd	Delay Capacitor Connection
4	4	6	VDOUT	VD Output
5	3	4	VROUT	VR Output
-	-	2	NC	No connection

*The dissipation pad for the USP-6B package should be solder-plated in recommended mount pattern and metal masking so as to enhance mounting strength and heat release. If the pad needs to be connected to other pins, it should be connected to the Vss pin.

PRODUCT CLASSIFICATION

Selection Guide

1. TOGGLE FUNCTION, VD SELF-SATURATION AS OPTION

SERIES	TOGGLE FUNCTION (BUILT-IN)
XC6403/04A	VD with Toggle Function
XC6403/04B	VD with Toggle Function and Self-Saturation
XC6403/04C ~ F	VD with No Toggle Function

2. STAND-BY MODE FUNCTION AS OPTION

SERIES	STAND-BY MODE FUNCTION
XC6403/04A ~ C	VR with Stand-By Mode Function
XC6403/04D	Chip Stand-By Mode Function
XC6403/04E, F	No Stand-By Mode Function

3. CE / EN INPUT LOGIC, INTERNAL PULL-UP/DOWN AS OPTION (*A ~ D Series)

SERIES	CE INPUT LOGIC
XC6403/04 * A ~ D	High Active with Pull Down
XC6403/04 * E ~ K	High Active with No Pull Down
XC6403/04 * L ~ P	Low Active with Pull Up
XC6403/04 * R ~ U	Low Active with No Pull Up

4. VD SENSE AS OPTION (*A ~ D and F Series)

SERIES	VD SENSE PIN
XC6403/04 * A, B, E, F, L, M, R, S, V, X	VIN
XC6403/04 * C, D, H, K, N, P, T, U, Y, Z	VOUT
XC6403/04 E V ~ Z	VSEN

5. VD OUTPUT LOGIC AS OPTION

SERIES	VD OUTPUT LOGIC FUNCTION
XC6403/04A ~ F	Detect L or Detect H

6. VD DELAY FUNCTION AS OPTION

SERIES	DELAY FUNCTION
XC6403/04A ~ E	No Delay
XC6403/04F	Delay Time Adjustable by Connecting Cd

■ PRODUCT CLASSIFICATION (Continued)

● Ordering Information

XC6403/XC6404 ①②③④⑤⑥-⑦^(*)

DESIGNATOR	DESCRIPTION	SYMBOL	DESCRIPTION
①	Operational Function	A	Toggle and EN function (preliminary)
		B	Toggle, EN function, VD signal/VR OFF function (preliminary)
		C	EN function
		D	CE function
		E	VSEN Pin
		F	Cd pin
②	Type of Regulator	-	As in the chart below.
③④	Output Voltage & Detect Voltage	-	Internally set sequential number relating to output voltage and detect voltage (refer to the chart below) VR setting output voltage range: 0.9V~5.6V [XC6403] 0.9V~5.1V [XC6404] Detect voltage setting range: 0.9V ~5.5V 100mV increments are available
⑤⑥-⑦	Packages Taping Type ^(*)	MR	SOT-25
		MR-G	SOT-25
		PR	SOT-89-5
		PR-G	SOT-89-5
		DR	USP-6B
		DR-G	USP-6B

^(*) The "-G" suffix indicates that the products are Halogen and Antimony free as well as being fully RoHS compliant.

⁽²⁾ The device orientation is fixed in its embossed tape pocket. For reverse orientation, please contact your local Torex sales office or representative. (Standard orientation: ⑤R-⑦, Reverse orientation: ⑤L-⑦)

PIN NUMBER : ② Types

②	EN / CE FUNCTION	EN / CE LOGIC	PULL UP/DOWN RESISTANCE	VD SENSE PIN	VD OUTPUT LOGIC	PIN NUMBER①
A	Function	High Active	Pull-down Function	VIN	Detect L	A ~ D Series
B	Function	High Active	Pull-down Function	VIN	Detect H	
C	Function	High Active	Pull-down Function	VROUT	Detect L	
D	Function	High Active	Pull-down Function	VROUT	Detect H	
E	Function	High Active	Nonfunctional	VIN	Detect L	
F	Function	High Active	Nonfunctional	VIN	Detect H	
H	Function	High Active	Nonfunctional	VROUT	Detect L	
K	Function	High Active	Nonfunctional	VROUT	Detect H	
L	Function	Low Active	Pull-up Function	VIN	Detect L	
M	Function	Low Active	Pull-up Function	VIN	Detect H	
N	Function	Low Active	Pull-up Function	VROUT	Detect L	
P	Function	Low Active	Pull-up Function	VROUT	Detect H	
R	Function	Low Active	Nonfunctional	VIN	Detect L	
S	Function	Low Active	Nonfunctional	VIN	Detect H	
T	Function	Low Active	Nonfunctional	VROUT	Detect L	
U	Function	Low Active	Nonfunctional	VROUT	Detect H	
V	Nonfunctional	-	-	VIN / VSEN	Detect L	E & F Series
X	Nonfunctional	-	-	VIN / VSEN	Detect H	
Y	Nonfunctional	-	-	VROUT	Detect L	F Series
Z	Nonfunctional	-	-	VROUT	Detect H	

*The XC6403/04A and XC6403/04B series are under development. For further detail, please ask your sales contacts.

■ PRODUCT CLASSIFICATION (Continued)

● Ordering Information (Continued)

● Pin Number ③, ④ Type (80 ~ 99 : Standard voltage products)

● XC6403 Series

③④	VROUT	VDOUT	③④	VROUT	VDOUT	③④	VROUT	VDOUT	③④	VROUT	VDOUT
01	1.80	2.40	21	3.30	3.10	-	-	-	80	1.80	1.60
02	1.80	2.90	22	2.80	3.10	-	-	-	81	2.80	3.10
03	1.60	1.80	23	-	-	-	-	-	82	1.80	2.00
04	1.80	2.00	24	1.80	2.40	-	-	-	83	2.50	2.80
05	3.00	3.30	25	3.20	2.80	-	-	-	84	2.85	3.20
06	1.80	2.40	26	-	-	-	-	-	85	3.00	3.30
07	1.80	2.90	27	-	-	-	-	-	86	3.50	3.80
08	1.80	2.00	28	-	-	-	-	-	87	3.00	4.20
09	3.00	3.30	29	-	-	-	-	-	88	3.30	4.00
10	2.80	3.10	30	4.00	4.30	-	-	-	89	-	-
11	1.80	1.70	31	2.85	2.70	-	-	-	90	-	-
12	3.00	4.20	32	2.60	2.40	-	-	-	91	-	-
13	1.80	3.00	33	2.70	2.80	-	-	-	92	-	-
14	1.80	3.00	34	2.85	2.55	-	-	-	93	-	-
15	1.80	2.40	35	-	-	-	-	-	94	-	-
16	2.50	2.90	36	-	-	-	-	-	95	-	-
17	1.80	2.30	37	-	-	-	-	-	96	-	-
18	2.80	3.40	38	-	-	-	-	-	97	-	-
19	-	-	39	-	-	-	-	-	98	-	-
20	3.30	3.00	40	-	--	-	-	-	99	-	-

34 : Hysteresis Range 3.0% (TYP.) for an error flag
 For the other voltages, please ask your sales contacts.

● XC6404 Series

③④	VROUT	VDOUT	③④	VROUT	VDOUT	③④	VROUT	VDOUT	③④	VROUT	VDOUT
01	2.70	4.20	21	1.80	3.60	-	-	-	80	1.80	1.60
02	2.70	4.20	22	1.80	4.20	-	-	-	81	2.80	3.10
03	2.50	2.60	23	2.50	2.90	-	-	-	82	1.80	2.00
04	3.30	4.30	24	2.50	3.60	-	-	-	83	2.50	2.80
05	3.30	4.40	25	2.50	4.20	-	-	-	84	2.85	3.20
06	3.30	4.00	26	4.30	4.00	-	-	-	85	3.00	3.30
07	3.30	5.20	27	2.50	3.90	-	-	-	86	3.50	3.80
08	2.80	4.30	28	3.30	3.70	-	-	-	87	3.00	4.20
09	4.30	2.80	29	2.60	3.90	-	-	-	88	3.30	4.00
10	3.30	3.60	30	3.30	4.20	-	-	-	89	-	-
11	2.80	2.10	31	3.30	4.50	-	-	-	90	-	-
12	2.80	2.80	32	2.85	2.60	-	-	-	91	-	-
13	3.30	3.60	33	3.30	2.80	-	-	-	92	-	-
14	3.30	3.60	34	3.40	4.20	-	-	-	93	-	-
15	3.30	3.60	35	-	-	-	-	-	94	-	-
16	3.00	2.70	36	-	-	-	-	-	95	-	-
17	2.80	2.50	37	-	-	-	-	-	96	-	-
18	3.00	2.70	38	-	-	-	-	-	97	-	-
19	2.80	2.50	39	-	-	-	-	-	98	-	-
20	1.80	2.90	40	-	-	-	-	-	99	-	-

For the other voltages, please ask your sales contacts.

■ PRODUCT CLASSIFICATION (Continued)

● Ordering Example (Standard Products)

PRODUCT NAME	PRODUCT DESCRIPTION	VOLTAGE	
		V _{ROUT}	V _{DOUT}
XC6403/04CH80MR	EN Function, High Active, V _{ROUT} Sense, Detect L	1.80	1.60
XC6403/04CE81MR	EN Function, High Active, V _{IN} Sense, Detect L	2.80	3.10
XC6403/04DE82MR	CE Function, High Active, V _{IN} Sense, Detect L	1.80	2.00
XC6403/04DE83MR	CE Function, High Active, V _{IN} Sense, Detect L	2.50	2.80
XC6403/04DE84MR	CE Function, High Active, V _{IN} Sense, Detect L	2.85	3.20
XC6403/04DE85MR	CE Function, High Active, V _{IN} Sense, Detect L	3.00	3.30
XC6403/04DE86MR	CE Function, High Active, V _{IN} Sense, Detect L	3.50	3.80
XC6403/04FV87MR	Cd Function, V _{IN} Sense, Detect L	3.00	4.20
XC6403/04FV88MR	Cd Function, V _{IN} Sense, Detect L	3.30	4.00
XC6404DE89MR	CE Function, High Active, V _{IN} Sense, Detect L	1.20	2.00
XC6404DE90MR	CE Function, High Active, V _{IN} Sense, Detect L	1.30	2.00
XC6404DE91MR	CE Function, High Active, V _{IN} Sense, Detect L	1.50	2.00

■ ABSOLUTE MAXIMUM RATINGS

PARAMETER		SYMBOL	RATINGS	UNITS
Input Voltage		V _{IN}	7.0	V
VR Output Current		V _R OUT	700	mA
VR Output Voltage		V _R OUT	V _{SS} -0.3 ~ V _{IN} + 0.3	V
VD Output Current		V _D OUT	50	mA
VD Output Voltage		V _D OUT	V _{SS} -0.3 ~ 7.0	V
V _{CE} / V _{SEN} / Cd Pin Voltage		V _{CE} / V _{SEN} / Cd	V _{SS} -0.3 ~ V _{IN} + 0.3	V
Power Dissipation	SOT-25	P _d	250	mW
	SOT-89-5		500	
	USP-6B		100	
Operating Temperature Range		T _{opr}	- 40 ~ + 85	°C
Storage Temperature Range		T _{stg}	- 55 ~ + 125	°C

■ ELECTRICAL CHARACTERISTICS

XC6403/04 Series

T_a=25°C

	PARAMETER	SYMBOL	CONDITIONS	MIN.	TYP.	MAX.	UNITS	CIRCUIT
VOLTAGE REGULATOR	Output Voltage (*2, 3)	V _R OUT(E)	I _R OUT=30mA	× 0.98	V _R OUT(T)	× 1.02	V	①
	Maximum Output Current XC6403 (0.9~1.7V product)	I _R OUTMAX	V _{IN} = 3.1V	150	-	-	mA	①
	Maximum Output Current XC6403 (1.8~5.3V product)	I _R OUTMAX	V _{IN} =3.1V @ V _R OUT ≤ 2.1V	300	-	-	mA	①
	Maximum Output Current XC6404 (0.9~2.4V product)	I _R OUTMAX	V _{IN} =V _R OUT(T)+2.0V	400	-	-	mA	①
	Maximum Output Current XC6404 (2.5~4.9V product)	I _R OUTMAX	V _{IN} =V _R OUT(T)+2.0V When V _R OUT(T) ≥ 4.0V, V _{IN} =6.0V	500	-	-	mA	①
	Load Regulation	ΔV _R OUT	1mA ≤ I _R OUT ≤ 100mA	-	15	50	mV	①
	Dropout Voltage (*4)	V _{dif1}	I _R OUT=30mA	E-1			mV	①
		V _{dif2}	I _R OUT=100mA	E-2			mV	①
	Supply Current (No Pull-up Resistor)	I _{DD}	V _{IN} =V _R OUT(T)+1.0V, V _{EN} /CE=ON V _R OUT ≤ 0.9V, V _{IN} =2.0V, V _{EN} /CE =V _{IN} or V _{SS}	-	35	70	μA	②
	Supply Current (With Pull-up Resistor)	I _{DD}	V _{IN} =V _R OUT(T)+1.0V, V _{EN} /CE=ON V _R OUT ≤ 0.9V, V _{IN} =2.0V, V _{EN} /CE =V _{IN} or V _{SS}	-	40	75	μA	②
	Line Regulation	$\frac{\Delta V_{R}OUT}{\Delta V_{IN} \cdot V_{R}OUT}$	V _R OUT(T)+1.0V ≤ V _{IN} ≤ 6.0V When V _R OUT ≤ 0.9V, 2.0V ≤ V _{IN} ≤ 6.0V, I _R OUT=30mA, When V _R OUT ≤ 1.75V, I _R OUT=10mA	-	0.01	0.20	% / V	①
	Input Voltage	V _{IN}	-	2.0	-	6.0	V	-
	Output Voltage Temperature Characteristics	$\frac{\Delta V_{R}OUT}{\Delta T_{opr} \cdot V_{R}OUT}$	I _R OUT=30mA -40°C ≤ T _{opr} ≤ 85°C	-	± 100	-	ppm / °C	①
	Ripple Rejection Rate	PSRR	V _{IN} =[V _R OUT(T)+1.0]V+0.5V _{p-p} AC When V _R OUT(T) ≤ 1.25V → V _{IN} =2.25V+0.5V _{p-p} AC When V _R OUT(T) ≥ 4.75V → V _{IN} =5.75V+0.5V _{p-p} AC I _R OUT=50mA, f=10kHz	-	65	-	dB	③
	Current Limiter XC6403 (1.8V or more)	I _R lim	V _{IN} =3.1V @ V _R OUT ≤ 2.1V	300	380	-	mA	①
	Current Limiter XC6403 (1.7V or less)	I _R lim	V _{IN} =3.1V	-	380	-	mA	①
XC6403 Short-Circuit Current	I _R short	V _{IN} =3.1V @ V _R OUT ≤ 2.1V	-	50	-	mA	①	
Current Limiter XC6404 (2.4V or less)	I _R lim	V _{IN} =V _R OUT(T)+2.0V	-	600	-	mA	①	
Current Limiter XC6404 (2.5V or more)	I _R lim	V _{IN} =V _R OUT(T)+2.0V When V _R OUT(T) ≥ 4.0V, V _{IN} =6.0V	500	600	-	mA	①	
XC6404 Short-Circuit Current	I _R short	V _{IN} =V _R OUT(T)+2.0V When V _R OUT(T) ≥ 4.0V, V _{IN} =6.0V	-	50	-	mA	①	

■ ELECTRICAL CHARACTERISTICS (Continued)

XC6403/04 Series (Continued)

Ta=25°C

	PARAMETER	SYMBOL	CONDITIONS	MIN.	TYP.	MAX.	UNITS	CIRCUIT	
VOLTAGE DETECTOR	Detect Voltage (*7, 8)	VDF(E)	-	× 0.98	VDF(T)	× 1.02	V	④	
	Hysteresis Range (*7)	VHYS	-	VDF(T) × 0.02	VDF(T) × 0.05	VDF(T) × 0.08	V	④	
	Supply Current	IDDVD		VIN = 2.0V	-	6.5	14.5	μA	②
				VIN = 3.0V	-	7.0	15.0		
				VIN = 4.0V	-	7.5	15.5		
				VIN = 5.0V	-	8.0	16.0		
				VIN = 6.0V	-	9.0	17.0		
	Output Current (*9)	IDOUT	VDOUT = 0.5V	VIN = 2.0V	3.0	6.0	-	mA	⑤
				VIN = 3.0V	4.0	8.0	-		
				VIN = 4.0V	5.0	10.0	-		
VIN = 5.0V				7.0	12.0	-			
VIN = 6.0V				10.0	15.0	-			
Detect Voltage Temperature Characteristics	$\frac{\Delta VDF}{\Delta T_{opr} \cdot VDF}$		-40°C ≤ Topr ≤ 85°C	-	± 100	-	ppm/°C	④	
SWITCH (NO PULL-UP RESISTOR)									
	CE/EN "High" Level Voltage	VCE/EN H	-	1.60	-	VIN	V	①	
	CE/EN "Low" Level Voltage	VCE/EN L	-	-	-	0.25	V	①	
	CE/EN "High" Level Current	ICE/EN H	VCE/EN=VIN=VROUT(T)+1.0V	-0.10	-	5.00	μA	②	
	CE/EN "Low" Level Current	ICE/EN L	VIN=VROUT(T)+1.0V, VCE/EN=VSS	-0.10	-	0.10	μA	②	
OPTION									
	Delay Resistance	Rdelay	VIN=6.0V, Cd=0V Delay Resistance=6.0V/Delay Current	1.0	2.0	3.5	MΩ	⑥	

NOTE:

- *1 : Unless otherwise stated, VIN=VOUT(T)+1.0V
- *2 : VROUT(T)=Specified VR output voltage
- *3 : VOUT(E)=Effective VR output voltage
(i.e. the VR output voltage when "VROUT(T)+1.0V" is provided at the VIN pin while maintaining a certain IROUT value).
- *4 : Vdif={VIN1⁽⁶⁾-VROUT1⁽⁵⁾}
- *5 : A voltage equal to 98% of the VR output voltage whenever a stabilized VROUT1=IROUT{VROUT(T)+1.0V} is input.
- *6 : VIN1=The input voltage when VOUT1, which appears as input voltage is gradually decreased.
- *7 : VDF(T) : Specified detect voltage value
- *8 : VDF(E) : Effective detect voltage value. Refer to the E-0 chart for VDF(T) values less than 1.5V.
- *9 : VD output current value of Detect 'L' type equal to current value during detection and that of Detect 'H' type equal to current value before detection.

ELECTRICAL CHARACTERISTICS (Continued)

XC6403/04 AA / AD / AE / AH Series

Ta=25°C

	PARAMETER	SYMBOL	CONDITIONS	MIN.	TYP.	MAX.	UNITS	CIRCUIT	
VOLTAGE REGULATOR	Output Voltage (*2, 3)	V _{ROUT(E)}	I _{ROUT} =30mA	× 0.98	V _{ROUT(T)}	× 1.02	V	①	
	Maximum Output Current XC6403 (0.9~1.7V product)	I _{ROUTMAX}	V _{IN} = 3.1V	150	-	-	mA	①	
	Maximum Output Current XC6403 (1.8~5.3V product)	I _{ROUTMAX}	V _{IN} =3.1V @ V _{ROUT} ≤2.1V	300	-	-	mA	①	
	Maximum Output Current XC6404 (0.9~2.4V product)	I _{ROUTMAX}	V _{IN} =V _{ROUT(T)} +2.0V	400	-	-	mA	①	
	Maximum Output Current XC6404 (2.5~4.9V product)	I _{ROUTMAX}	V _{IN} =V _{ROUT(T)} +2.0V When V _{ROUT(T)} ≥4.0V, V _{IN} =6.0V	500	-	-	mA	①	
	Load Regulation	ΔV _{ROUT}	1mA≤I _{ROUT} ≤100mA	-	15	50	mV	①	
	Dropout Voltage (*4)	V _{dif1}	I _{ROUT} =30mA	E-1			mV	①	
		V _{dif2}	I _{ROUT} =100mA	E-2			mV	①	
	Supply Current (AA / AD Series)	I _{DD}	V _{IN} =V _{EN} =V _{ROUT(T)} +1.0V, When V _{ROUT} ≤0.9V, V _{IN} =2.0V	-	40	75	μA	②	
	Supply Current (AE / AH Series)	I _{DD}	V _{IN} =V _{EN} =V _{ROUT(T)} +1.0V, When V _{ROUT} ≤0.9V, V _{IN} =2.1V	-	35	70	μA	②	
	Line Regulation	$\frac{\Delta V_{ROUT}}{\Delta V_{IN} \cdot V_{ROUT}}$	V _{ROUT(T)} +1.0V≤V _{IN} ≤6.0V When V _{ROUT} ≤0.9V, 2.0V≤V _{IN} ≤6.0V, I _{ROUT} =30mA When V _{ROUT} ≤1.75V, I _{ROUT} =10mA	-	0.01	0.20	% / V	①	
	Input Voltage	V _{IN}	-	2.0	-	6.0	V	-	
	Output Voltage Temperature Characteristics	$\frac{\Delta V_{ROUT}}{\Delta T_{opr} \cdot V_{ROUT}}$	I _{ROUT} =30mA -40°C≤T _{opr} ≤85°C	-	±100	-	ppm / °C	①	
	Ripple Rejection Rate	PSRR	V _{IN} =[V _{ROUT(T)} +1.0]V+0.5Vp-pAC When V _{ROUT(T)} ≤1.25V → V _{IN} =2.25V+0.5Vp-pAC When V _{ROUT(T)} ≤4.75V → V _{IN} =5.75V+0.5Vp-pAC I _{ROUT} =50mA, f=10kHz	-	65	-	dB	③	
	Current Limiter XC6403 (1.8V or more)	I _{Rlim}	V _{IN} =3.1V @ V _{ROUT} ≤2.1V V _{EN} = V _{IN}	300	380	-	mA	①	
Current Limiter XC6403 (1.7V or less)	I _{Rlim}	V _{IN} =3.1V, V _{EN} =V _{IN}	-	380	-	mA	①		
XC6403 Short-Circuit Current	I _{Rshort}	V _{IN} =V _{ROUT(T)} +1.0V, V _{EN} =V _{IN} V _{IN} =3.1V @ V _{ROUT} ≤2.1V	-	50	-	mA	①		
Current Limiter XC6404 (2.4V or less)	I _{Rlim}	V _{IN} =V _{ROUT(T)} +2.0V	-	600	-	mA	①		
Current Limiter XC6404 (2.5V or more)	I _{Rlim}	V _{IN} =V _{ROUT(T)} +2.0V When V _{ROUT(T)} ≥4.0V, V _{IN} =6.0V	500	600	-	mA	①		
XC6404 Short-Circuit Current	I _{Rshort}	V _{IN} =V _{ROUT(T)} +2.0V When V _{ROUT(T)} ≥4.0V, V _{IN} =6.0V	-	50	-	mA	①		
VOLTAGE DETECTOR	Detect Voltage (*7, 8)	V _{DF(E)}	-	× 0.98	V _{DF(T)}	× 1.02	V	④	
	Hysteresis Range (*8)	V _{HYS}	-	V _{DF(T)} × 0.02	V _{DF(T)} × 0.05	V _{DF(T)} × 0.08	V	④	
	Supply Current (*9)	I _{DDVD}		V _{IN} = 2.0V	-	6.5	14.5	μA	②
				V _{IN} = 3.0V	-	7.0	15.0		
				V _{IN} = 4.0V	-	7.5	15.5		
				V _{IN} = 5.0V	-	8.0	16.0		
				V _{IN} = 6.0V	-	9.0	17.0		
	Output Current (*10)	I _{DOUT}	V _{DOUT} = 0.5V	V _{IN} = 2.0V	3.0	6.0	-		
				V _{IN} = 3.0V	4.0	8.0	-		
				V _{IN} = 4.0V	5.0	10.0	-		
V _{IN} = 5.0V				7.0	12.0	-			
Detect Voltage Temperature Characteristics	$\frac{\Delta V_{DF}}{\Delta T_{opr} \cdot V_{DF}}$	-40°C≤T _{opr} ≤85°C	-	±100	-	ppm / °C	④		

■ ELECTRICAL CHARACTERISTICS (Continued)

XC6403/04 AA / AD / AE / AH Series (Continued)

Ta=25°C

	PARAMETER	SYMBOL	CONDITIONS	MIN.	TYP.	MAX.	UNITS	CIRCUIT
SWITCH	EN "High" Level Voltage	VENH	-	1.60	-	VIN	V	①
	EN "Low" Level Voltage	VENL	-	-	-	0.25	V	①
	EN "High" Level Current (AA / AD Series)	IENH	VEN=VIN=VROUT(T)+1.0V	-0.10	-	5.00	μA	②
	EN "High" Level Current (AE / AH Series)	IENH	VEN=VIN=VROUT(T)+1.0V	-0.10	-	0.10	μA	②
	EN "Low" Level Current	IENL	VIN=VROUT(T)+1.0V, VEN=VSS	-0.10	-	0.10	μA	②

NOTE:

- *1 : Unless otherwise stated, VIN=VOUT(T)+1.0V
- *2 : VROUT(T)=Specified VR output voltage
- *3 : VOUT(E)=Effective VR output voltage
(i.e. the VR output voltage when "VROUT(T)+1.0V" is provided at the VIN pin while maintaining a certain IROUT value).
- *4 : $V_{dif} = \{V_{IN1}^{(6)} - V_{ROUT1}^{(5)}\}$
- *5 : A voltage equal to 98% of the VR output voltage whenever a stabilized VROUT1=IROUT{VROUT(T)+1.0V} is input.
- *6 : VIN1=The input voltage when VOUT1, which appears as input voltage is gradually decreased.
- *7 : VDF(T) : Specified detect voltage value
- *8 : VDF(E) : Effective detect voltage value. Refer to the E-0 chart for VDF(T) values less than 1.5V.
- *9 : VD supply current = supply current when VEN=VSS
- *10: VD output current = sink current during detection.

ELECTRICAL CHARACTERISTICS (Continued)

XC6403/04 CA / CD / CE / CH Series

Ta=25°C

	PARAMETER	SYMBOL	CONDITIONS	MIN.	TYP.	MAX.	UNITS	CIRCUIT
VOLTAGE REGULATOR	Output Voltage (*2, 3)	V _{ROUT(E)}	I _{ROUT} =30mA	× 0.98	V _{ROUT(T)}	× 1.02	V	①
	Maximum Output Current XC6403 (0.9~1.7V product)	I _{ROUTMAX}	V _{IN} = 3.1V	150	-	-	mA	①
	Maximum Output Current XC6403 (1.8~5.3V product)	I _{ROUTMAX}	V _{IN} =3.1V @ V _{ROUT} ≤2.1V	300	-	-	mA	①
	Maximum Output Current XC6404 (0.9~2.4V product)	I _{ROUTMAX}	V _{IN} =V _{ROUT(T)} +2.0V	400	-	-	mA	①
	Maximum Output Current XC6404 (2.5~4.9V product)	I _{ROUTMAX}	V _{IN} =V _{ROUT(T)} +2.0V When V _{ROUT(T)} ≥4.0V, V _{IN} =6.0V	500	-	-	mA	①
	Load Regulation	ΔV _{ROUT}	1mA≤I _{ROUT} ≤100mA	-	15	50	mV	①
	Dropout Voltage (*4)	V _{dif1}	I _{ROUT} =30mA	E-1			mV	①
		V _{dif2}	I _{ROUT} =100mA	E-2			mV	①
	Supply Current (CA / CD Series)	I _{DD}	V _{IN} =V _{EN} =V _{ROUT(T)} +1.0V, When V _{ROUT} ≤0.9V, V _{IN} =2.0V	-	40	75	μA	②
	Supply Current (CE / CH Series)	I _{DD}	V _{IN} =V _{EN} =V _{ROUT(T)} +1.0V, When V _{ROUT} ≤0.9V, V _{IN} =2.0V	-	35	70	μA	②
	Line Regulation	$\frac{\Delta V_{ROUT}}{\Delta V_{IN} \cdot V_{ROUT}}$	V _{ROUT(T)} +1.0V≤V _{IN} ≤6.0V When V _{ROUT} ≤0.9V, 2.0V≤V _{IN} ≤6.0V, I _{ROUT} =30mA When V _{ROUT} ≤1.75V, I _{ROUT} =10mA	-	0.01	0.20	% / V	①
	Input Voltage	V _{IN}	-	2.0		6.0	V	-
	Output Voltage Temperature Characteristics	$\frac{\Delta V_{ROUT}}{\Delta T_{opr} \cdot V_{ROUT}}$	I _{ROUT} =30mA -40°C≤T _{opr} ≤85°C	-	±100	-	ppm / °C	①
	Ripple Rejection Rate	PSRR	V _{IN} =[V _{ROUT(T)} +1.0]V+0.5V When V _{ROUT(T)} ≤1.25V → V _{IN} =2.25V+0.5Vp-pAC When V _{ROUT(T)} ≥4.75V → V _{IN} =5.75V+0.5Vp-pAC I _{ROUT} =50mA, f=10kHz	-	65	-	dB	③
	Current Limiter XC6403 (1.8V or more)	I _{Rlim}	V _{IN} =3.1V @ V _{ROUT} ≤2.1V V _{EN} =V _{IN}	300	380	-	mA	①
	Current Limiter XC6403 (1.7V or less)	I _{Rlim}	V _{IN} =3.1V, V _{EN} =V _{IN}	-	380	-	mA	①
	XC6403 Short-Circuit Current	I _{Rshort}	V _{IN} =V _{ROUT(T)} +1.0V, V _{EN} =V _{IN} V _{IN} =3.1V @ V _{ROUT} ≤2.1V	-	50	-	mA	①
Current Limiter XC6404 (2.4V or less)	I _{Rlim}	V _{IN} =V _{ROUT(T)} +2.0V	-	600	-	mA	①	
Current Limiter XC6404 (2.5V or more)	I _{Rlim}	V _{IN} =V _{ROUT(T)} +2.0V When V _{ROUT(T)} ≥4.0V, V _{IN} =6.0V	500	600	-	mA	①	
XC6404 Short-Circuit Current	I _{Rshort}	V _{IN} =V _{ROUT(T)} +2.0V When V _{ROUT(T)} ≥4.0V, V _{IN} =6.0V	-	50	-	mA	①	
VOLTAGE DETECTOR	Detect Voltage (*7, 8)	V _{DF(E)}	-	× 0.98	V _{DF(T)}	× 1.02	V	④
	Hysteresis Range (*8)	V _{HYS}	-	V _{DF(T)} × 0.02	V _{DF(T)} × 0.05	V _{DF(T)} × 0.08	V	④
	Supply Current (*9)	I _{DDVD}	V _{IN} = 2.0V	-	6.5	14.5	μA	②
			V _{IN} = 3.0V	-	7.0	15.0		
			V _{IN} = 4.0V	-	7.5	15.5		
			V _{IN} = 5.0V	-	8.0	16.0		
			V _{IN} = 6.0V	-	9.0	17.0		
	Output Current (*10)	I _{DOUT}	V _{DOUT} = 0.5V	V _{IN} = 2.0V	3.0	6.0	-	
				V _{IN} = 3.0V	4.0	8.0	-	
				V _{IN} = 4.0V	5.0	10.0	-	
V _{IN} = 5.0V				7.0	12.0	-		
V _{IN} = 6.0V				10.0	15.0	-		
Detect Voltage Temperature Characteristics	$\frac{\Delta V_{DF}}{\Delta T_{opr} \cdot V_{DF}}$	-40°C≤T _{opr} ≤85°C	-	±100	-	ppm / °C	④	

■ ELECTRICAL CHARACTERISTICS (Continued)

XC6403/04 CA / CD / CE / CH Series (Continued)

Ta=25°C

	PARAMETER	SYMBOL	CONDITIONS	MIN.	TYP.	MAX.	UNITS	CIRCUIT
SWITCH	EN "High" Level Voltage	VENH	-	1.6	-	VIN	V	①
	EN "Low" Level Voltage	VENL	-	-	-	0.25	V	①
	EN "High" Level Current (CA / CD Series)	IENH	VEN=VIN=VROUT(T)+1.0V	-0.10	-	5.00	μA	②
	EN "High" Level Current (CE / CH Series)	IENH	VEN=VIN=VROUT(T)+1.0V	-0.10	-	0.10	μA	②
	EN "Low" Level Current	IENL	VIN=VROUT(T)+1.0V, VEN=VSS	-0.10	-	0.10	μA	②

NOTE:

- *1 : Unless otherwise stated, $V_{IN}=V_{OUT(T)}+1.0V$
- *2 : $V_{ROUT(T)}$ =Specified VR output voltage
- *3 : $V_{OUT(E)}$ = Effective VR output voltage
(i.e. the VR output voltage when " $V_{ROUT(T)}+1.0V$ " is provided at the VIN pin while maintaining a certain IROUT value).
- *4 : $V_{dif}=\{V_{IN1}^{(6)}-V_{ROUT1}^{(5)}\}$
- *5 : A voltage equal to 98% of the VR output voltage whenever a stabilized $V_{ROUT1}=I_{ROUT}\{V_{ROUT(T)}+1.0V\}$ is input.
- *6 : V_{IN1} =The input voltage when V_{OUT1} , which appears as input voltage is gradually decreased.
- *7 : $V_{DF(T)}$: Specified detect voltage value
- *8 : $V_{DF(E)}$: Effective detect voltage value. Refer to the E-0 chart on page 15 for $V_{DF(T)}$ values less than 1.5V.
- *9 : VD supply current = supply current when $V_{EN}=V_{SS}$
- *10 : VD output current = sink current during detection.

ELECTRICAL CHARACTERISTICS (Continued)

XC6403/04 DA / DD / DE / DH Series

Ta=25°C

	PARAMETER	SYMBOL	CONDITIONS	MIN.	TYP.	MAX.	UNITS	CIRCUIT	
VOLTAGE REGULATOR	Output Voltage (*2, 3)	V _{ROUT(E)}	I _{ROUT} =30mA	× 0.98	V _{ROUT(T)}	× 1.02	V	①	
	Maximum Output Current XC6403 (0.9~1.7V product)	I _{ROUTMAX}	V _{IN} = 3.1V	150	-	-	mA	①	
	Maximum Output Current XC6403 (1.8~5.3V product)	I _{ROUTMAX}	V _{IN} =3.1V @ V _{ROUT} ≤ 2.1V	300	-	-	mA	①	
	Maximum Output Current XC6404 (0.9~2.4V product)	I _{ROUTMAX}	V _{IN} =V _{ROUT(T)} +2.0V	400	-	-	mA	①	
	Maximum Output Current XC6404 (2.5~4.9V product)	I _{ROUTMAX}	V _{IN} =V _{ROUT(T)} +2.0V When V _{ROUT(T)} ≥ 4.0V, V _{IN} =6.0V	500	-	-	mA	①	
	Load Regulation	ΔV _{ROUT}	1mA ≤ I _{ROUT} ≤ 100mA	-	15	50	mV	①	
	Dropout Voltage (*4)	V _{dif1}	I _{ROUT} =30mA	E-1			mV	①	
		V _{dif2}	I _{ROUT} =100mA	E-2			mV	①	
	Supply Current (DA / DD Series)	I _{DD}	V _{IN} =V _{VCE} =V _{ROUT(T)} +1.0V, When V _{ROUT} ≤ 0.9V, V _{IN} =2.0V	-	40	75	μA	②	
	Supply Current (DE / DH Series)	I _{DD}	V _{IN} =V _{VCE} =V _{ROUT(T)} +1.0V, When V _{ROUT} ≤ 0.9V, V _{IN} =2.0V	-	35	70	μA	②	
	Stand-by Current (DA / DD / DE / DH Series)	I _{DD}	V _{IN} =V _{ROUT(T)} +1.0V, V _{VCE} =0V, When V _{ROUT} ≤ 0.9V, V _{IN} =2.0V	-	0.01	0.10	% / V	②	
	Line Regulation	$\frac{\Delta V_{ROUT}}{\Delta V_{IN} \cdot V_{ROUT}}$	V _{ROUT(T)} +1.0V ≤ V _{IN} ≤ 6.0V When V _{ROUT} ≤ 0.9V, 2.0V ≤ V _{IN} ≤ 6.0V, I _{ROUT} =30mA When V _{ROUT} ≤ 1.75V, I _{ROUT} =10mA	-	0.01	0.20	% / V	①	
	Input Voltage	V _{IN}	-	2.0	-	6.0	V	-	
	Output Voltage Temperature Characteristics	$\frac{\Delta V_{ROUT}}{\Delta T_{opr} \cdot V_{ROUT}}$	I _{ROUT} =30mA -40°C ≤ T _{opr} ≤ 85°C	-	± 100	-	ppm / °C	①	
	Ripple Rejection Rate	PSRR	V _{IN} =[V _{ROUT(T)} +1.0]V+0.5V _{p-pAC} When V _{ROUT(T)} ≤ 1.25V → V _{IN} =2.25V+0.5V _{p-pAC} When V _{ROUT(T)} ≥ 4.75V → V _{IN} =5.75V+0.5V _{p-pAC} I _{ROUT} =50mA, f=10kHz	-	65	-	dB	③	
	Current Limiter XC6403 (1.8V or more)	I _{Rlim}	V _{IN} =3.1V @ V _{ROUT} ≤ 2.1V V _{VCE} = V _{IN}	300	380	-	mA	①	
	Current Limiter XC6403 (1.7V or less)	I _{Rlim}	V _{IN} =3.1V, V _{VCE} = V _{IN}	-	380	-	mA	①	
	XC6403 Short-Circuit Current	I _{Rshort}	V _{IN} =V _{ROUT(T)} +1.0V, V _{VCE} = V _{IN} V _{IN} =3.1V @ V _{ROUT} ≤ 2.1V	-	50	-	mA	①	
Current Limiter XC6404 (2.4V or less)	I _{Rlim}	V _{IN} =V _{ROUT(T)} +2.0V	-	600	-	mA	①		
Current Limiter XC6404 (2.5V or more)	I _{Rlim}	V _{IN} =V _{ROUT(T)} +2.0V, When V _{ROUT(T)} ≥ 4.0V, V _{IN} =6.0V	500	600	-	mA	①		
XC6404 Short-Circuit Current	I _{Rshort}	V _{IN} =V _{ROUT(T)} +2.0V, When V _{ROUT(T)} ≥ 4.0V, V _{IN} =6.0V	-	50	-	mA	①		
VOLTAGE DETECTOR	Detect Voltage (*7, 8)	V _{DF(E)}	-	× 0.98	V _{DF(T)}	× 1.02	V	④	
	Hysteresis Range (*8)	V _{HYS}	-	V _{DF(T)} × 0.02	V _{DF(T)} × 0.05	V _{DF(T)} × 0.08	V	④	
	Supply Current (*9)	I _{DOUT}	V _{DOUT} = 0.5V	V _{IN} = 2.0V	3.0	6.0	-	mA	⑤
				V _{IN} = 3.0V	4.0	8.0	-		
				V _{IN} = 4.0V	5.0	10.0	-		
V _{IN} = 5.0V				7.0	12.0	-			
Detect Voltage Temperature Characteristics	$\frac{\Delta V_{DF}}{\Delta T_{opr} \cdot V_{DF}}$	-40°C ≤ T _{opr} ≤ 85°C	-	± 100	-	ppm / °C	④		

■ ELECTRICAL CHARACTERISTICS (Continued)

XC6403/04 DA / DD / DE / DH Series (Continued)

Ta=25°C

	PARAMETER	SYMBOL	CONDITIONS	MIN.	TYP.	MAX.	UNITS	CIRCUIT
SWITCH	CE "High" Level Voltage	VCEH	-	1.6	-	V _{IN}	V	①
	CE "Low" Level Voltage	VCEL	-	-	-	0.25	V	①
	CE "High" Level Current (DA / DD Series)	ICEH	VCE=V _{IN} =V _{ROUT(T)} +1.0V	-0.10	-	5.00	μA	②
	CE "High" Level Current (DE / DH Series)	ICEH	VCE=V _{IN} =V _{ROUT(T)} +1.0V	-0.10	-	0.10	μA	②
	CE "Low" Level Current	ICEL	V _{IN} =V _{ROUT(T)} +1.0V, VCE=V _{SS}	-0.10	-	0.10	μA	②

NOTE:

- *1 : Unless otherwise stated, V_{IN}=V_{OUT(T)}+1.0V
- *2 : V_{ROUT(T)}=Specified VR output voltage
- *3 : V_{OUT(E)}= Effective VR output voltage
(i.e. the VR output voltage when "V_{ROUT(T)}+1.0V" is provided at the V_{IN} pin while maintaining a certain I_{ROUT} value).
- *4 : V_{dif}={V_{IN1}⁽⁶⁾-V_{ROUT1}⁽⁵⁾}
- *5 : A voltage equal to 98% of the VR output voltage whenever a stabilized V_{ROUT1}=I_{ROUT}{V_{ROUT(T)}+1.0V} is input.
- *6 : V_{IN1}=The input voltage when V_{OUT1}, which appears as input voltage is gradually decreased.
- *7 : V_{DF(T)}: Specified detect voltage value
- *8 : V_{DF(E)}: Effective detect voltage value. Refer to the E-0 chart for V_{DF(T)} values less than 1.5V.
- *9 : V_D output current = sink current during detection.

ELECTRICAL CHARACTERISTICS (Continued)

XC6403/04 EV / EX Series

Ta=25°C

	PARAMETER	SYMBOL	CONDITIONS	MIN.	TYP.	MAX.	UNITS	CIRCUIT	
VOLTAGE REGULATOR	Output Voltage	V _{ROUT(E)}	I _{ROUT} =30mA	× 0.98	V _{ROUT(T)}	× 1.02	V	①	
	Maximum Output Current XC6403 (0.9~1.7V product)	I _{ROUTMAX}	V _{IN} = 3.1V	150	-	-	mA	①	
	Maximum Output Current XC6403 (1.8~5.3V product)	I _{ROUTMAX}	V _{IN} =3.1V @ V _{ROUT} ≤ 2.1V	300	-	-	mA	①	
	Maximum Output Current XC6404 (0.9~2.4V product)	I _{ROUTMAX}	V _{IN} =V _{ROUT(T)} +2.0V	400	-	-	mA	①	
	Maximum Output Current XC6404 (2.5~4.9V product)	I _{ROUTMAX}	V _{IN} =V _{ROUT(T)} +2.0V When V _{ROUT(T)} ≥ 4.0V, V _{IN} =6.0V	500	-	-	mA	①	
	Load Regulation	ΔV _{ROUT}	1mA ≤ I _{ROUT} ≤ 100mA	-	15	50	mV	①	
	Dropout Voltage	V _{dif1}	I _{ROUT} =30mA	E-1			mV	①	
		V _{dif2}	I _{ROUT} =100mA	E-2			mV	①	
	Supply Current (EV / EX Series)	I _{DD}	V _{IN} =V _{ROUT(T)} +1.0V, When V _{ROUT} ≤ 0.9V, V _{IN} =2.0V	-	35	70	μA	②	
	Line Regulation	$\frac{\Delta V_{ROUT}}{\Delta V_{IN} \cdot V_{ROUT}}$	V _{IN} =V _{ROUT(T)} +1.0V, V _{ROUT(T)} +1.0V ≤ V _{IN} ≤ 6.0V When V _{ROUT} ≤ 0.9V, 2.0V ≤ V _{IN} ≤ 6.0V, I _{ROUT} =30mA When V _{ROUT} ≤ 1.75V, I _{ROUT} =10mA	-	0.01	0.20	% / V	①	
	Input Voltage	V _{IN}	-	2.0	-	6.0	V	-	
	Output Voltage Temperature Characteristics	$\frac{\Delta V_{ROUT}}{\Delta T_{opr} \cdot V_{ROUT}}$	I _{ROUT} =30mA -40°C ≤ T _{opr} ≤ 85°C	-	±100	-	ppm/°C	①	
	Ripple Rejection Rate	PSRR	V _{IN} =[V _{ROUT(T)} +1.0]V+0.5Vp-pAC When V _{ROUT(T)} ≤ 1.25V → V _{IN} =2.25V+0.5Vp-pAC When V _{ROUT(T)} ≥ 4.75V → V _{IN} =5.75V+0.5Vp-pAC I _{ROUT} =50mA, f=10kHz	-	65	-	dB	③	
	Current Limiter XC6403 (1.8V or more)	I _{Rlim}	V _{IN} =3.1V @ V _{ROUT} ≤ 2.1V	300	380	-	mA	①	
	Current Limiter XC6403 (1.7V or less)	I _{Rlim}	V _{IN} =3.1V	-	380	-	mA	①	
	XC6403 Short-Circuit Current	I _{Rshort}	V _{IN} =V _{ROUT(T)} +1.0V V _{IN} =3.1V @ V _{ROUT} ≤ 2.1V	-	50	-	mA	①	
Current Limiter XC6404 (2.4V or less)	I _{Rlim}	V _{IN} =V _{ROUT(T)} +2.0V	-	600	-	mA	①		
Current Limiter XC6404 (2.5V or more)	I _{Rlim}	V _{IN} =V _{ROUT(T)} +2.0V When V _{ROUT(T)} ≥ 4.0V, V _{IN} =6.0V	500	600	-	mA	①		
XC6404 Short-Circuit Current	I _{Rshort}	V _{IN} =V _{ROUT(T)} +2.0V When V _{ROUT(T)} ≥ 4.0V, V _{IN} =6.0V	-	50	-	mA	①		
VOLTAGE DETECTOR	Detect Voltage	V _{DF(E)}	-	× 0.98	V _{DF(T)}	× 1.02	V	④	
	Hysteresis Range	V _{HYS}	-	V _{DF(T)} × 0.02	V _{DF(T)} × 0.05	V _{DF(T)} × 0.08	V	④	
	Supply Current (*9)	I _{DOUT}	V _{DOUT} = 0.5V	V _{IN} = 2.0V	3.0	6.0	-	mA	⑤
				V _{IN} = 3.0V	4.0	8.0	-		
				V _{IN} = 4.0V	5.0	10.0	-		
V _{IN} = 5.0V				7.0	12.0	-			
Detect Voltage Temperature Characteristics	$\frac{\Delta V_{DF}}{\Delta T_{opr} \cdot V_{DF}}$	-40°C ≤ T _{opr} ≤ 85°C	-	±100	-	ppm/°C	④		

NOTE:

- *1 : Unless otherwise stated, V_{IN}=V_{OUT(T)}+1.0V
- *2 : V_{ROUT(T)}=Specified VR output voltage
- *3 : V_{OUT(E)}=Actual VR output voltage.
(i.e. the VR output voltage when "V_{ROUT(T)}+1.0V" is provided at the V_{IN} pin while maintaining a certain I_{ROUT} value).
- *4 : V_{dif}={V_{IN1}⁽⁶⁾-V_{ROUT1}^{(5)}}
- *5 : A voltage equal to 98% of the VR output voltage whenever a stabilized V_{ROUT1}=I_{ROUT}(V_{ROUT(T)}+1.0V) is input.
- *6 : V_{IN1}=The input voltage when V_{OUT1}, which appears as input voltage is gradually decreased.
- *7 : V_{DF(T)} : Specified detect voltage value
- *8 : V_{DF(E)} : Actual detect voltage value. Refer to the E-0 chart for V_{DF(T)} less than 1.5V.
- *9 : V_D output current = sink current during detection.

■ ELECTRICAL CHARACTERISTICS (Continued)

XC6403/04 FV / FX / FY / FZ Series

Ta=25°C

	PARAMETER	SYMBOL	CONDITIONS	MIN.	TYP.	MAX.	UNITS	CIRCUIT	
VOLTAGE REGULATOR	Output Voltage (*2, 3)	V _{ROUT(E)}	I _{ROUT} =30mA	× 0.98	V _{ROUT(T)}	× 1.02	V	①	
	Maximum Output Current XC6403 (0.9~1.7V product)	I _{ROUTMAX}	V _{IN} = 3.1V	150	-	-	mA	①	
	Maximum Output Current XC6403 (1.8~5.3V product)	I _{ROUTMAX}	V _{IN} =3.1V @ V _{ROUT} ≤2.1V	300	-	-	mA	①	
	Maximum Output Current XC6404 (0.9~2.4V product)	I _{ROUTMAX}	V _{IN} =V _{ROUT(T)} +2.0V	400	-	-	mA	①	
	Maximum Output Current XC6404 (2.5~4.9V product)	I _{ROUTMAX}	V _{IN} =V _{ROUT(T)} +2.0V When V _{ROUT(T)} ≥4.0V, V _{IN} =6.0V	500	-	-	mA	①	
	Load Regulation	ΔV _{ROUT}	1mA≤I _{ROUT} ≤100mA	-	15	50	mV	①	
	Dropout Voltage (*4)	V _{dif1}	I _{ROUT} =30mA	E-1			mV	①	
		V _{dif2}	I _{ROUT} =100mA	E-2			mV	①	
	Supply Current (FV / FX / FY / FZ Series)	I _{DD}	V _{IN} =V _{ROUT(T)} +1.0V, When V _{ROUT} ≤0.9V, V _{IN} =2.0V	-	35	70	μA	②	
	Line Regulation	$\frac{\Delta V_{ROUT}}{\Delta V_{IN} \cdot V_{ROUT}}$	V _{ROUT(T)} +1.0V≤V _{IN} ≤6.0V When V _{ROUT} ≤0.9V, 2.0V≤V _{IN} ≤6.0V, I _{ROUT} =30mA When V _{ROUT} ≤1.75V, I _{ROUT} =10mA	-	0.01	0.20	% / V	①	
	Input Voltage	V _{IN}	-	2.0	-	6.0	V	-	
	Output Voltage Temperature Characteristics	$\frac{\Delta V_{ROUT}}{\Delta T_{opr} \cdot V_{ROUT}}$	I _{ROUT} =30mA -40°C≤T _{opr} ≤85°C	-	±100	-	ppm / °C	①	
	Ripple Rejection Rate	PSRR	V _{IN} =[V _{ROUT(T)} +1.0]V+0.5V _{p-pAC} When V _{ROUT(T)} ≤1.25V → V _{IN} =2.25V+0.5V _{p-pAC} When V _{ROUT(T)} ≥4.75V → V _{IN} =5.75V+0.5V _{p-pAC} I _{ROUT} =50mA, f=10kHz	-	65	-	dB	③	
	Current Limiter XC6403 (1.8V or more)	I _{Rlim}	V _{IN} =3.1V @ V _{ROUT} ≤2.1V	300	380	-	mA	①	
	Current Limiter XC6403 (1.7V or less)	I _{Rlim}	V _{IN} =3.1V	-	380	-	mA	①	
	XC6403 Short-Circuit Current	I _{Rshort}	V _{IN} =V _{ROUT(T)} +1.0V, V _{IN} =3.1V @ V _{ROUT} ≤2.1V	-	50	-	mA	①	
	Current Limiter XC6404 (2.4V or less)	I _{Rlim}	V _{IN} =V _{ROUT(T)} +2.0V	-	600	-	mA	①	
	Current Limiter XC6404 (2.5V or more)	I _{Rlim}	V _{IN} =V _{ROUT(T)} +2.0V When V _{ROUT(T)} ≥4.0V, V _{IN} =6.0V	500	600	-	mA	①	
XC6404 Short-Circuit Current	I _{Rshort}	V _{IN} =V _{ROUT(T)} +2.0V When V _{ROUT(T)} ≥4.0V, V _{IN} =6.0V	-	50	-	mA	①		
VOLTAGE DETECTOR	Detect Voltage (*7, 8)	V _{DF(E)}	-	× 0.98	V _{DF(T)}	× 1.02	V	④	
	Hysteresis Range (*8)	V _{HYS}	-	V _{DF(T)} × 0.02	V _{DF(T)} × 0.05	V _{DF(T)} × 0.08	V	④	
	Output Current (*9)	I _{DOUT}	V _{DOUT} = 0.5V	V _{IN} = 2.0V	3.0	6.0	-	mA	⑤
				V _{IN} = 3.0V	4.0	8.0	-		
				V _{IN} = 4.0V	5.0	10.0	-		
				V _{IN} = 5.0V	7.0	12.0	-		
Detect Voltage Temperature Characteristics	$\frac{\Delta V_{DF}}{\Delta T_{opr} \cdot V_{DF}}$	-40°C≤T _{opr} ≤85°C	-	±100	-	ppm / °C	④		
Delay Resistance	R _{delay}	V _{IN} =6.0V, C _d =0V Delay Resistance=6.0V/Delay Current	1.0	2.0	3.5	MΩ	⑥		

NOTE:

- *1 : Unless otherwise stated, V_{IN}=V_{OUT(T)}+1.0V
- *2 : V_{ROUT(T)}=Specified VR output voltage
- *3 : V_{OUT(E)}=Actual VR output voltage
(i.e. the VR output voltage when "V_{ROUT(T)}+1.0V" is provided at the V_{IN} pin while maintaining a certain I_{ROUT} value).
- *4 : V_{dif}={V_{IN1}⁽⁶⁾-V_{ROUT1}⁽⁵⁾}
- *5 : A voltage equal to 98% of the VR output voltage whenever a stabilized V_{ROUT1}=I_{ROUT}{V_{ROUT(T)}+1.0V} is input.
- *6 : V_{IN1}=The input voltage when V_{OUT1}, which appears as Input voltage is gradually decreased.
- *7 : V_{DF(T)}: Specified detect voltage value
- *8 : V_{DF(E)}: Actual detect voltage value. Refer to the E-0 chart for V_{DF(T)} values less than 1.5V.
- *9 : V_D supply current = sink current during detection.

■ ELECTRICAL CHARACTERISTICS (Continued)

● VR Dropout Voltage 1

XC6403/6404

SYMBOL		E-0		E-1		E-1	
SPECIFIED DETECT VOLTAGE OUTPUT VOLTAGE	PARAMETER	OUTPUT VOLTAGE DETECT VOLTAGE (V)		DROPOUT VOLTAGE 1 (mV) (I _{OUT} =30mA)		DROPOUT VOLTAGE 2 (mV) (I _{OUT} =100mA)	
				Ta=25°C		Ta=25°C	
		V _{ROUT} / V _{DF}		V _{dif1}	V _{dif1}	V _{dif2}	V _{dif2}
V _{ROUT(T)} V _{DF(T)}		MIN.	MAX.	TYP.	MAX.	TYP.	MAX.
0.90		0.870	0.930	1050	1100	1150	1200
1.00		0.970	1.030	1000	1100	1050	1200
1.10		1.070	1.130	900	1000	950	1100
1.20		1.170	1.230	800	900	850	1000
1.30		1.270	1.330	700	800	750	900
1.40		1.370	1.430	600	700	650	800
1.50		1.470	1.530	500	600	550	700
1.60		1.568	1.632	400	500	500	600
1.70		1.666	1.734	300	400	400	500
1.80		1.764	1.836	200	300	300	400
1.90		1.862	1.938	120	150	280	380
2.00		1.960	2.040	80	120	240	350
2.10		2.058	2.142	80	120	240	330
2.20		2.156	2.244	80	120	240	330
2.30		2.254	2.346	80	120	240	310
2.40		2.352	2.448	80	120	240	310
2.50		2.450	2.550	70	100	220	290
2.60		2.548	2.652	70	100	220	290
2.70		2.646	2.754	70	100	220	290
2.80		2.744	2.856	70	100	220	270
2.90		2.842	2.958	70	100	220	270
3.00		2.940	3.060	60	90	200	270
3.10		3.038	3.162	60	90	200	250
3.20		3.136	3.264	60	90	200	250
3.30		3.234	3.366	60	90	200	250
3.40		3.332	3.468	60	90	200	250
3.50		3.430	3.570	60	90	200	250
3.60		3.528	3.672	60	90	200	250
3.70		3.626	3.774	60	90	200	250
3.80		3.724	3.876	60	90	200	250
3.90		3.822	3.978	60	90	200	250
4.00		3.920	4.080	60	80	180	230
4.10		4.018	4.182	60	80	180	230
4.20		4.116	4.284	60	80	180	230
4.30		4.214	4.386	60	80	180	230
4.40		4.312	4.488	60	80	180	230
4.50		4.410	4.590	60	80	180	230

■ ELECTRICAL CHARACTERISTICS (Continued)

● VR Dropout Voltage 2

XC6403

SYMBOL		E-0		E-1		E-1	
SPECIFIED DETECT VOLTAGE OUTPUT VOLTAGE	PARAMETER	OUTPUT VOLTAGE DETECT VOLTAGE (V)		DROPOUT VOLTAGE 1 (mV) (I _{OUT} =30mA)		DROPOUT VOLTAGE 2 (mV) (I _{OUT} =100mA)	
				Ta=25°C		Ta=25°C	
V _{ROUT(T)} V _{DF(T)}	V _{ROUT} / V _{DF}			V _{dif1}	V _{dif1}	V _{dif2}	V _{dif2}
		MIN.	MAX.	TYP.	MAX.	TYP.	MAX.
4.60		4.508	4.692	60	80	180	230
4.70		4.606	4.794	60	80	180	230
4.80		4.704	4.896	60	80	180	230
4.90		4.802	4.998	60	80	180	230
5.00		4.900	5.100	50	70	160	210
5.10		4.998	5.202	50	70	160	210
5.20		5.096	5.304	50	70	160	210
5.30		5.194	5.406	50	70	160	210
5.40		5.292	5.508	50	70	160	210
5.50		5.390	5.610	50	70	160	210
5.60		5.488	5.712	50	70	160	210

XC6404

SYMBOL		E-0		E-1		E-1	
SPECIFIED DETECT VOLTAGE OUTPUT VOLTAGE	PARAMETER	OUTPUT VOLTAGE DETECT VOLTAGE (V)		DROPOUT VOLTAGE 1 (mV) (I _{OUT} =30mA)		DROPOUT VOLTAGE 2 (mV) (I _{OUT} =100mA)	
				Ta=25°C		Ta=25°C	
V _{ROUT(T)} V _{DF(T)}	V _{ROUT} / V _{DF}			V _{dif1}	V _{dif1}	V _{dif2}	V _{dif2}
		MIN.	MAX.	TYP.	MAX.	TYP.	MAX.
4.60		4.508	4.692	60	80	180	230
4.70		4.606	4.794	60	80	180	230
4.80		4.704	4.896	60	80	180	230
4.90		4.802	4.998	60	80	180	230
5.00		4.900	5.100	50	70	160	210
5.10		4.998	5.202	50	70	160	210
5.20		5.096	5.304				
5.30		5.194	5.406				
5.40		5.292	5.508				
5.50		5.390	5.610				

TEST CIRCUITS

● Circuit ①

XC6403/04A ~ C Series

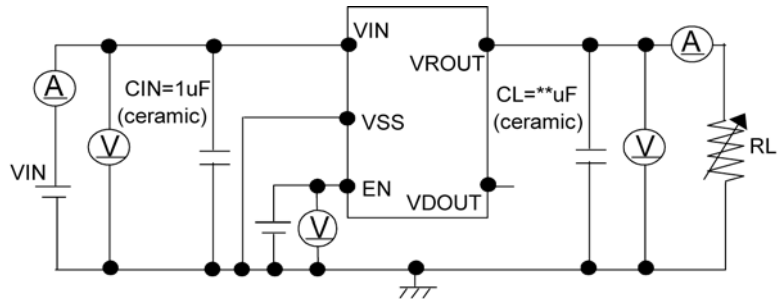

XC6403/04D Series

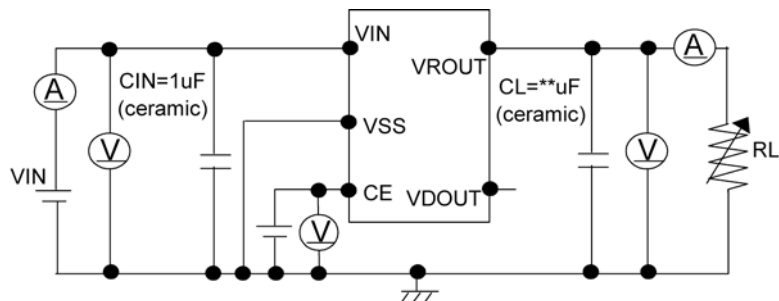

XC6403/04E Series

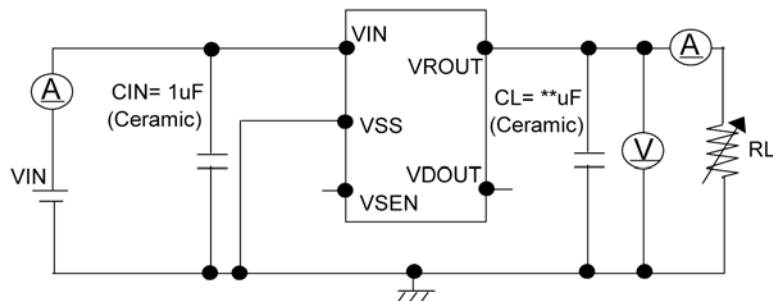

XC6403/04F Series

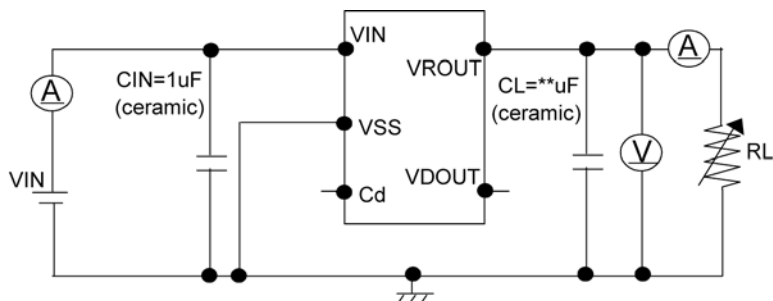

Output Capacitor Corresponding Chart

VROUT	0.9 ~ 1.2V	1.3 ~ 1.7V	1.8V ~
CL	More Than 4.7 μ F	More Than 2.2 μ F	More Than 1.0 μ F

■ TEST CIRCUITS (Continued)

● Circuit ②

XC6403/04A ~ C Series

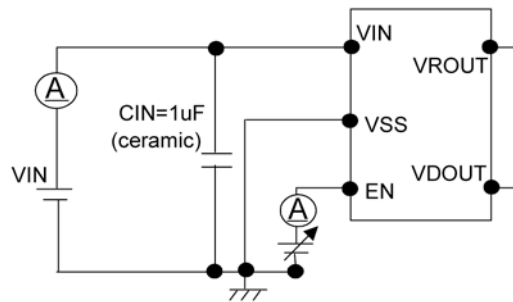

XC6403/04D Series

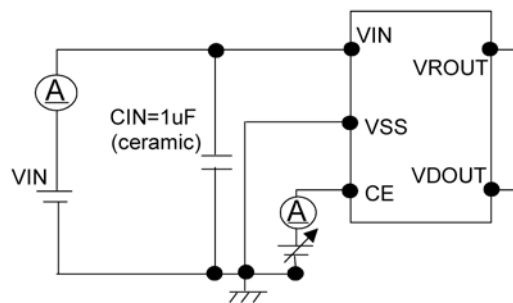

XC6403/04E Series

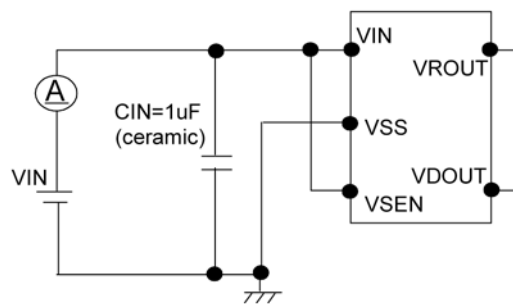

XC6403/04F Series

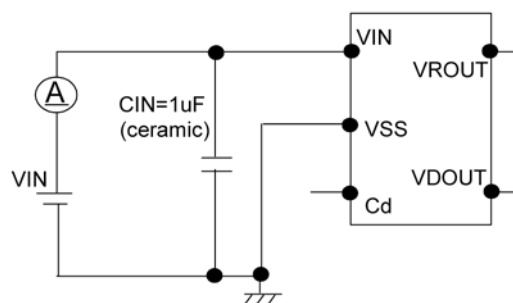

TEST CIRCUITS (Continued)

● Circuit ③

XC6403/04A ~ C Series

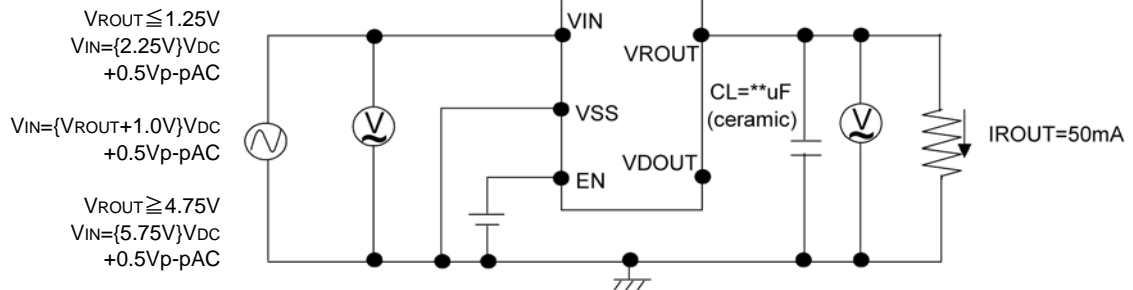

XC6403/04D Series

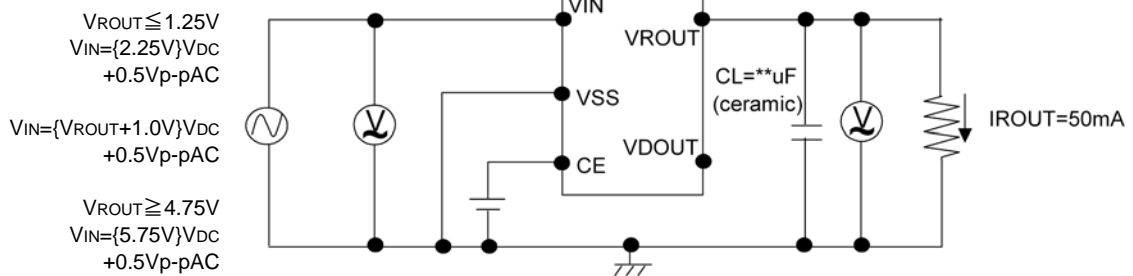

XC6403/04E Series

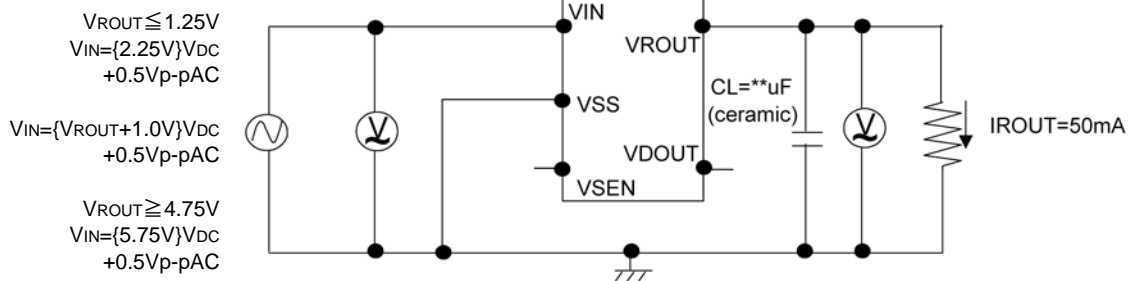

XC6403/04F Series

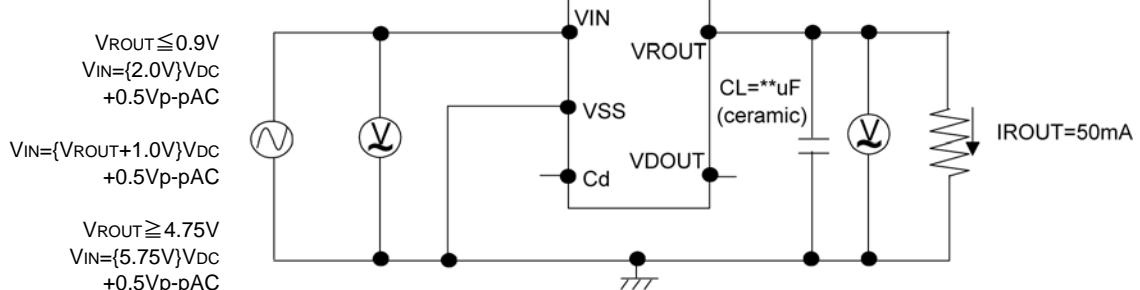

Output Capacitor Corresponding Chart

V_{ROUT}	0.9 ~ 1.2V	1.3 ~ 1.7V	1.8 ~
CL	More Than $4.7 \mu F$	More Than $2.2 \mu F$	More Than $1.0 \mu F$

TEST CIRCUITS (Continued)

● Circuit ④

XC6403/04A ~ C Series

[VD Sense, VIN Type]

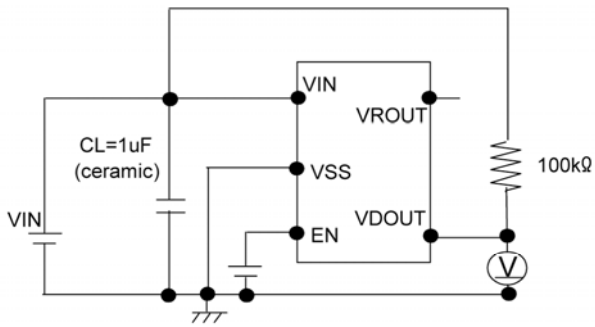

[VD Sense, VROUT Type]

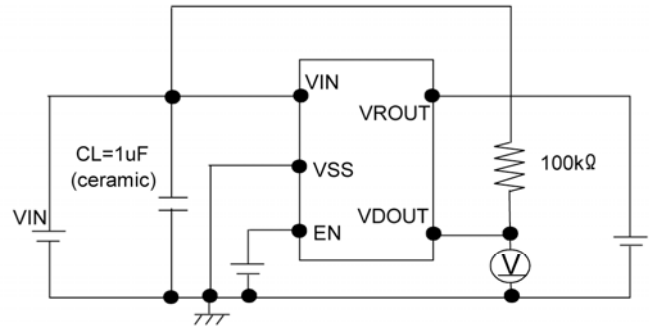

XC6403/04D Series

[VD Sense, VIN Type]

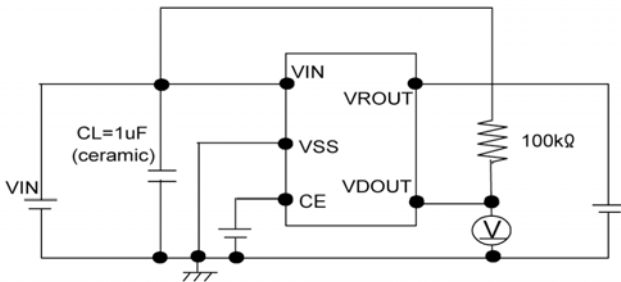

[VD Sense, VROUT Type]

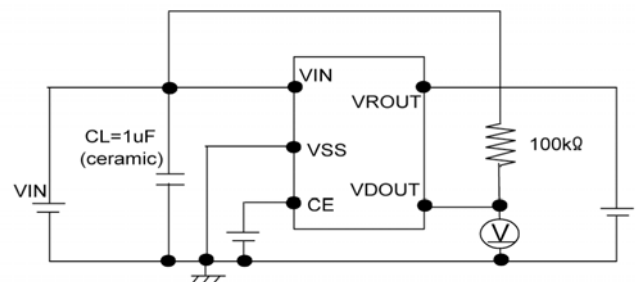

XC6403/04E Series

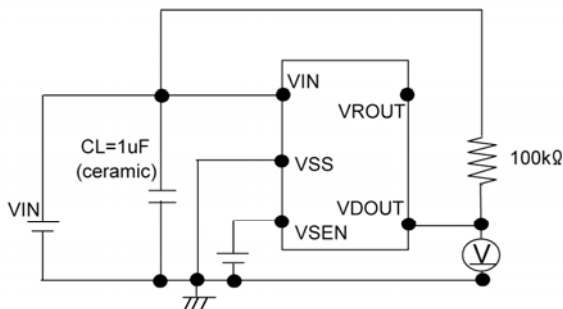

XC6403/04F Series

[VD Sense, VIN Type]

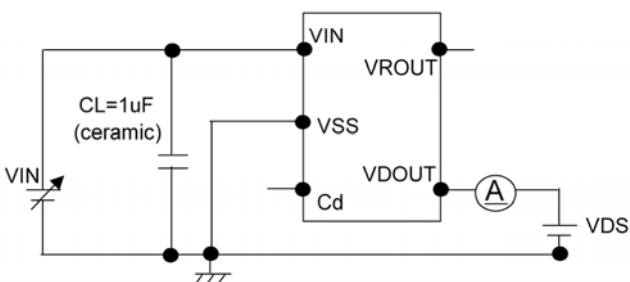

[VD Sense, VROUT Type]

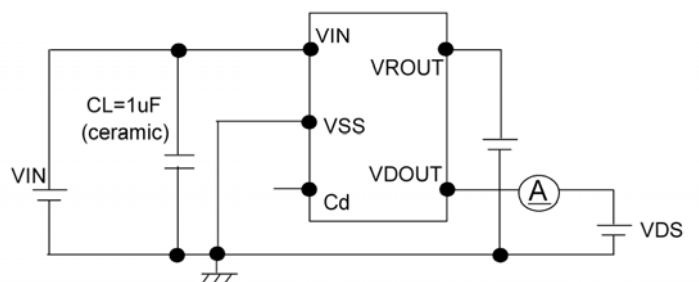

TEST CIRCUITS (Continued)

● Circuit ⑤

XC6403/04A ~ C Series

[VD Sense, VIN Type]

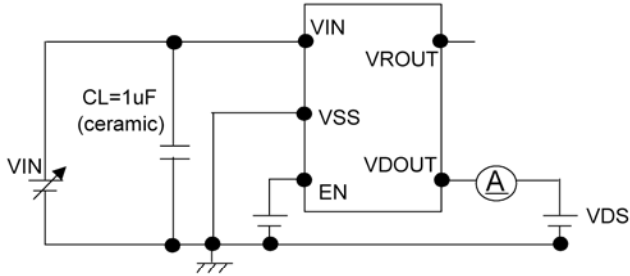

[VD Sense, VROUT Type]

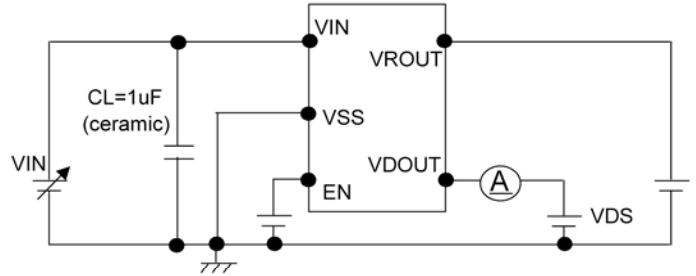

XC6403/04D Series

[VD Sense, VIN Type]

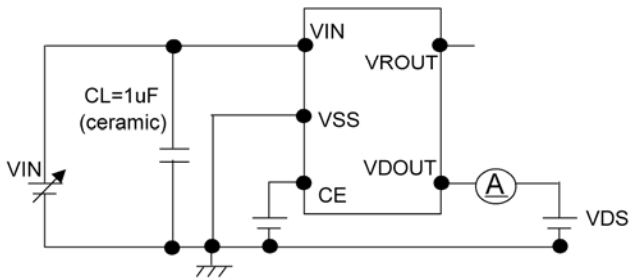

[VD Sense, VROUT Type]

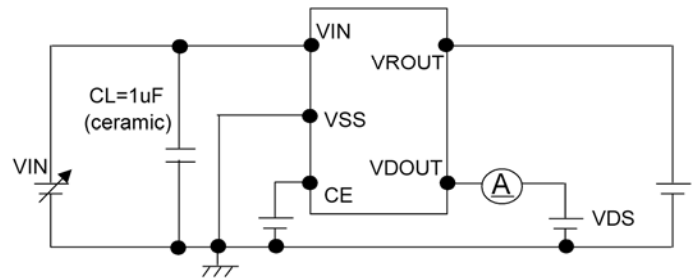

XC6403/04E Series

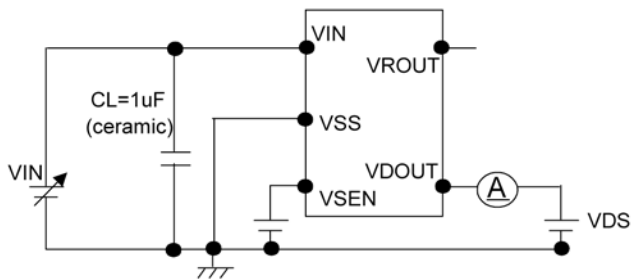

XC6403/04F Series

[VD Sense, VIN Type]

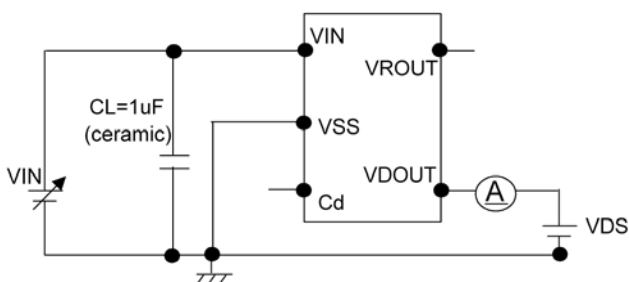

[VD Sense, VROUT Type]

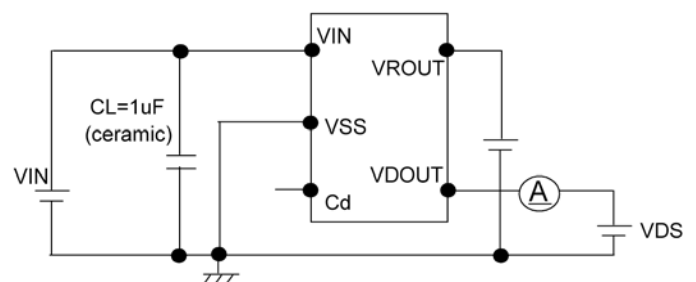

■ TEST CIRCUITS (Continued)

● Circuit ⑥

XC6403/04F Series
[VD Sense, VIN Type]

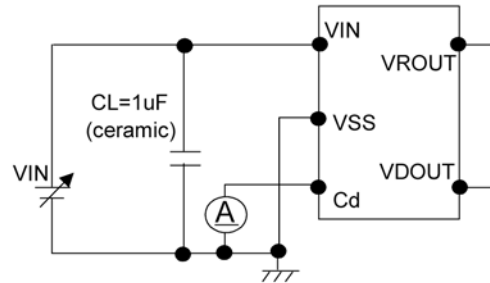

[VD Sense, VROUT Type]

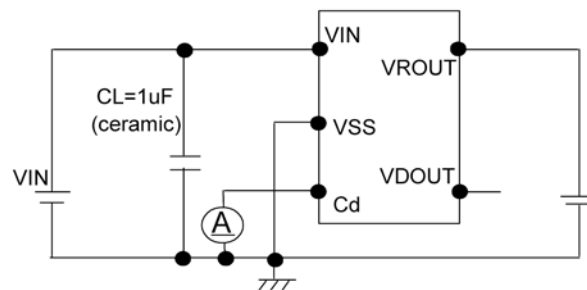

■ BLOCK DIAGRAMS

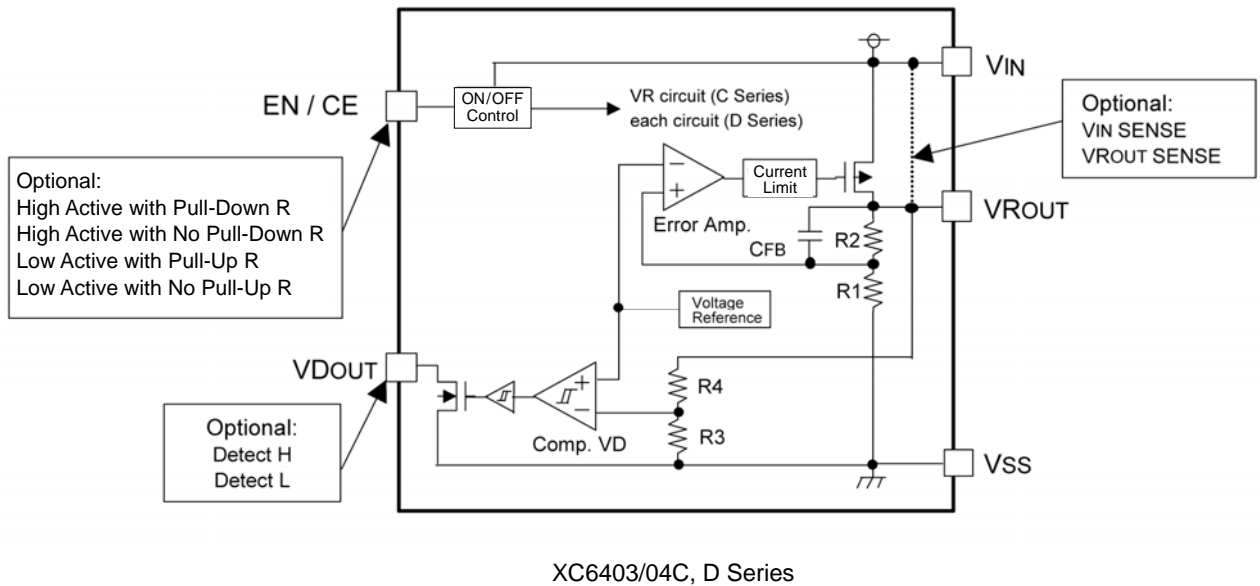
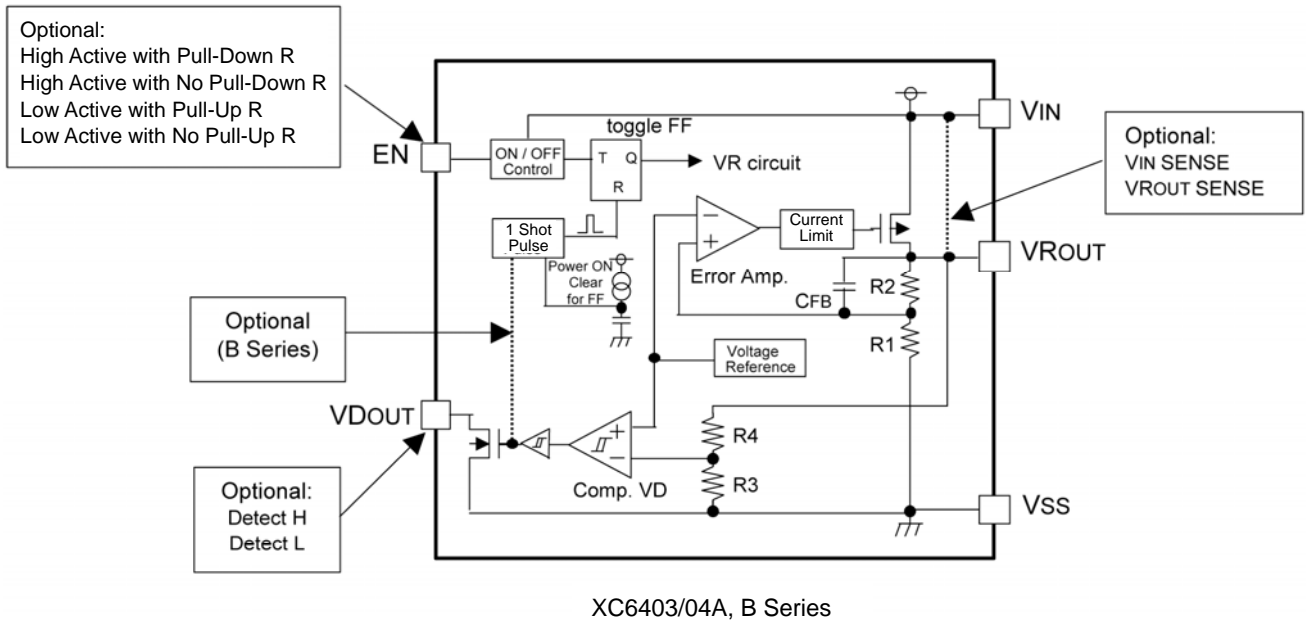

■ BLOCK DIAGRAMS (Continued)

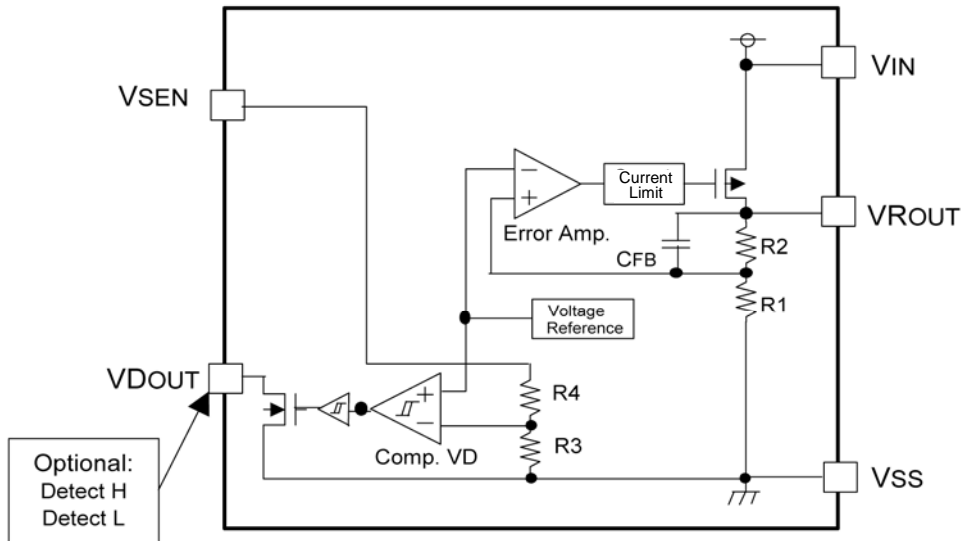

XC6403/04E Series

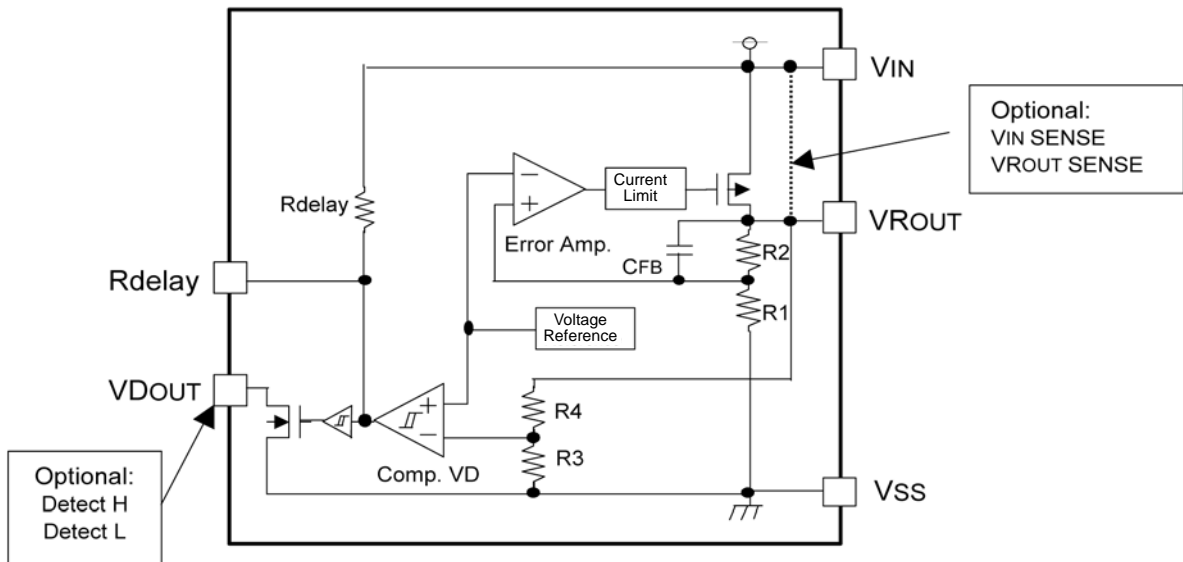

XC6403/04F Series

OPERATIONAL EXPLANATION

<Output Voltage Regulator Control>

The voltage, divided by resistors R1 & R2 which are connected to the V_{ROUT} pin is compared with the internal reference voltage by the error amplifier. The P-channel MOSFET, which is connected to the V_{ROUT} pin, is then driven by the subsequent output signal. The output voltage at the V_{ROUT} pin is controlled & stabilized by negative feedback. The current limit circuit and short circuit protection operate in relation to the level of output current. Further, the voltage regulator's internal circuitry can be shutdown via the EN or CE pin's signal.

<Detector Function with the XC6403/04 Series>

The series' detector function monitors the voltage divided by resistors R3 & R4 which are connected to the V_{ROUT} pin or the V_{IN} pin or the V_{SEN} pin, as well as monitoring the voltage of the internal reference voltage source via the comparator. The V_{DSEN} pin has options (please refer to the Selection Guide, item 4). A 'High' or 'Low' signal level can be output from the V_{DOUT} pin when the V_D pin voltage level goes below the detect voltage. The V_D output logic has options (please refer to the Selection Guide, item 5). As V_{DOUT} is an open-drain N-channel output, a pull-up resistor of about 220kΩ is needed to achieve a voltage output. Because of hysteresis at the detector function, output at the V_{DOUT} pin will invert when the detect voltage level increases above the release voltage (105% of the detect voltage). Even when the XC6403/04A, B, C, series are in stand-by mode, the voltage detector function operates and the output voltage at V_{DOUT} will output according to the voltage level at V_{DSENSE} voltage.

For the XC6403/04A, B, C types, in stand-by, if a voltage of the recovery voltage is present at the V_{ROUT} pin (from another power source), the V_{DOUT} pin will be high impedance mode, and the pull up voltage will be output at V_{DOUT}. By connecting the C_{delay} pin to a capacitor (C_d), the XC6403/04F series can apply a delay time to V_{DOUT} voltage when releasing voltage. The delay time can be calculated from the internal resistance, R_{delay} (2MΩ fixed) and the value of C_d as per the following equation.

$$\text{Delay Time} = C_{\text{delay}} \times R_{\text{delay}} \times 0.7$$

Delay Time R_{delay} standard : 1.0 ~ 3.5MΩ TYP : 2.0MΩ

C _{delay}	DELAY TIME (TYP.)	DELAY TIME (TYP.)
0.01 μF	14 msec	7.0 ~ 24.5 msec
0.022 μF	30.8 msec	15.4 ~ 53.9 msec
0.047 μF	65.8 msec	32.9 ~ 115.15 msec
0.1 μF	140 msec	70.0 ~ 245.0 msec
0.22 μF	308 msec	154.0 ~ 539.0 msec
0.47 μF	658 msec	329.0 ~ 1151.5 msec
1 μF	1400 msec	700.0 ~ 2450.0 msec

<Low ESR Capacitors>

With the XC6403/04 series regulator, a stable output voltage is achievable even if low ESR capacitors are used, as a phase compensation circuit is built-in to the regulator. In order to ensure the effectiveness of the phase compensation, we suggest that an output capacitor (C_L) be connected as close as possible, between the output pin (V_{ROUT}) and the V_{SS} pin. Please use an output capacitor (C_L) with a capacitance, based on the chart below. We also suggest an input capacitor (C_{IN}) of 1 μF : this should be connected between V_{IN} and V_{SS} in order to stabilize input power source.

Output Capacitor

V _{ROUT}	0.9 ~ 1.2V	1.3 ~ 1.7V	1.8 ~
C _L	More Than 4.7 μF	More Than 2.2 μF	More Than 1.0 μF

<Current Limiter, Short-Circuit Protection>

The XC6403/04 series regulator offers a combination of current limit and circuit protection by means of a built-in fixed current limiter circuit and a foldback circuit. When the load current reaches the current limit level, the fixed current limiter circuit operates and output voltage drops. As a result of this drop in output voltage, the foldback circuit operates, the output voltage drops further and output current decreases. When the output pin is shorted, a current of about 50mA flows.

■ OPERATIONAL EXPLANATION (Continued)

<EN / CE Pin>

The IC's internal regulator circuitry can be shut down via the signal from the EN pin with the XC6403/04A, B, C series. In shutdown mode, output at the V_{ROUT} pin will be pulled down to the V_{SS} level via R1 & R2. The whole IC's circuitry can be shut down via CE pin with the XC6403/04D series and power consumption can be reduced to around 0 μA (TYP.). While the voltage detector is in shutdown mode, the voltage detector output is in a post-detection state. When choosing Detect L, input current can be set by using the following formula.

$$\text{Input Current} = V_{IN} \text{ voltage} / \text{Pull-Up Resistance}$$

In stand-by mode, the above input current can be reduced by connecting a pull-up resistor between V_{ROUT} and V_{DOUT}.

Note that as the XC6403/04 *E to K types of the XC6404A to D series are 'High Active / No Pull-Down' and XC6403/04 *R to U types of the XC6404A to D series are 'Low Active / No Pull-Up', operations will become unstable with the CE pin open (See the chart below).

SERIES	EN/CE INPUT LOGIC
XC6403/04 * A ~ D	High Active with Pull-Down
XC6403/04 * E ~ K	High Active with No Pull-Down
XC6403/04 * L ~ P	Low Active with Pull-Up
XC6403/04 * R ~ U	Low Active with No Pull-Up

(* A ~ D Series)

We suggest that you use this IC with either a V_{IN} voltage or a V_{SS} voltage input at the EN or CE pin. If this IC is used with the correct specifications for the EN or CE pin, the IC will operate normally. However, supply current may increase as a result of through current in the IC's internal circuitry if a voltage other than V_{IN} or V_{SS} is applied.

<Toggle Operation>

The XC6403/04 A and B series have a built-in toggle ON/OFF switch which repeats an on/off operation via the EN pin's leading edge signal when the EN logic is Active HIGH, and via the EN pin's falling edge signal when the EN logic is Active LOW (Please also refer the figure below). The EN input signal duration should be over 500nsec. If the EN input signal is less than 500nsec, it is possible that the circuit fails to respond and the toggle function does not operate. To operate the toggle function properly when the EN pin voltage noise is large, a RC filter should be used to reduce the noise in the signal to the EN pin. In the case where input delay time is required, it is possible to set the time constant by connecting an RC network to the EN pin.

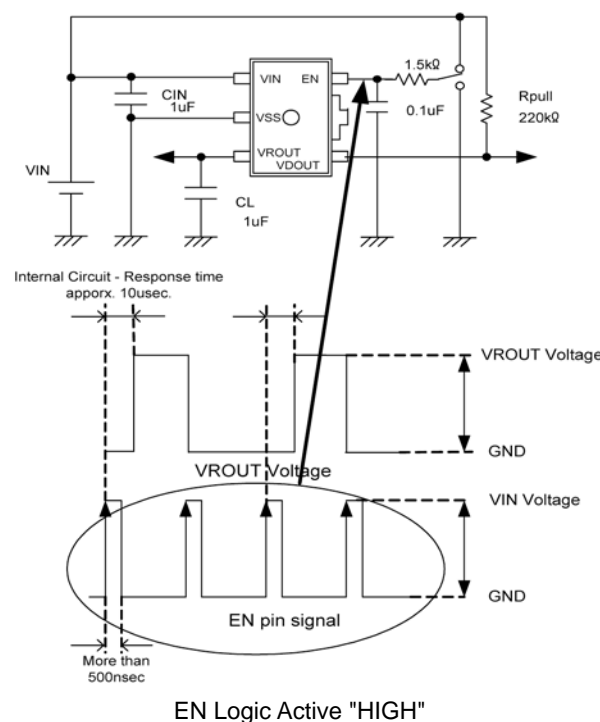

OPERATIONAL EXPLANATION (Continued)

<Toggle Operation> (Continued)

For the XC6403/04B series, there are two types of toggle selection; one is a T-type flip-flop (T-FF) used for toggle operation which can be reset internally by a signal directly from the voltage detector (V_{IN} Sense type only. See also the Selection Guide). The other type is where the reset is applied internally through a one shot pulse circuit

(V_{IN} , V_{ROUT} type only. See also the Selection Guide). The type, which applies the reset directly via the signal from the voltage detector function, applies the voltage detector comparator's output signal (reset signal) to the reset of T-FF reset, and turns the VR output OFF when the input voltage decreases below the detect voltage due to battery consumption, etc.. In order to return the VR output, apply a voltage larger than the release voltage to V_{IN} and input a toggle signal to the T-FF. In the case where input voltage is below the release voltage, the VR output does not return even though the toggle signal is input into the T-FF.

The type which applies the reset signal to the T-FF internally via a one-shot pulse circuit changes the voltage detector comparator output signal to a one-shot signal internally. Like the type which applies the reset directly via the signal from voltage detector function, this type also applies the reset to the T-FF and sets the VR output to OFF when the input voltage (V_{IN} Sense type) and output voltage (V_{ROUT} Sense type) drop below the detect voltage level. This type can return the VR output by inputting a toggle signal, even when the Sense pin voltage (V_{IN} or V_{ROUT} pin voltage) is below the release voltage. Please refer to the block diagram below and the timing chart on the following page. Please choose the option suitable to the application.

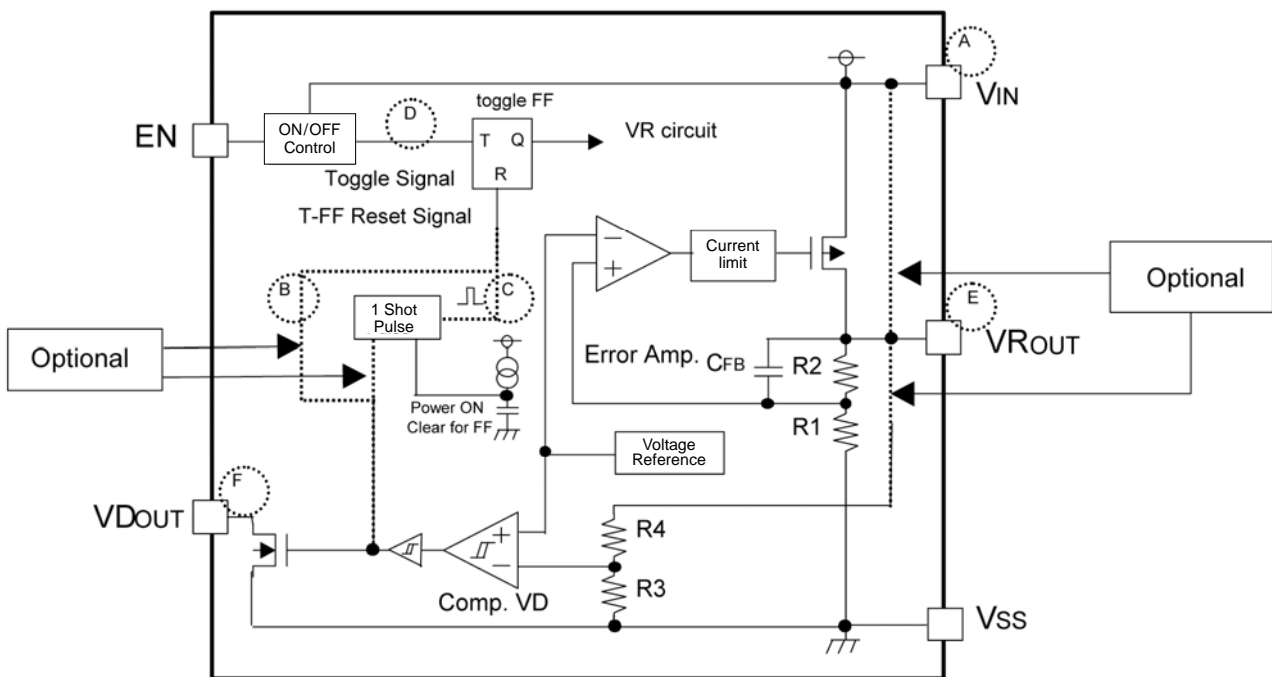

Block Diagram for XC6403/04B series Timing Chart

TIMING CHART

XC6403/04B Series

- Using the VD output level signal as the reset signal of T-FF (VD Sense = VIN PIN)

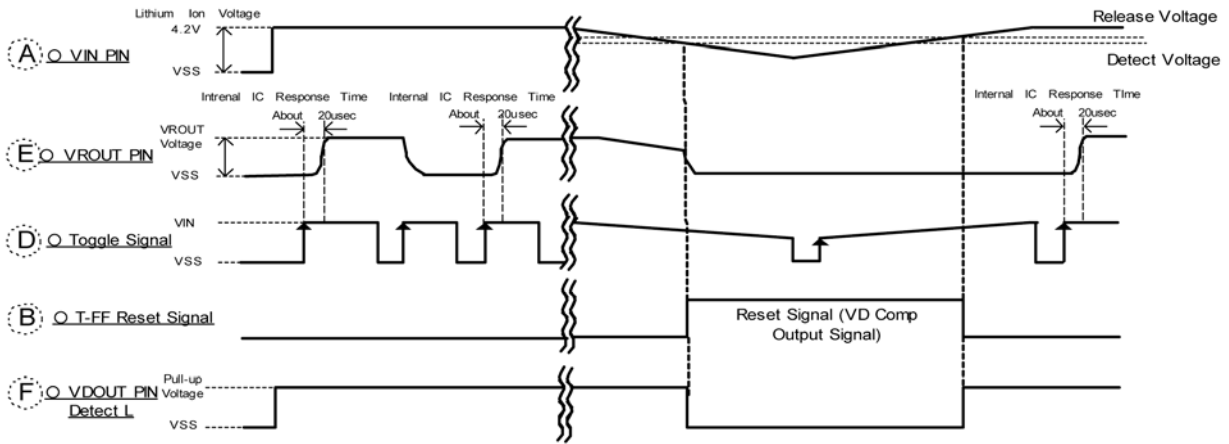

- Changing the VD output level signal into a one shot pulse to use T-FF as the reset signal (VD Sense = VIN PIN)

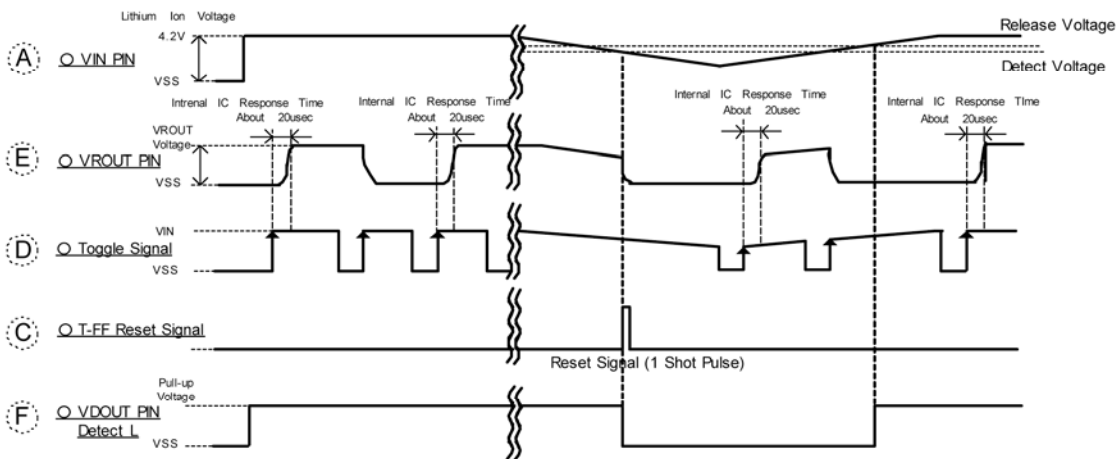

- Changing the VD output level signal into a one shot pulse to use T-FF as the reset signal (VD Sense = VROUT PIN)

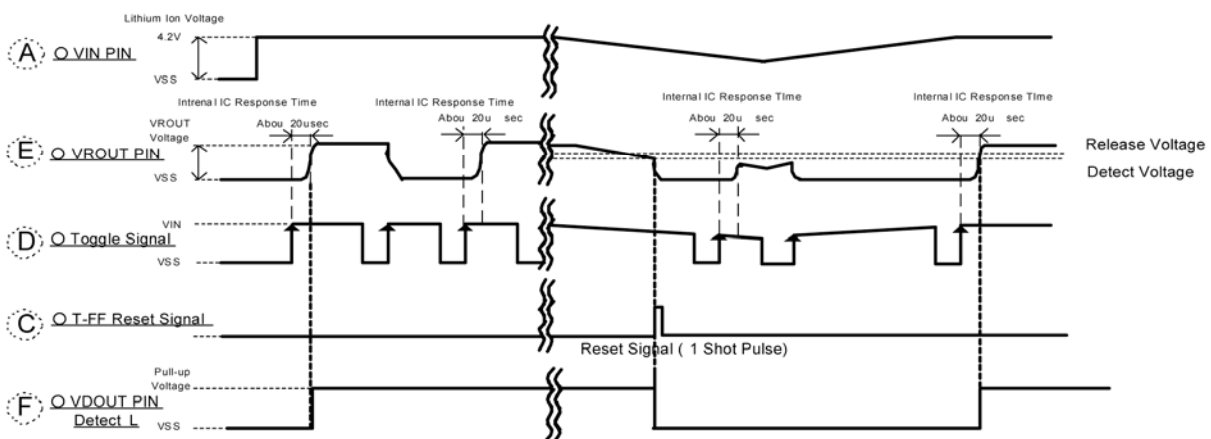

The circled letters correspond to those shown on the block diagrams.

■ NOTES ON USE

1. Please use this IC within the stated absolute maximum ratings. The IC is liable to malfunction should the ratings be exceeded.
2. Where wiring impedance is high, operations may become unstable due to noise and/or phase lag depending on output current. Please strengthen V_{IN} and V_{SS} wiring in particular.
3. Please wire the input capacitor (C_{IN}) and the output capacitor (C_L) as close to the IC as possible.
Should rapid input fluctuation or load fluctuation occur, please increase the capacitor value such as C_{IN} or C_L to stabilize the operation.

TYPICAL PERFORMANCE CHARACTERISTICS

●XC6403 Series

(1) VR Output Voltage vs. VR Output Current

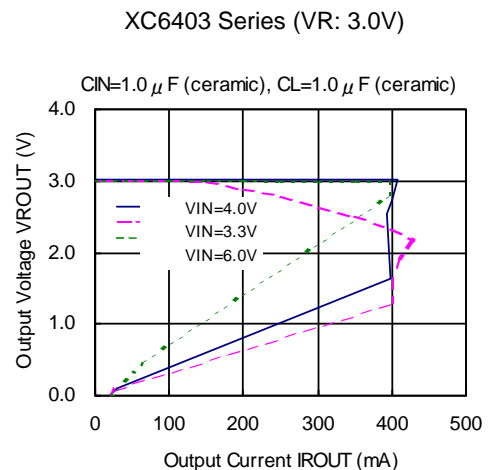
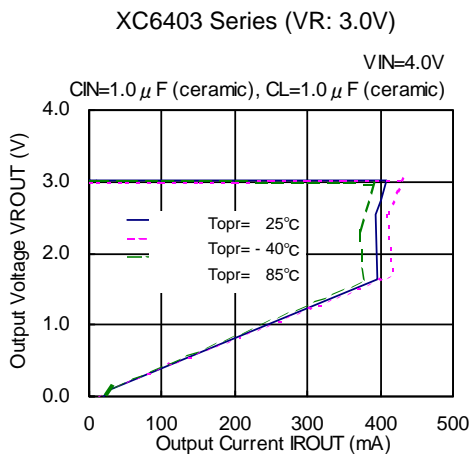
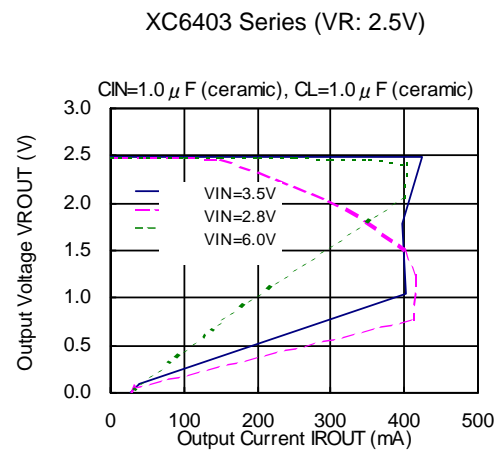
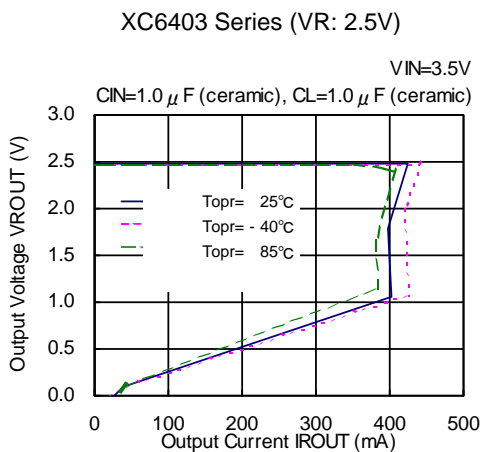
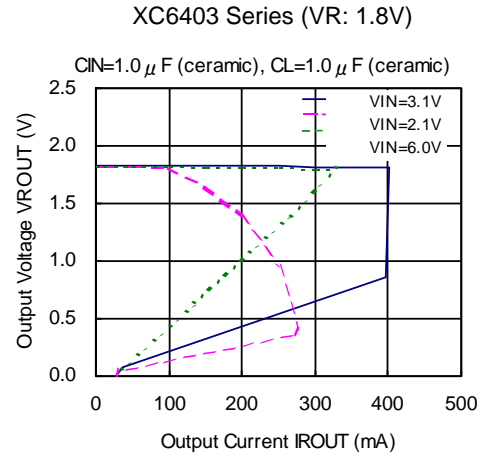
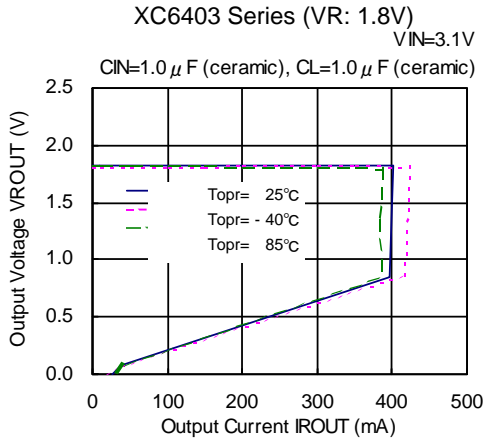

TYPICAL PERFORMANCE CHARACTERISTICS (Continued)

● XC6403 Series (Continued)

(1) VR Output Voltage vs. VR Output Current (Continued)

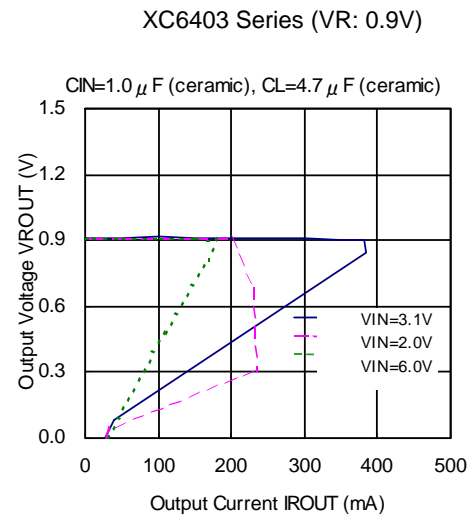
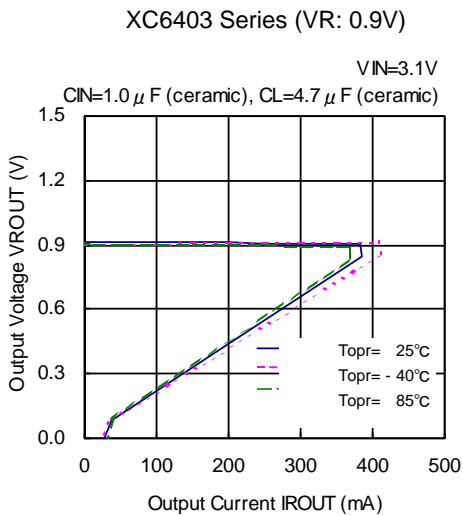
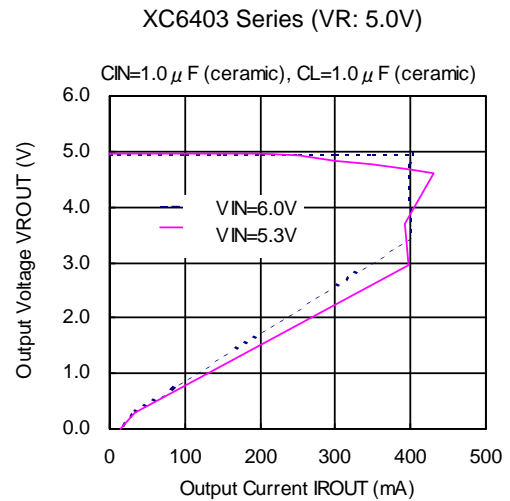
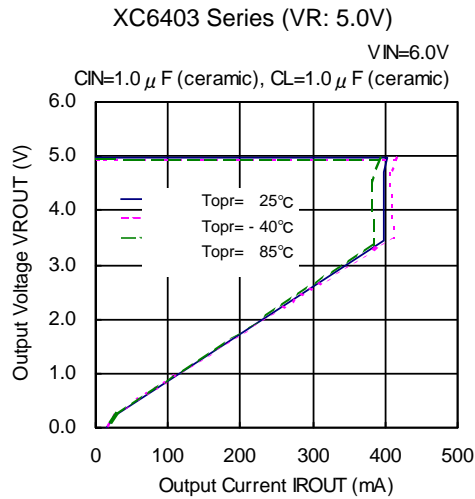

■ TYPICAL PERFORMANCE CHARACTERISTICS (Continued)

● XC6404 Series

(1) VR Output Voltage vs. VR Output Current

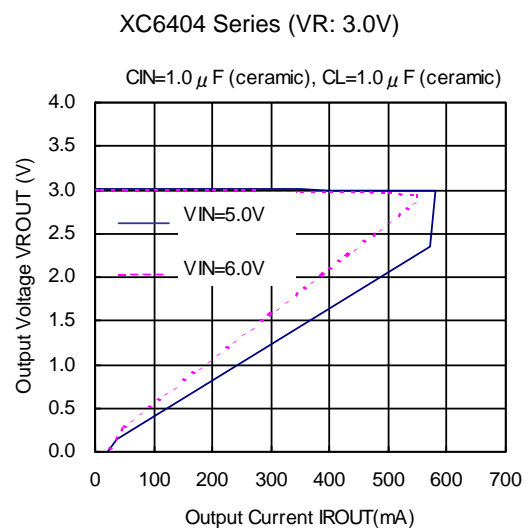
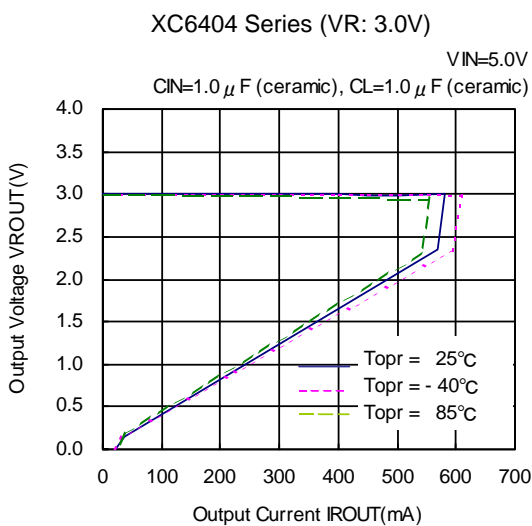
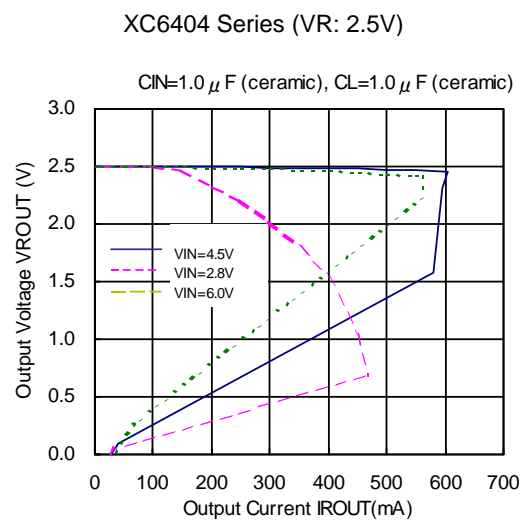
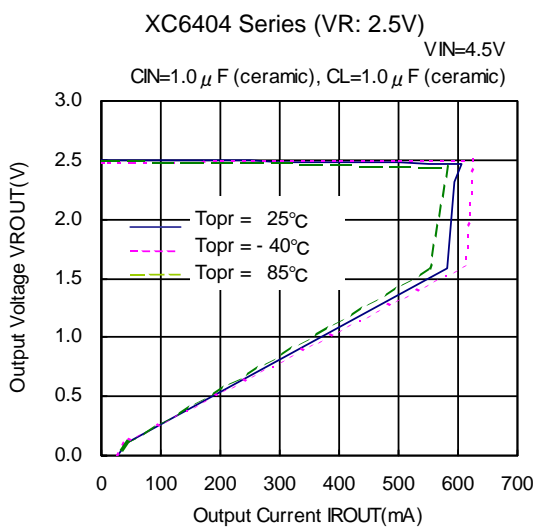
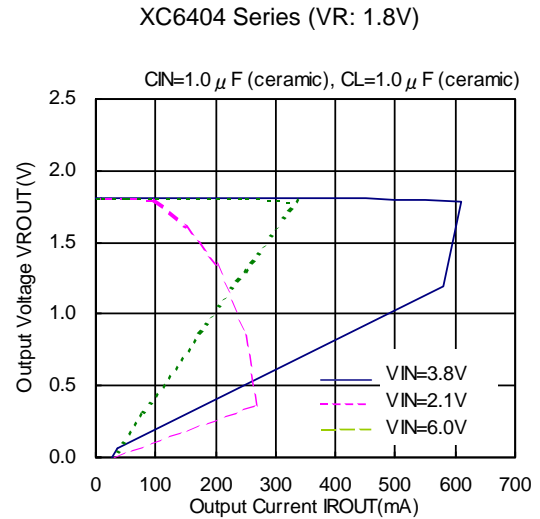
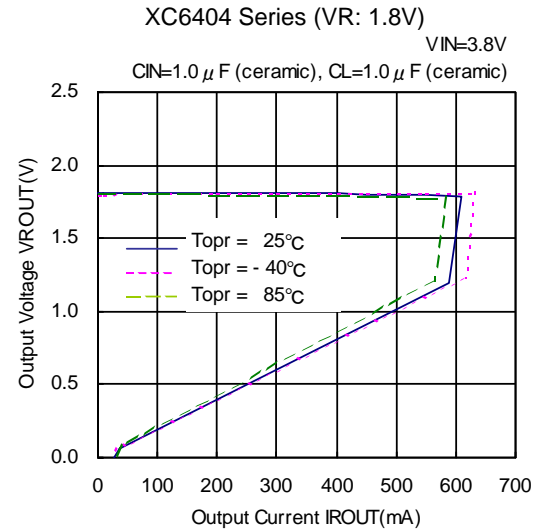

TYPICAL PERFORMANCE CHARACTERISTICS (Continued)

XC6404 Series (Continued)

(1) VR Output Voltage vs. VR Output Current (Continued)

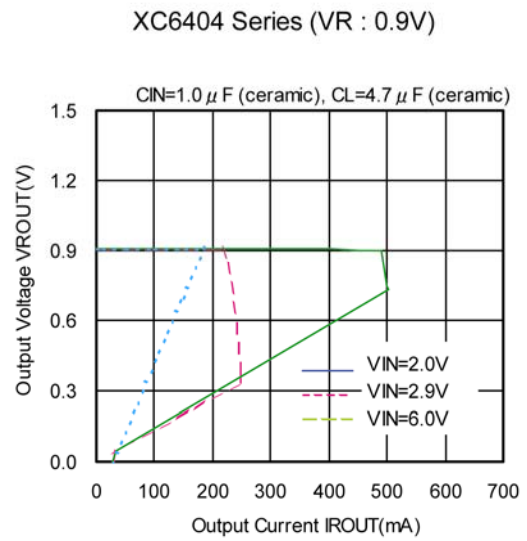
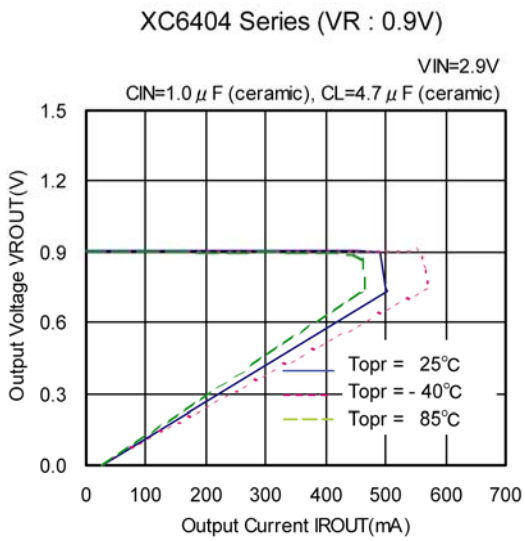
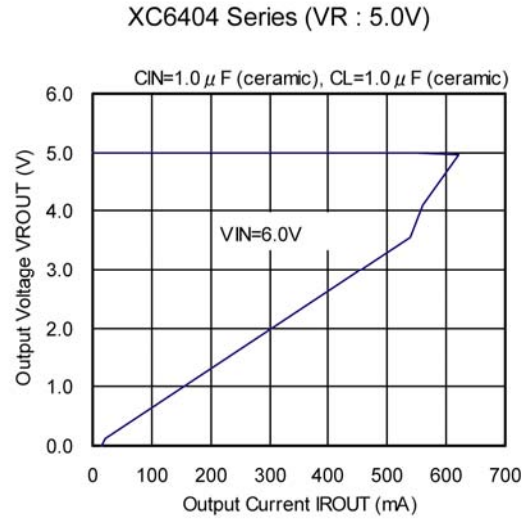
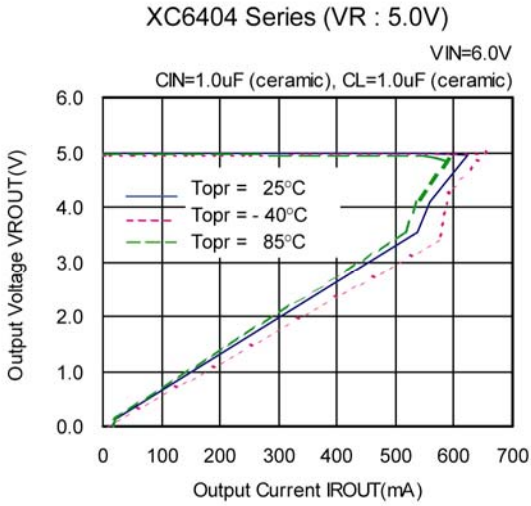

■ TYPICAL PERFORMANCE CHARACTERISTICS (Continued)

● XC6403/04 Series

(2) VR Output Voltage vs. Input Voltage

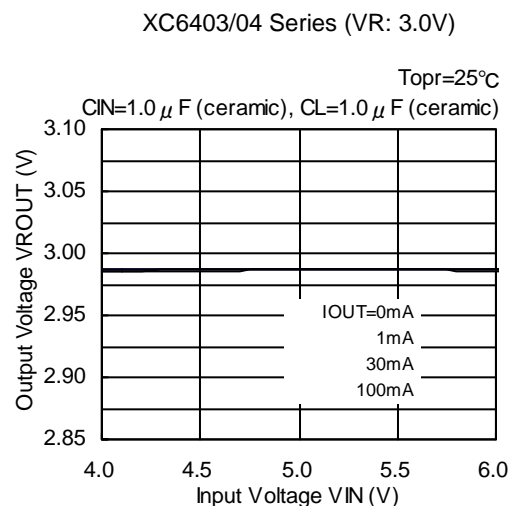
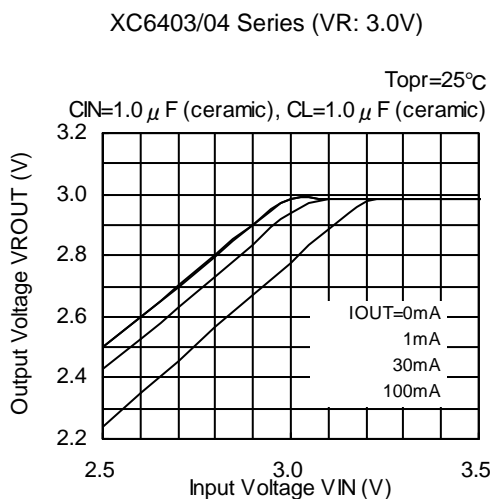
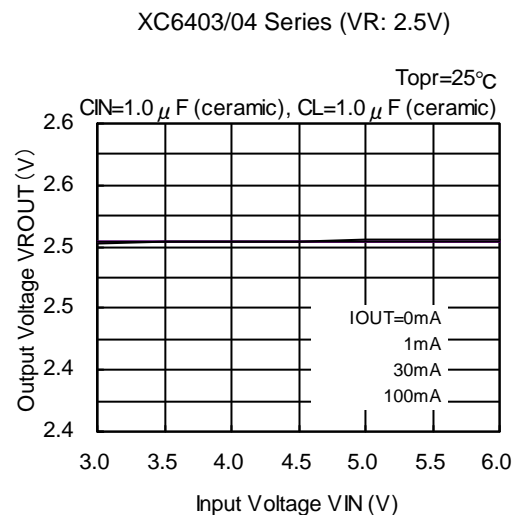
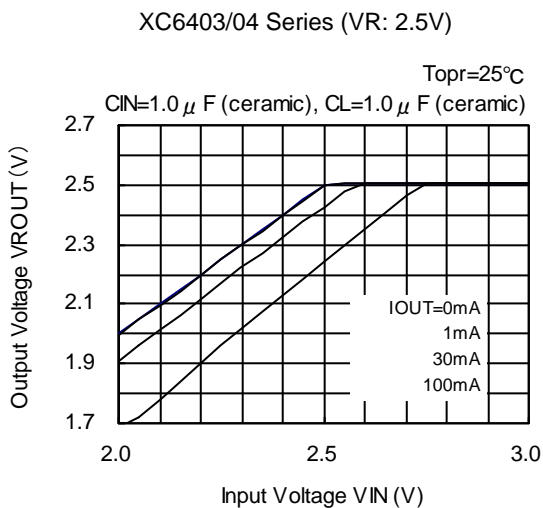
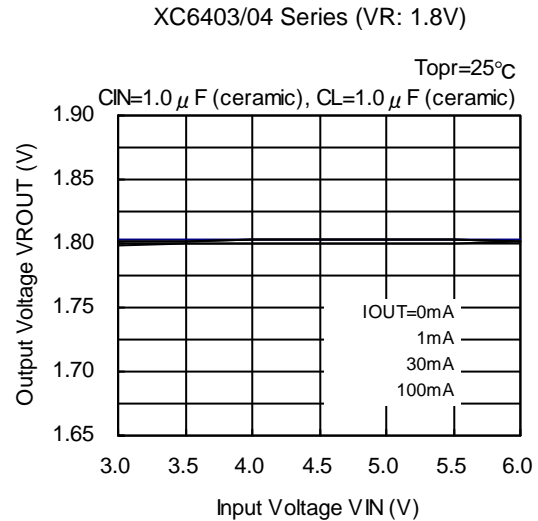
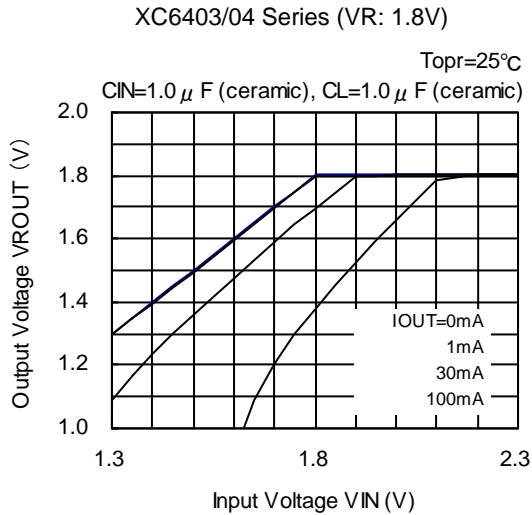

TYPICAL PERFORMANCE CHARACTERISTICS (Continued)

●XC6403/04 Series (Continued)

(2) VR Output Voltage vs. Input Voltage (Continued)

XC6403/04 Series (VR: 5.0V)

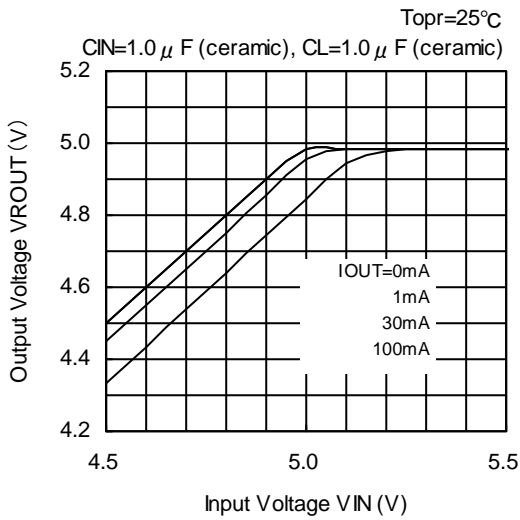

XC6403/04 Series (VR: 5.0V)

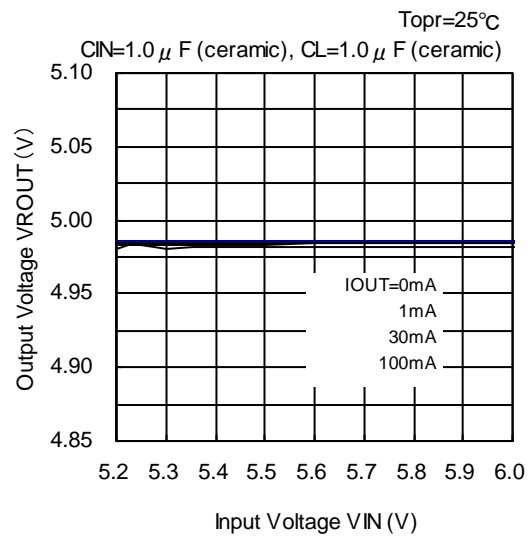

XC6403/04 Series (VR: 0.9V)

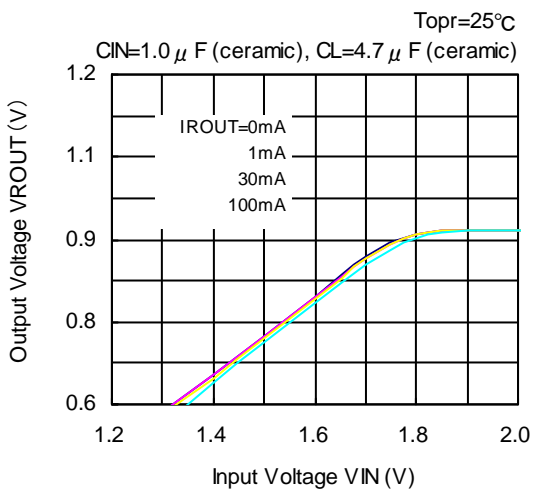

XC6403/04 Series (VR: 0.9V)

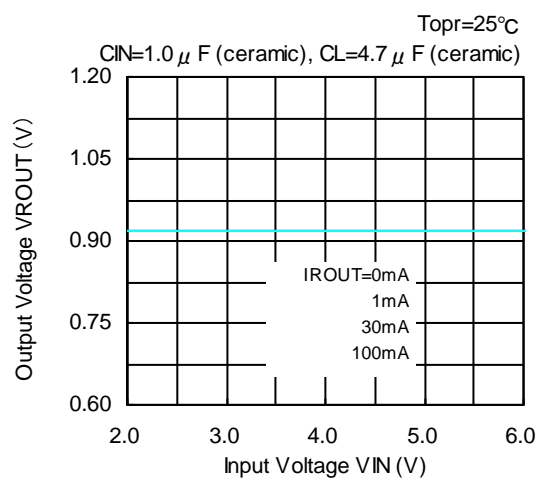

TYPICAL PERFORMANCE CHARACTERISTICS (Continued)

●XC6403/04 Series (Continued)

(3) Dropout Voltage vs. VR Output Current

XC6403/04 Series (VR: 1.8V)

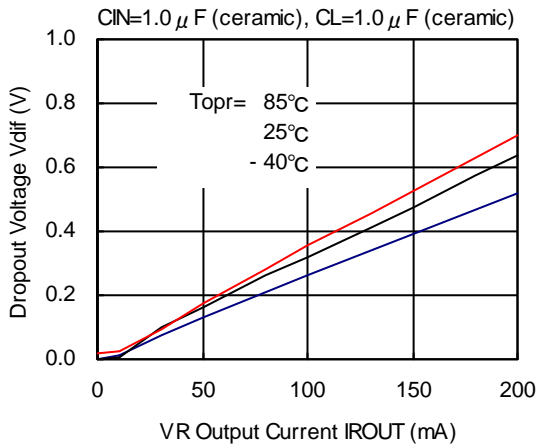

XC6403/04 Series (VR: 2.5V)

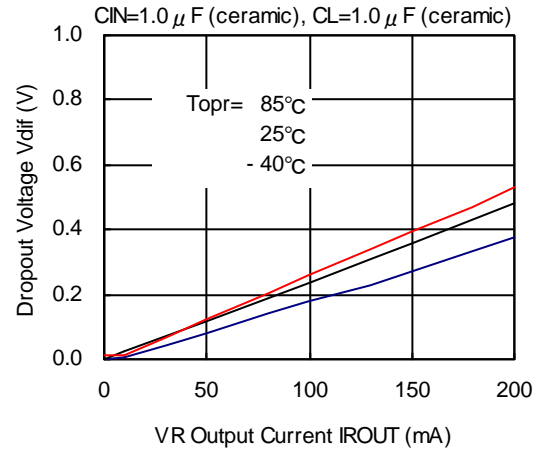

XC6403/04 Series (VR: 3.0V)

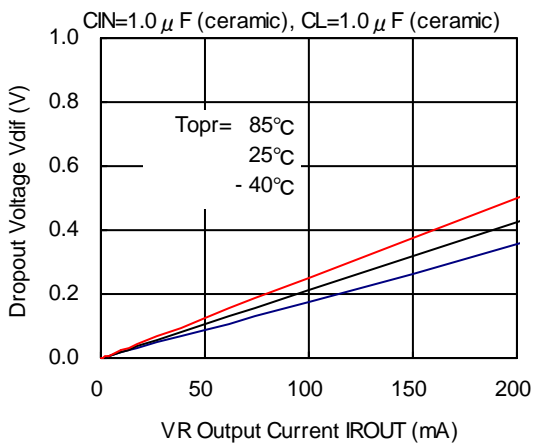

XC6403/04 Series (VR: 5.0V)

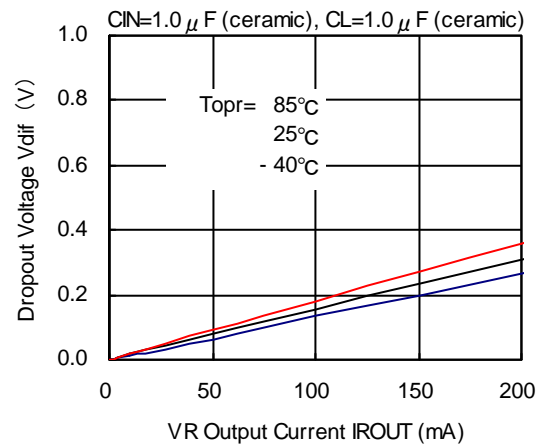

XC6403/04 Series (VR: 0.9V)

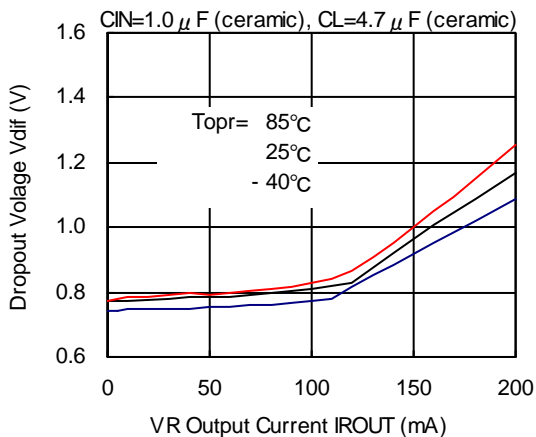

TYPICAL PERFORMANCE CHARACTERISTICS (Continued)

●XC6403/04 Series (Continued)

(4) Supply Current vs. Input Voltage

XC6403/04 Series (VR: 1.8V)

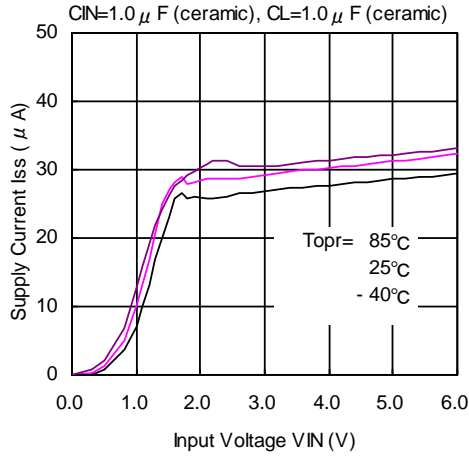

XC6403/04 Series (VR: 2.5V)

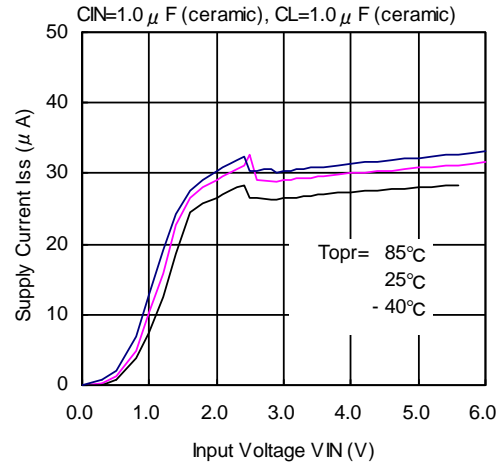

XC6403/04 Series (VR: 3.0V)

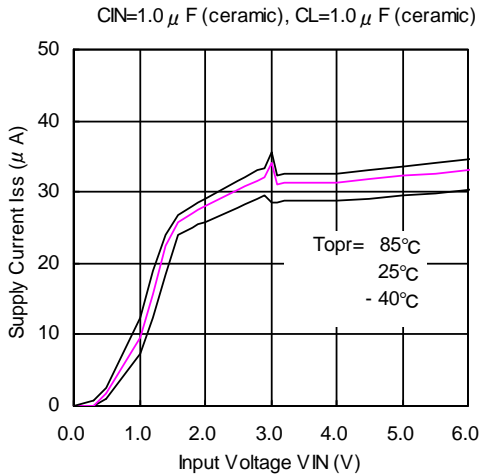

XC6403/04 Series (VR: 5.0V)

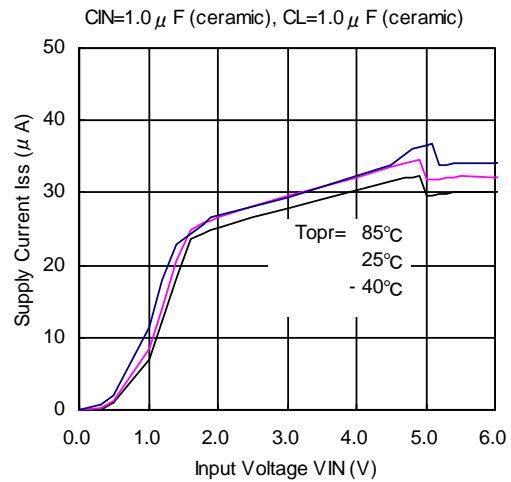

XC6403/04 Series (VR: 0.9V)

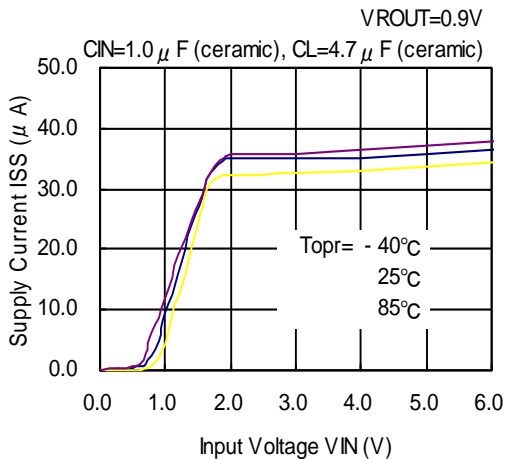

■ TYPICAL PERFORMANCE CHARACTERISTICS (Continued)

● XC6403/04 Series (Continued)

(5) VR Output Voltage vs. Ambient Temperature

XC6403/04 Series (VR: 1.8V)

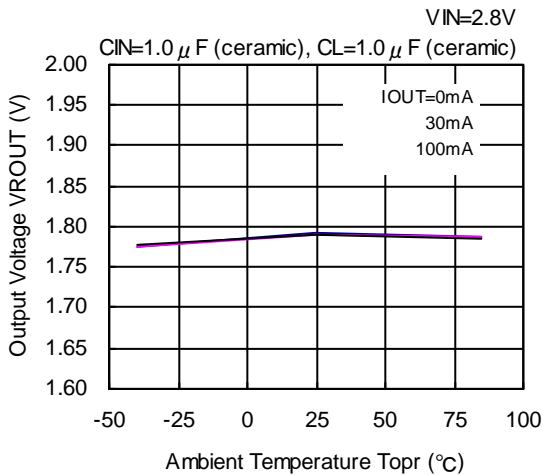

XC6403/04 Series (VR: 2.5V)

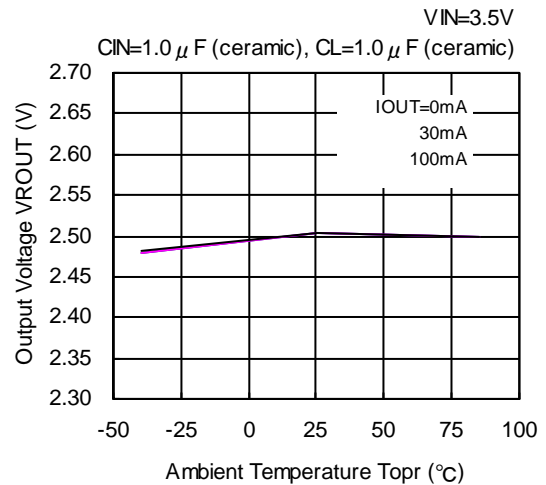

XC6403/04 Series (VR: 3.0V)

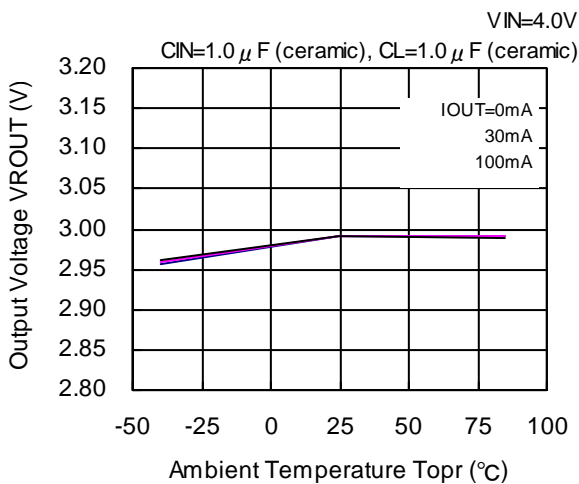

XC6403/04 Series (VR: 5.0V)

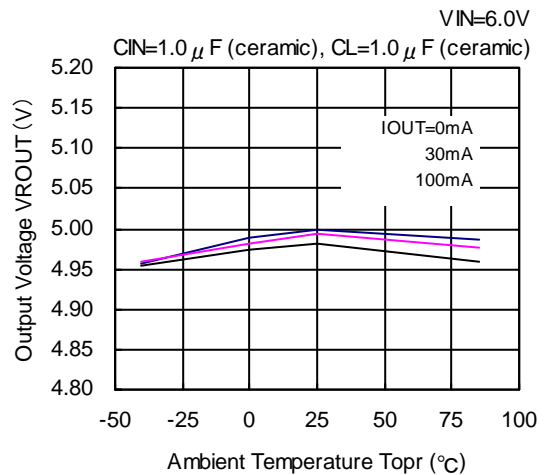

XC6403/04 Series (VR: 0.9V)

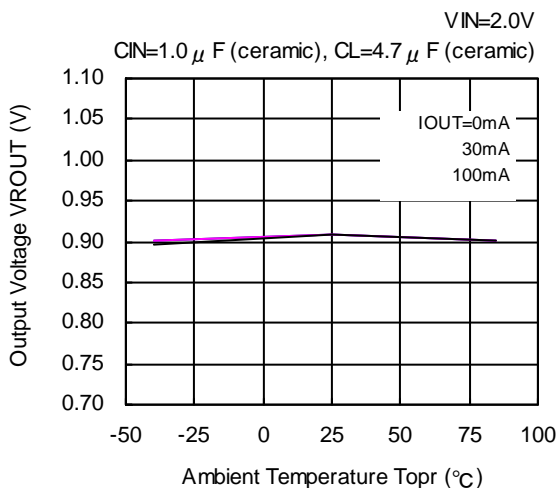

TYPICAL PERFORMANCE CHARACTERISTICS (Continued)

●XC6403/04 Series (Continued)

(6) Supply Current vs. Ambient Temperature

XC6403/04 Series (VR: 1.8V)

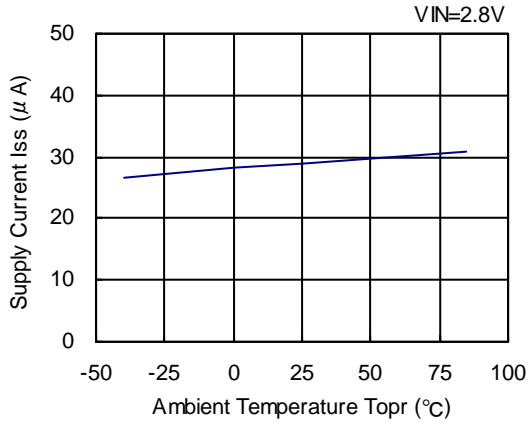

XC6403/04 Series (VR: 2.5V)

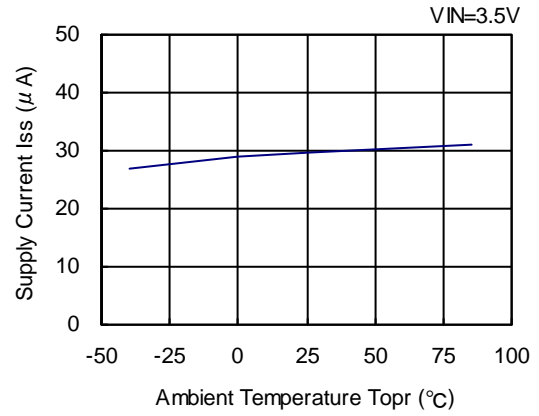

XC6403/04 Series (VR: 3.0V)

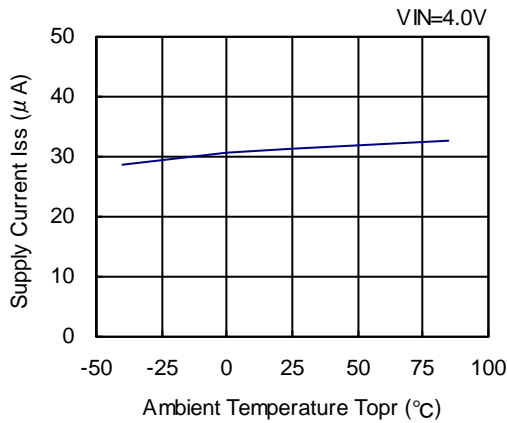

XC6403/04 Series (VR: 5.0V)

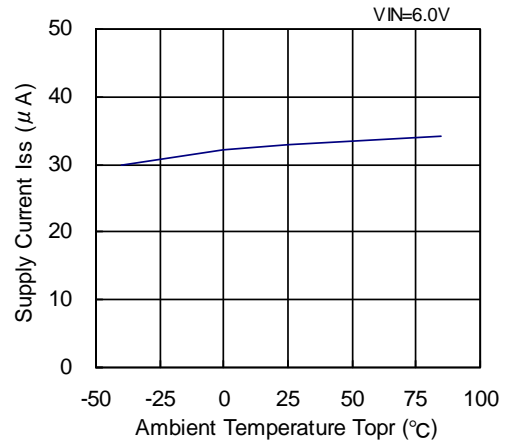

XC6403/04 Series (VR: 0.9V)

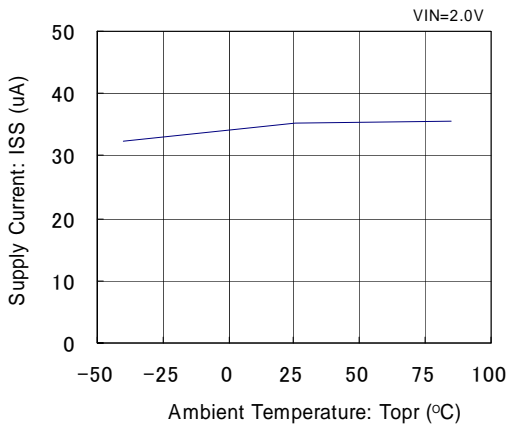

TYPICAL PERFORMANCE CHARACTERISTICS (Continued)

●XC6403/04 Series (Continued)

(7) EN/CE Threshold Voltage vs. Ambient Temperature

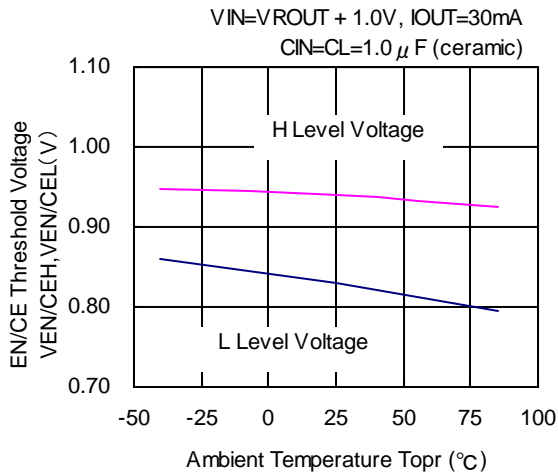

(8) Rdelay vs. Ambient Temperature

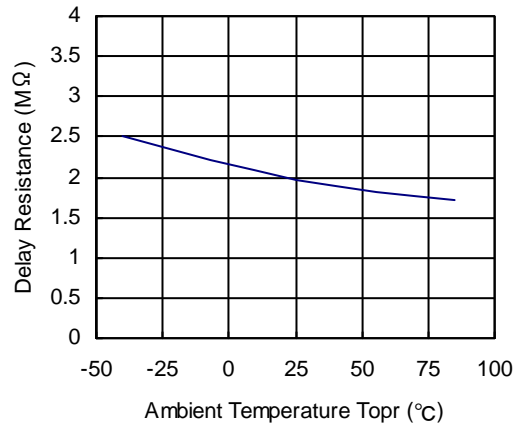

(9) Output Noise Density

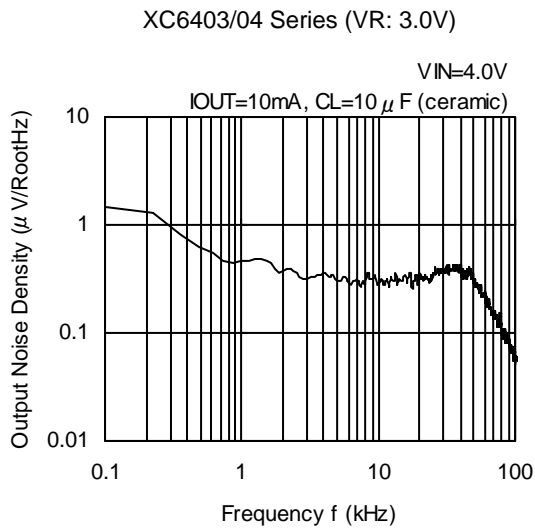

TYPICAL PERFORMANCE CHARACTERISTICS (Continued)

●XC6403/04 Series (Continued)

(10) VD Supply Current vs. Input Voltage (Only A ~ C Types)

XC6403/04 Series (VD: 2.0V)

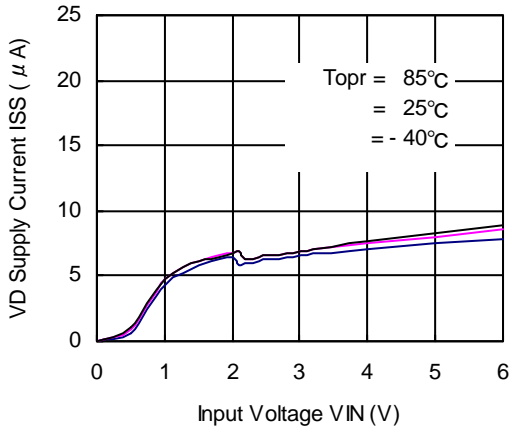

XC6403/04 Series (VD: 2.7V)

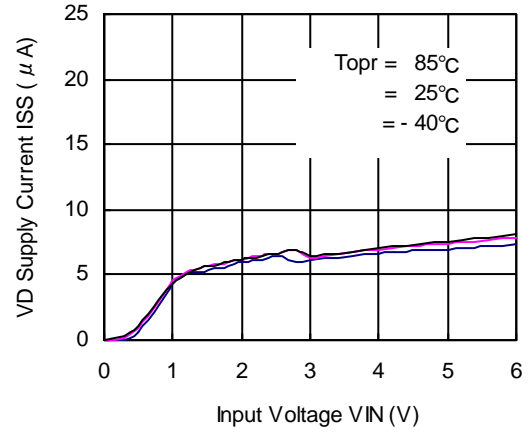

XC6403/04 Series (VD: 3.6V)

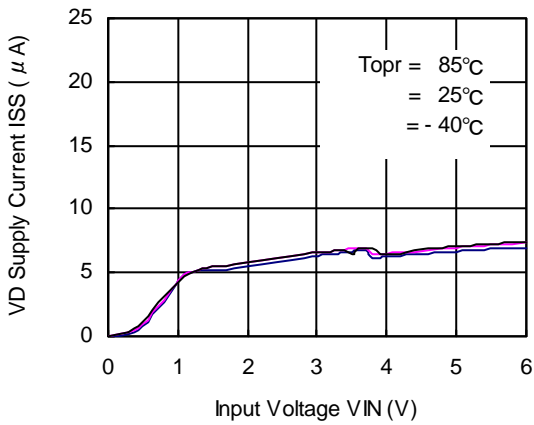

XC6403/04 Series (VD: 5.0V)

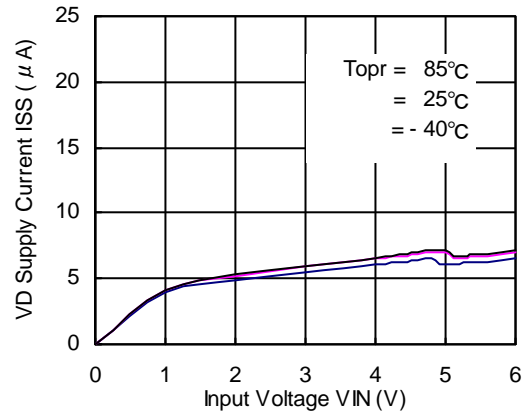

TYPICAL PERFORMANCE CHARACTERISTICS (Continued)

●XC6403/04 Series (Continued)

(11) Detect Voltage, Release Voltage vs. Ambient Temperature

XC6403/04 Series (VD: 2.0V)

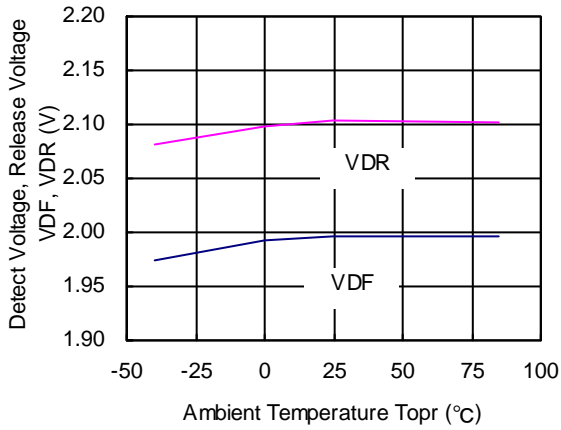

XC6403/04 Series (VD: 2.7V)

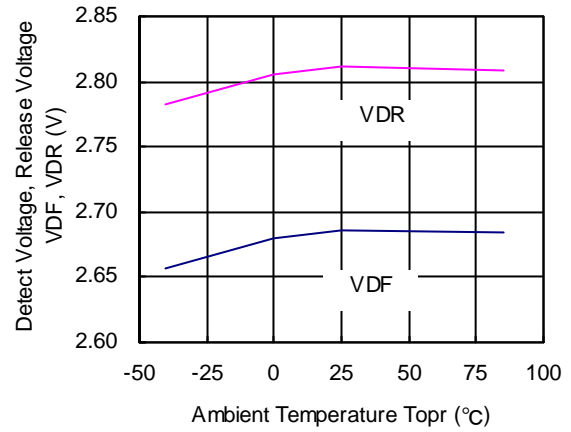

XC6403/04 Series (VD: 3.6V)

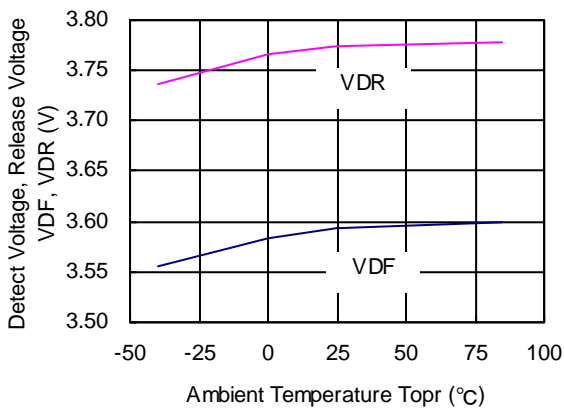

XC6403/04 Series (VD: 5.0V)

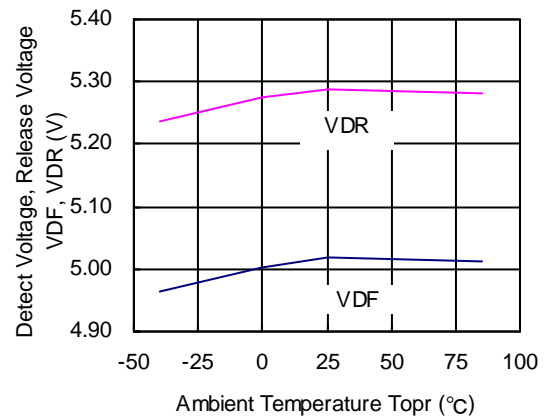

TYPICAL PERFORMANCE CHARACTERISTICS (Continued)

● XC6403/04 Series (Continued)

(12) VD N-ch Driver Output Current vs. VDS

XC6403/04 Series (VD: 2.4V)

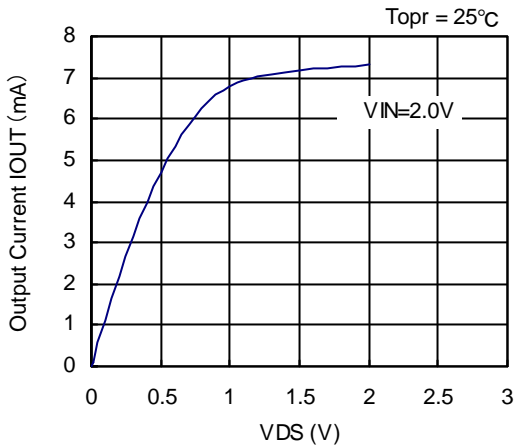

XC6403/04 Series (VD: 2.7V)

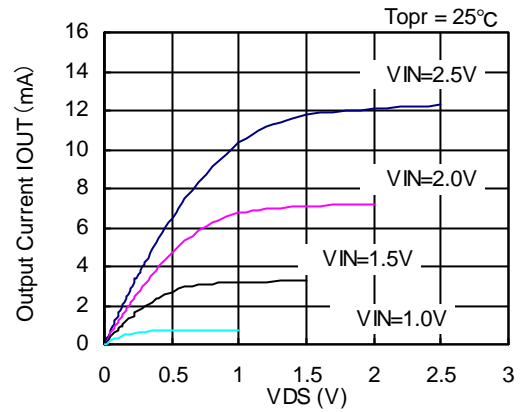

XC6403/04 Series (VD: 3.6V)

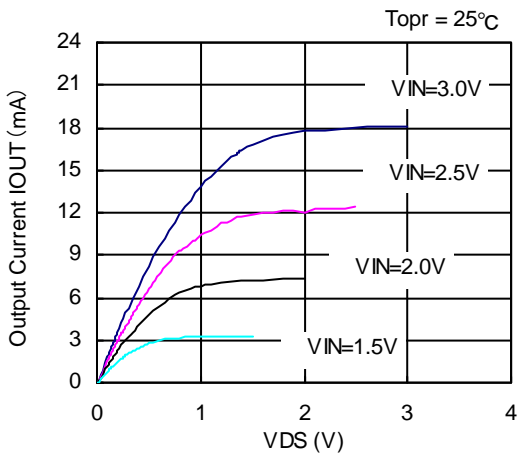

XC6403/04 Series (VD: 5.0V)

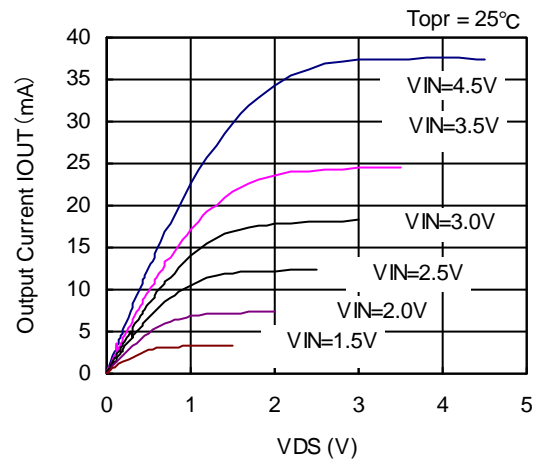

■ TYPICAL PERFORMANCE CHARACTERISTICS (Continued)

● XC6403/04 Series (Continued)

(13) VDN N-ch Driver Output Current vs. Input Voltage

XC6403/04 Series (VD: 2.0V)

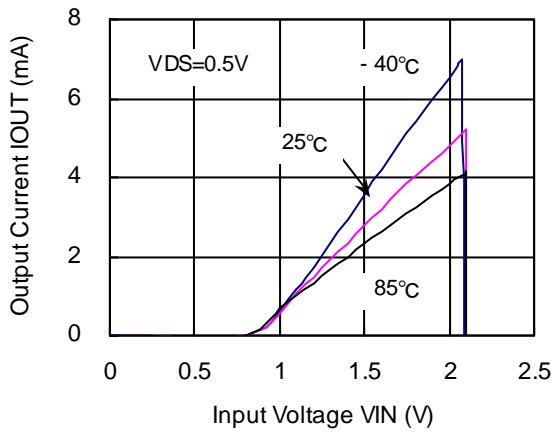

XC6403/04 Series (VD: 2.7V)

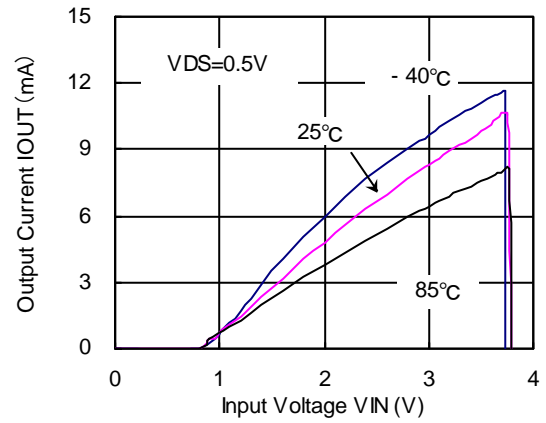

XC6403/04 Series (VD: 3.6V)

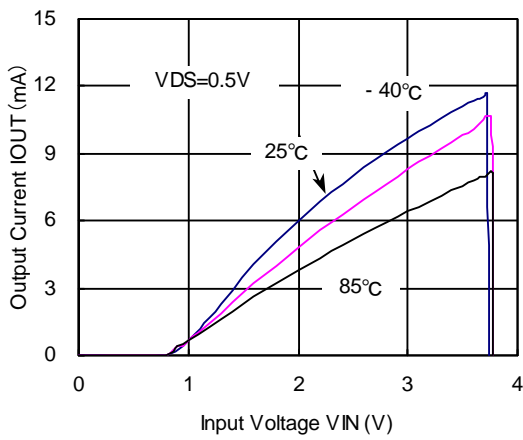

XC6403/04 Series (VD: 5.0V)

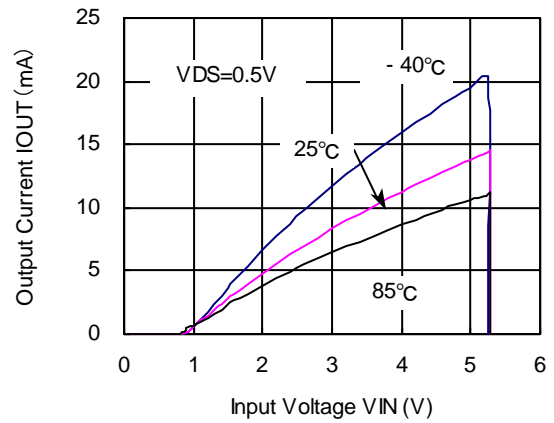

TYPICAL PERFORMANCE CHARACTERISTICS (Continued)

●XC6403/04 Series (Continued)

(14) Input Transient Response

XC6403/04 Series (VR: 1.8V)

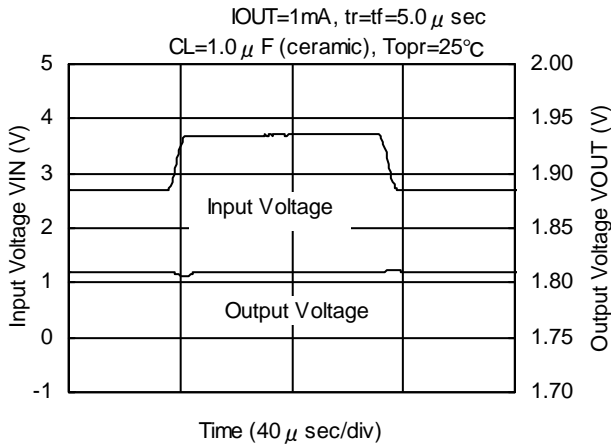

XC6403/04 Series (VR: 1.8V)

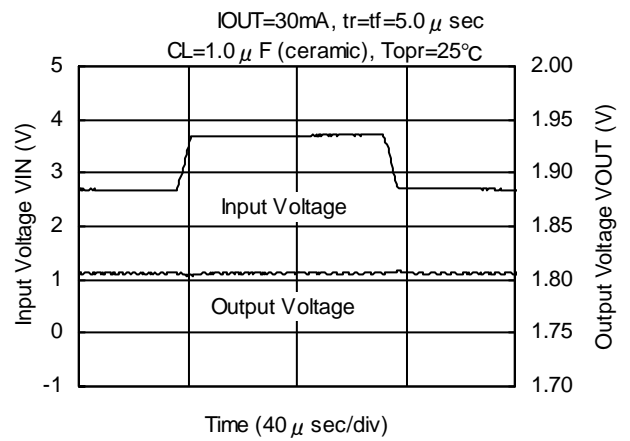

XC6403/04 Series (VR: 1.8V)

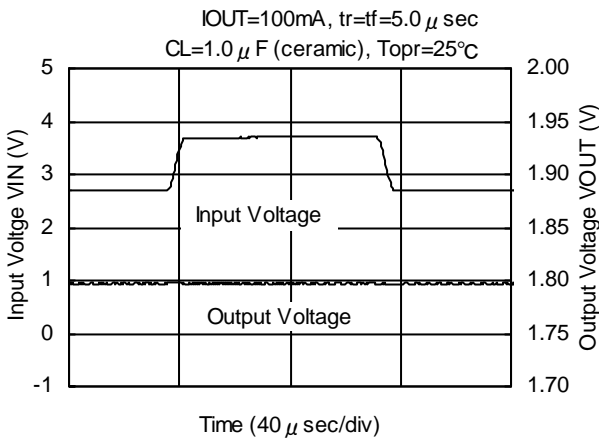

XC6403/04 Series (VR: 2.5V)

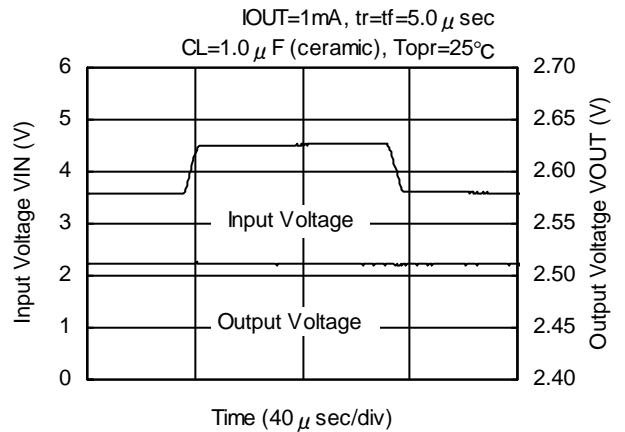

XC6403/04 Series (VR: 2.5V)

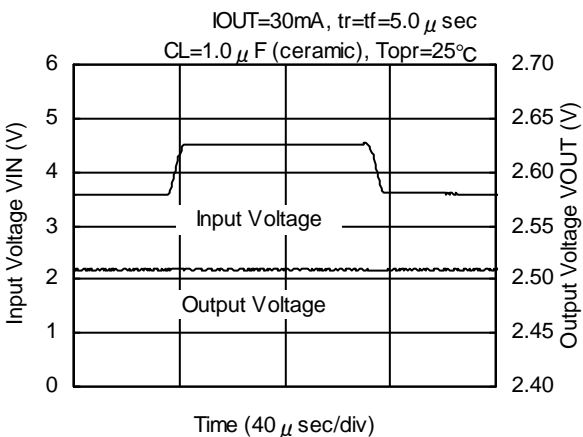

XC6403/04 Series (VR: 2.5V)

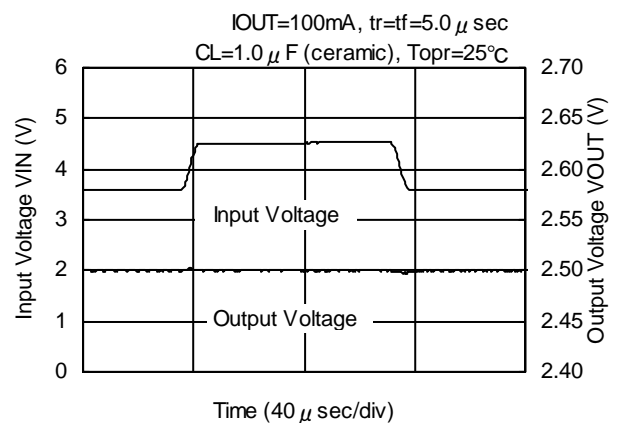

■ TYPICAL PERFORMANCE CHARACTERISTICS (Continued)

● XC6403/04 Series (Continued)

(14) Input Transient Response (Continued)

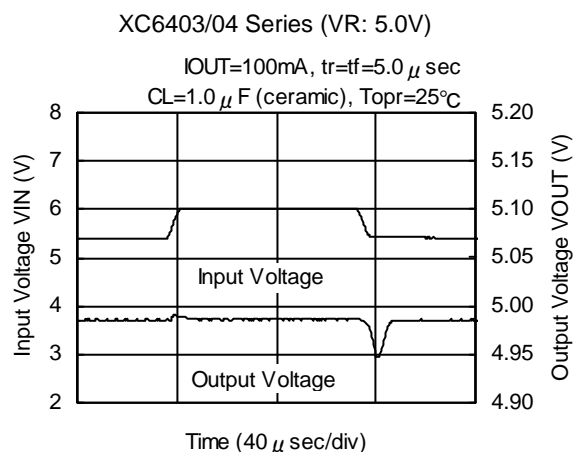
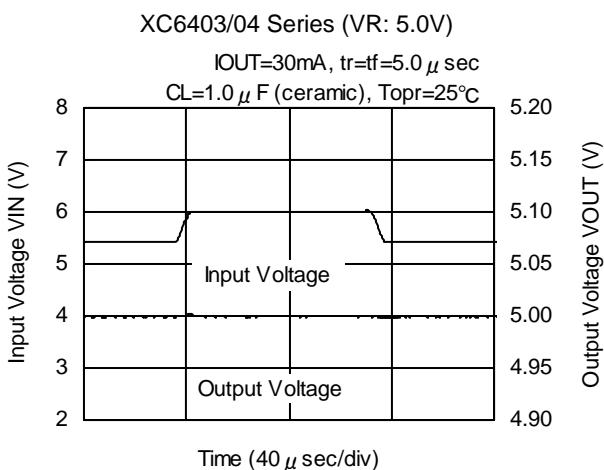
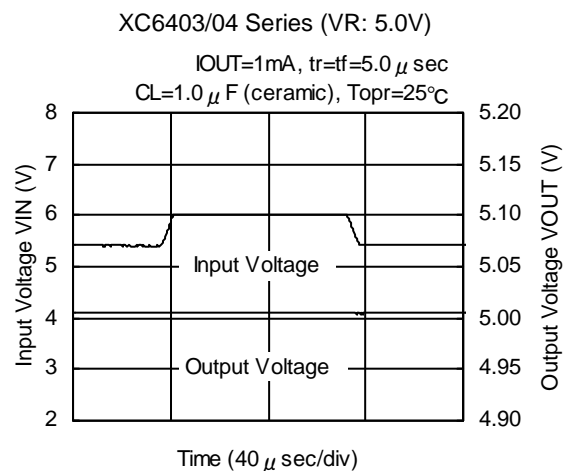
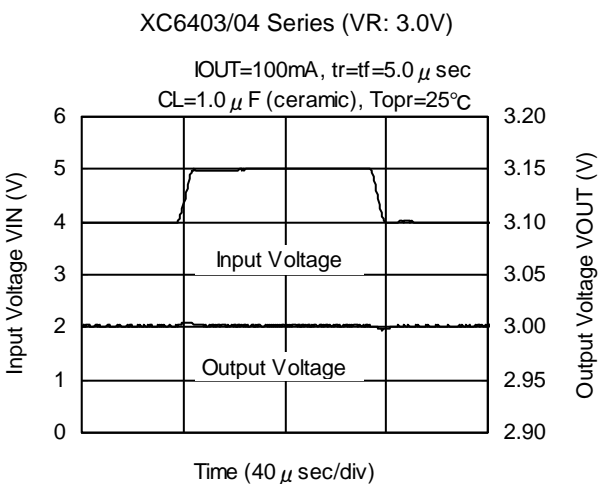
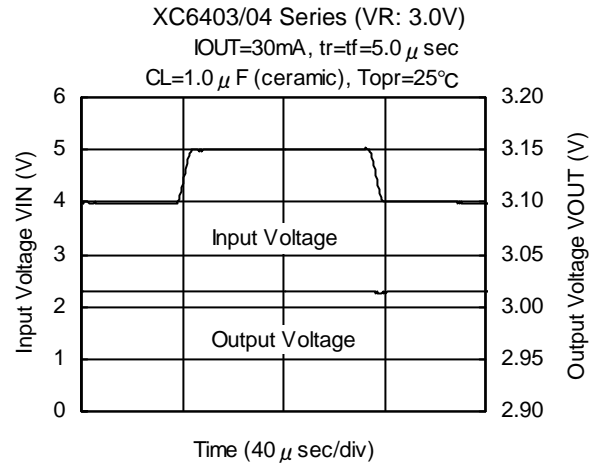
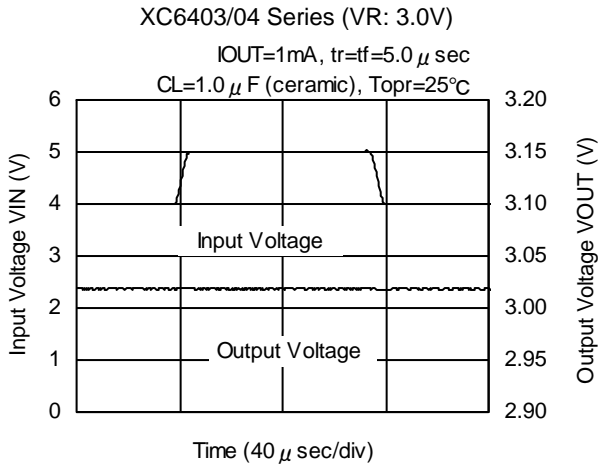

TYPICAL PERFORMANCE CHARACTERISTICS (Continued)

XC6403/04 Series (Continued)

(14) Input Transient Response (Continued)

XC6403/04 Series (VR: 0.9V)

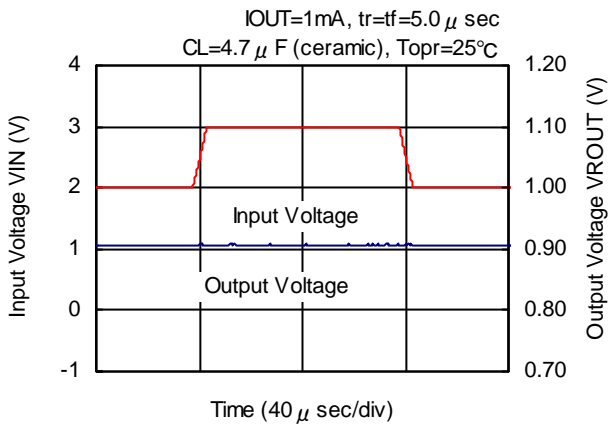

XC6403/04 Series (VR: 0.9V)

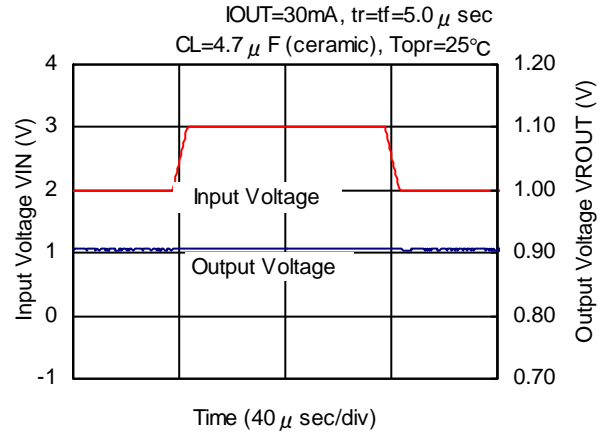

XC6403/04 Series (VR: 0.9V)

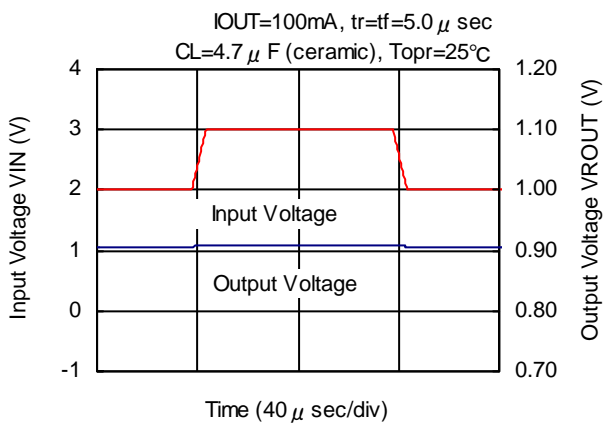

TYPICAL PERFORMANCE CHARACTERISTICS (Continued)

●XC6403/04 Series (Continued)

(15) Load Transient Response

XC6403/04 Series (VR: 1.8V)

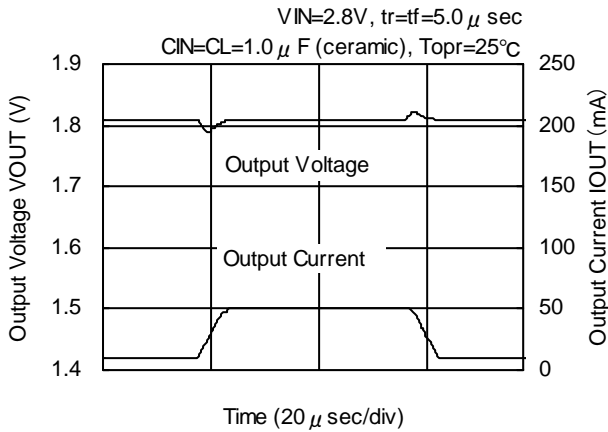

XC6403/04 Series (VR: 1.8V)

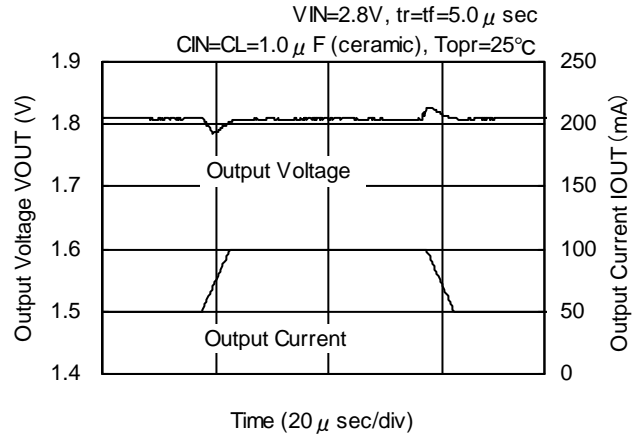

XC6403/04 Series (VR: 1.8V)

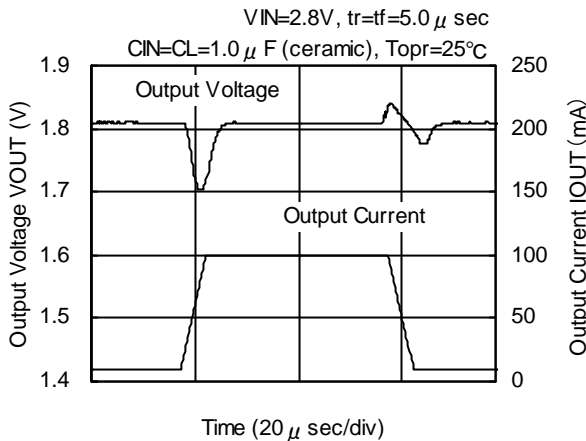

XC6403/04 Series (VR: 2.5V)

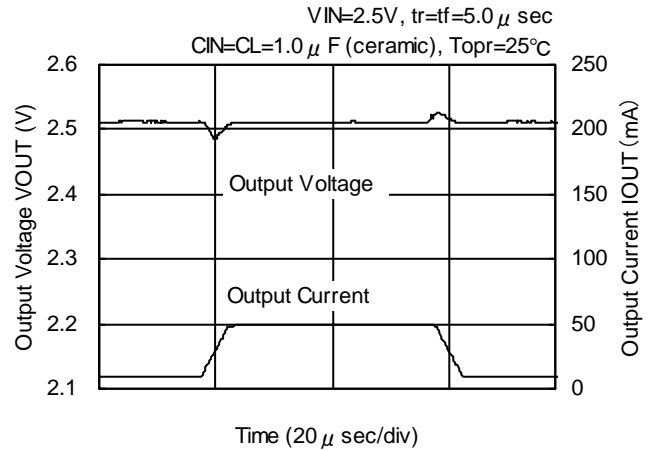

XC6403/04 Series (VR: 2.5V)

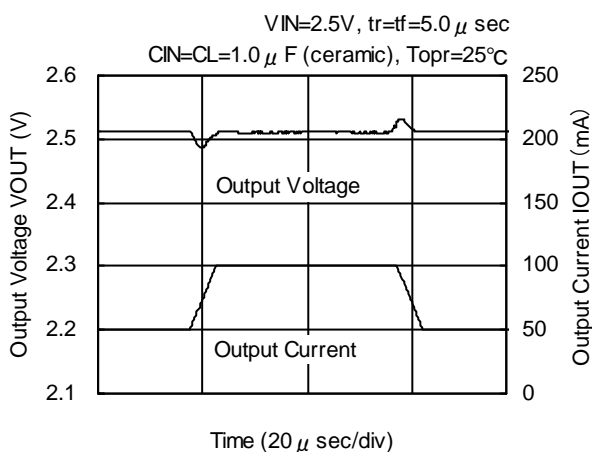

XC6403/04 Series (VR: 2.5V)

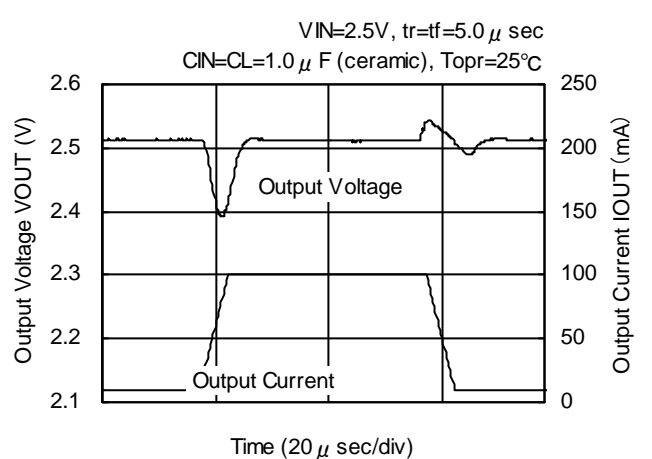

TYPICAL PERFORMANCE CHARACTERISTICS (Continued)

●XC6403/04 Series (Continued)

(15) Load Transient Response (Continued)

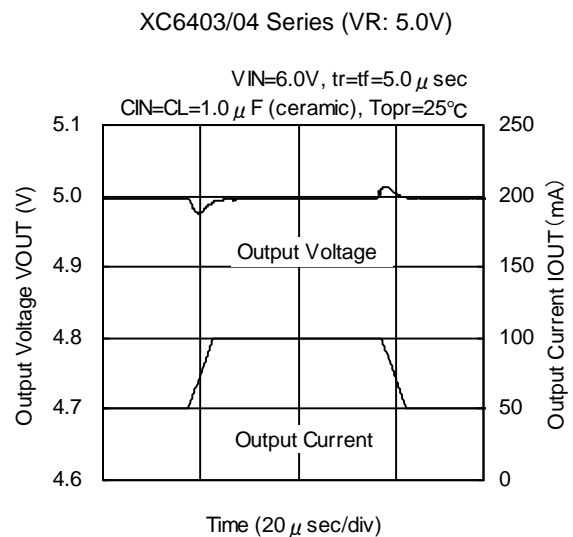
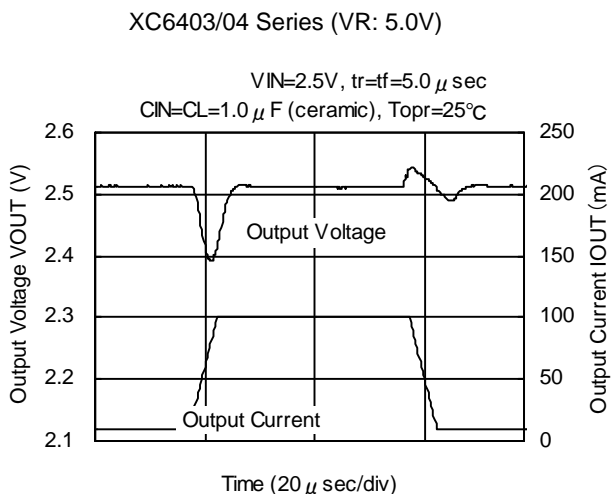
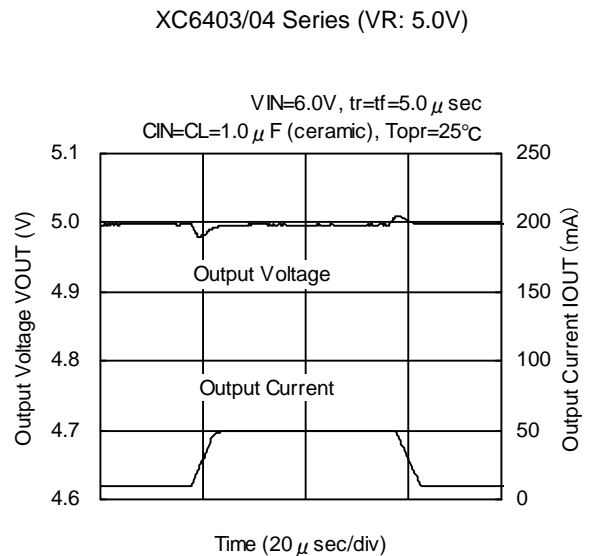
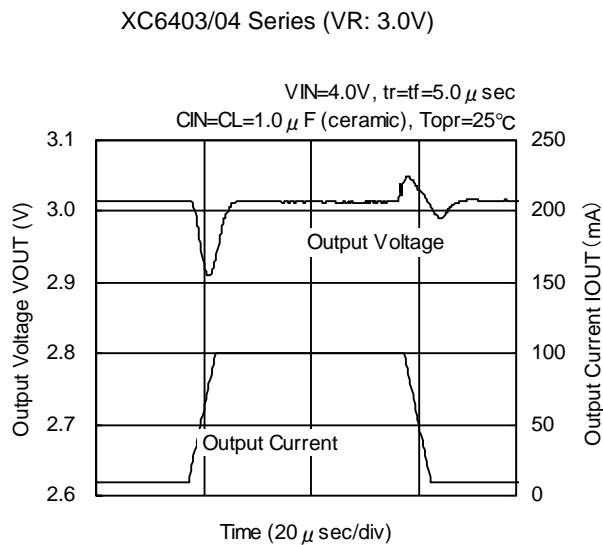
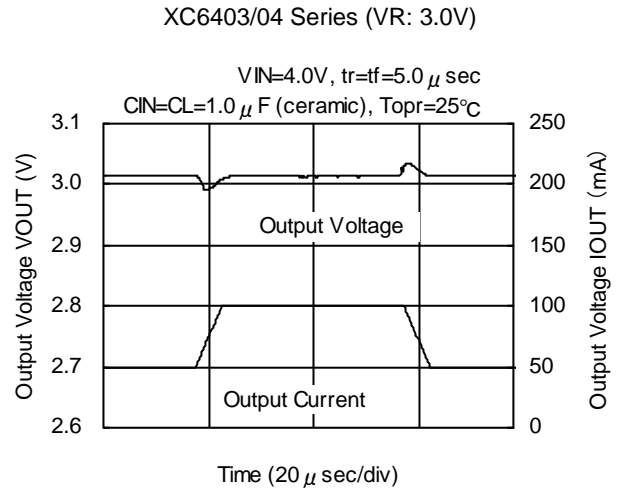
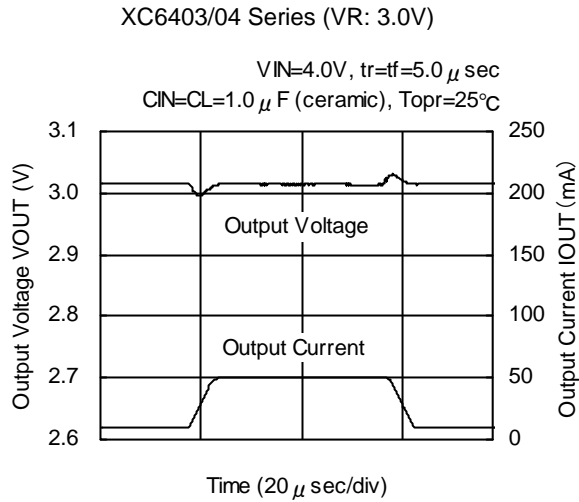

TYPICAL PERFORMANCE CHARACTERISTICS (Continued)

●XC6403/04 Series (Continued)

(15) Load Transient Response (Continued)

XC6403/04 Series (VR: 0.9V)

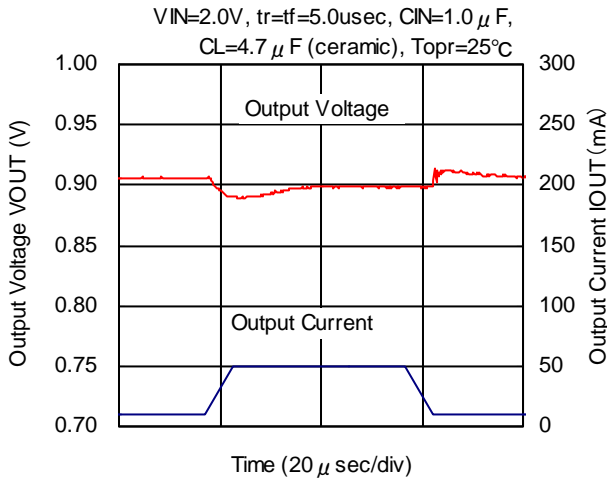

XC6403/04 Series (VR: 0.9V)

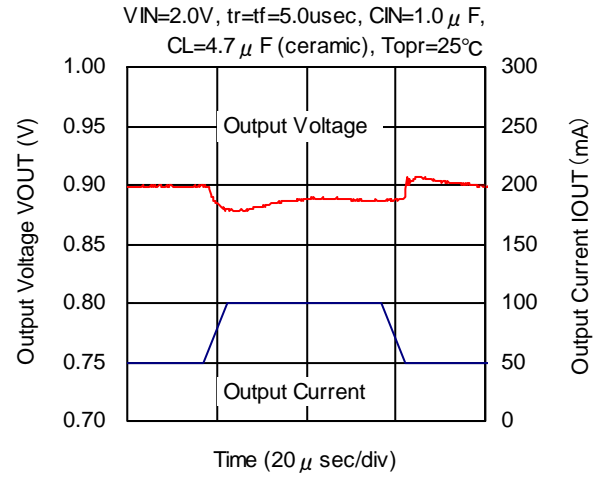

XC6403/04 Series (VR: 0.9V)

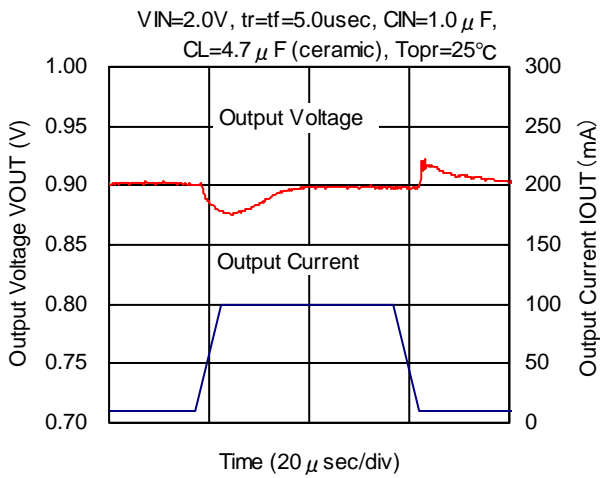

TYPICAL PERFORMANCE CHARACTERISTICS (Continued)

(16) Ripple Rejection Rate

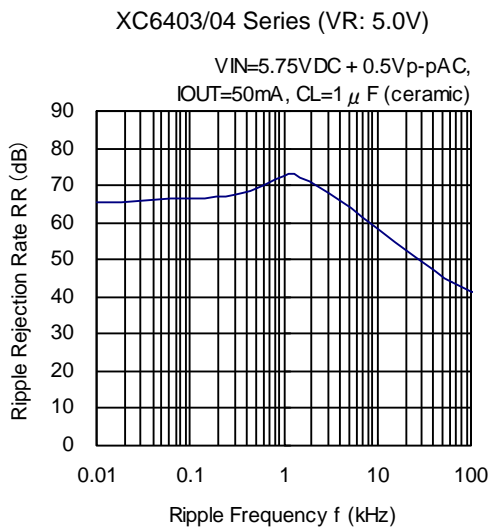
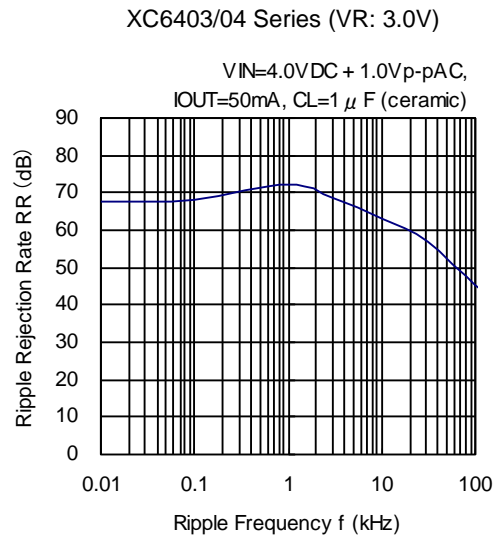
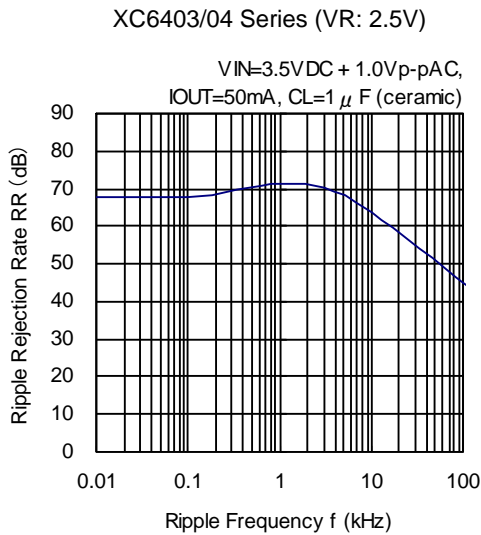
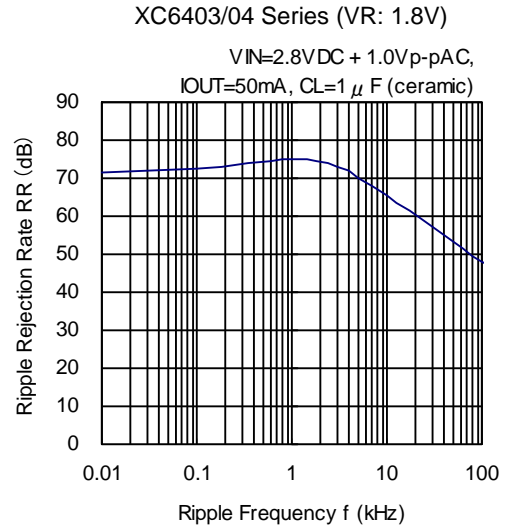
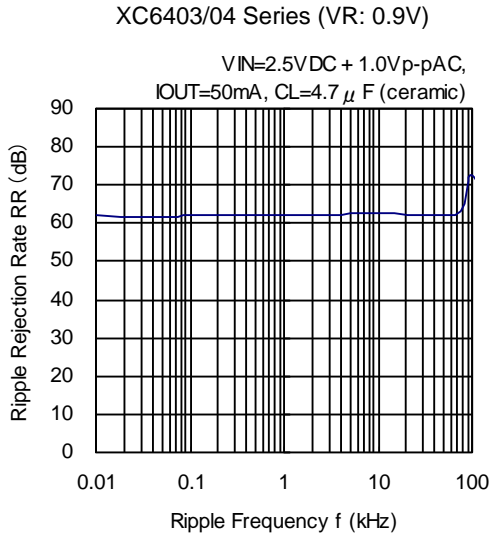

PACKAGING INFORMATION

● SOT-25

Unit : mm

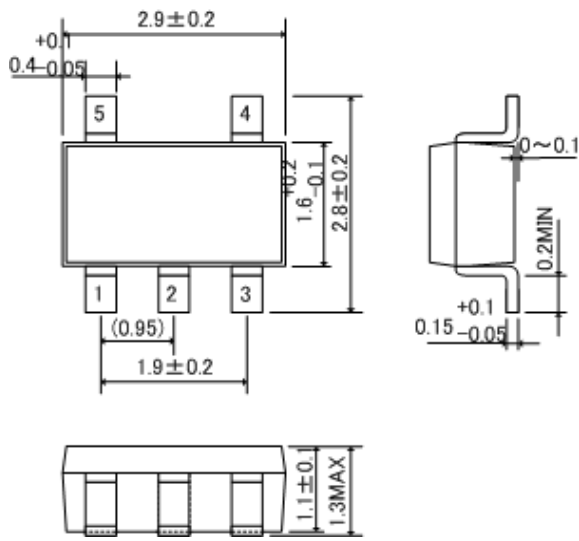

● SOT89-5

Unit : mm

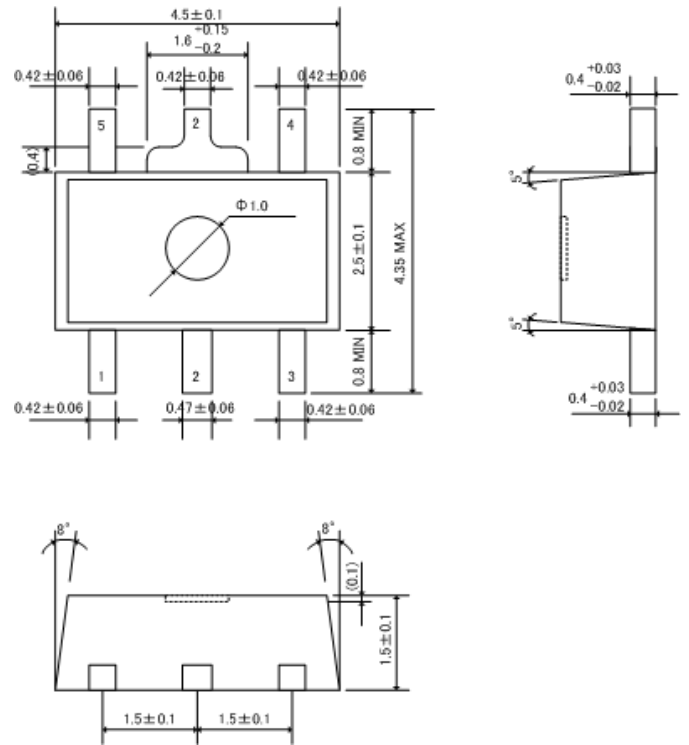

● USP-6B

Unit : mm

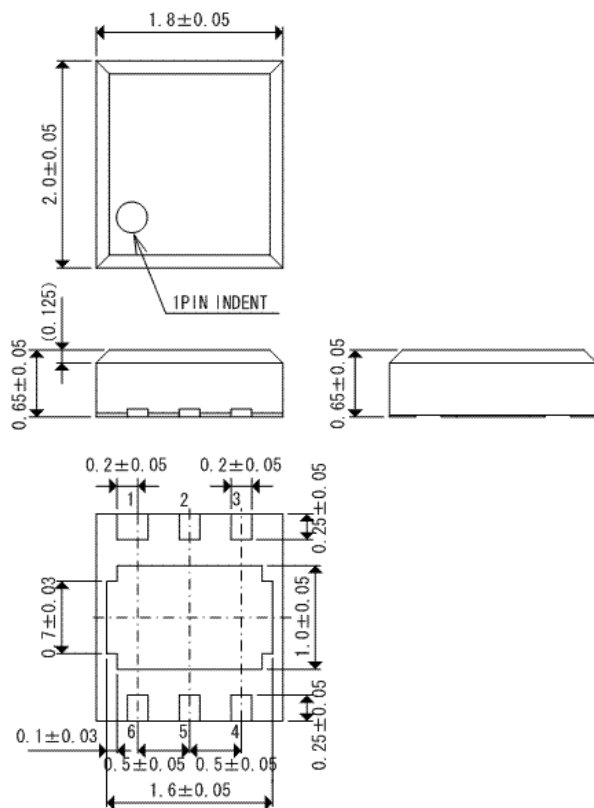

● USP-6B Reference Pattern Layout

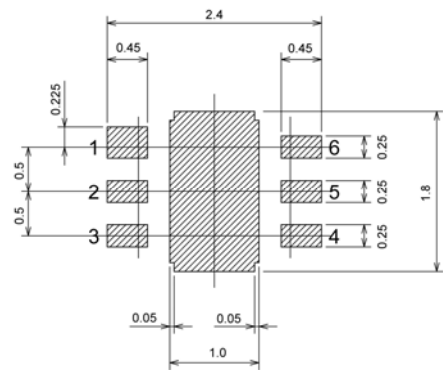

● USP-6B Reference Metal Mask Design

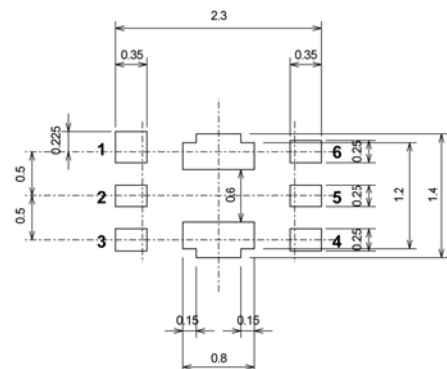

MARKING RULE

● SOT-25 / SOT-89-5

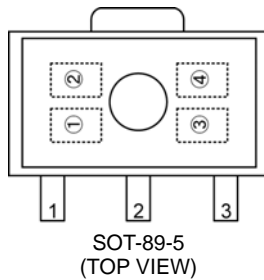
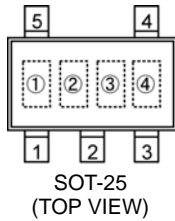

① represents product series

MARK	PRODUCT SERIES
<u>3</u>	XC6403xxxxxx
<u>4</u>	XC6404xxxxxx

②③ represents internal sequential number
Sequential numbering rule

1) Order

MARK	NUMBERING RULE
1	01~09
2	10~99
3	A0~A9
4	B0~B9
5	~Z9

*G, I, J, O, Q, W excluded

2) The same marking is printed on the product with same optional functions, product type, detect voltage, and output voltage although packages are different.

④ represents production lot number
0 to 9, A to Z reverse character 0 to 9, A to Z repeated (G, I, J, O, Q, W excluded)

● USP-6B

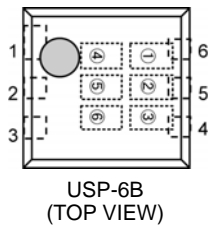

① represents product series

MARK	PRODUCT SERIES
2	XC6403xxxxDx
3	XC6404xxxxDx

② represents optional functions

MARK	OPTIONAL FUNCTIONS	PRODUCT SERIES
A	Toggle and EN Function	XC6403/04AxxDx
B	Toggle, EN Function, VD signal/VR OFF Function	XC6403/04BxxDx
C	EN Function	XC6403/04CxxDx
D	CE Function	XC6403/04DxxDx
E	VSEN Pin	XC6403/04ExxDx
F	Cd Pin	XC6403/04FxxDx

MARKING RULE (Continued)

● USP-6B (Continued)

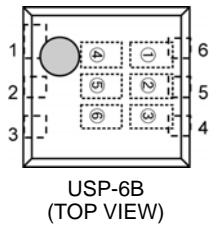

③ represents product type

MARK	CE/EN FUNCTION	EN / CE LOGIC	PULL-UP/DOWN RESISTANCE	VD SENSE PIN	VD OUTPUT LOGIC	PRODUCT SERIES
A	Function	High Active	Pull-Down Function	V _{IN}	Detect L	XC6403/04xAxxDx
B	Function	High Active	Pull-Down Function	V _{IN}	Detect H	XC6403/04xBxxDx
C	Function	High Active	Pull-Down Function	V _{ROUT}	Detect L	XC6403/04xCxxDx
D	Function	High Active	Pull-Down Function	V _{ROUT}	Detect H	XC6403/04xDxxDx
E	Function	High Active	Nonfunctional	V _{IN}	Detect L	XC6403/04xExxDx
F	Function	High Active	Nonfunctional	V _{IN}	Detect H	XC6403/04xFxxDx
H	Function	High Active	Nonfunctional	V _{ROUT}	Detect L	XC6403/04xHxxDx
K	Function	High Active	Nonfunctional	V _{ROUT}	Detect H	XC6403/04xKxxDx
L	Function	Low Active	Pull-Up Function	V _{IN}	Detect L	XC6403/04xLxxDx
M	Function	Low Active	Pull-Up Function	V _{IN}	Detect H	XC6403/04xMxxDx
N	Function	Low Active	Pull-Up Function	V _{ROUT}	Detect L	XC6403/04xNxxDx
P	Function	Low Active	Pull-Up Function	V _{ROUT}	Detect H	XC6403/04xPxxDx
R	Function	Low Active	Nonfunctional	V _{IN}	Detect L	XC6403/04xRxxDx
S	Function	Low Active	Nonfunctional	V _{IN}	Detect H	XC6403/04xSxxDx
T	Function	Low Active	Nonfunctional	V _{ROUT}	Detect L	XC6403/04xTxxDx
U	Function	Low Active	Nonfunctional	V _{ROUT}	Detect H	XC6403/04xUxxDx
V	Nonfunctional	-	-	V _{IN} / V _{SEN}	Detect L	XC6403/04xVxxDx
X	Nonfunctional	-	-	V _{ROUT} /V _{SEN}	Detect H	XC6403/04xXxxDx
Y	Nonfunctional	-	-	V _{ROUT} /V _{SEN}	Detect L	XC6403/04xYxxDx
Z	Nonfunctional	-	-	V _{ROUT} /V _{SEN}	Detect H	XC6403/04xZxxDx

④,⑤ represents output voltage and detect voltage
ex.)

MARK		OUTPUT VOLTAGE		PRODUCT SERIES
④	⑤	V _{ROUT} (V)	V _{DOUT} (V)	
3	0	4.0	4.3	XC6403/04**30D*

⑥ represents production lot number
0 to 9,A to Z repeated (G, I, J, O, Q, W excluded)
Note: No character inversion used.

1. The products and product specifications contained herein are subject to change without notice to improve performance characteristics. Consult us, or our representatives before use, to confirm that the information in this datasheet is up to date.
2. We assume no responsibility for any infringement of patents, patent rights, or other rights arising from the use of any information and circuitry in this datasheet.
3. Please ensure suitable shipping controls (including fail-safe designs and aging protection) are in force for equipment employing products listed in this datasheet.
4. The products in this datasheet are not developed, designed, or approved for use with such equipment whose failure or malfunction can be reasonably expected to directly endanger the life of, or cause significant injury to, the user.
(e.g. Atomic energy; aerospace; transport; combustion and associated safety equipment thereof.)
5. Please use the products listed in this datasheet within the specified ranges.
Should you wish to use the products under conditions exceeding the specifications, please consult us or our representatives.
6. We assume no responsibility for damage or loss due to abnormal use.
7. All rights reserved. No part of this datasheet may be copied or reproduced without the prior permission of TOREX SEMICONDUCTOR LTD.

TOREX SEMICONDUCTOR LTD.