

High Current, High Speed LDO Regulators, Voltage Detector Function

■ GENERAL DESCRIPTION

The XC6413/XC6414 series are highly precise, low noise, positive voltage LDO regulators with voltage detector manufactured using CMOS processes which features high ripple rejection and low dropout. The series is composed of a voltage reference, an error amplifier, a current limiter and a phase compensation circuit plus a driver transistor. Detect voltage is selectable in 0.1V increments within a range of 0.9V ~ 6.0V and VR output voltage is selectable within a range of 0.9V ~ 5.5V. The series is also compatible with low ESR ceramic capacitors which give added output stability. This stability can be maintained even during load fluctuations due to the excellent transient response of the series. The current limiter's foldback circuit operates as a short-circuit protection as well as the output current limiter for the output pin. The series provides optional user selection for a variety of circuit applications such as detector monitoring, detector output logic, CE and EN pin input logic, internal pull-up/down resistors. The IC's internal regulator circuit can be placed in stand-by mode via the EN function with the XC6413/14A to C series. The whole IC can be placed in stand-by mode via the CE function with the XC6413/14D series (semi-custom). In the stand-by mode, power consumption is greatly reduced. The XC6413/14A and B series features a toggle operation function. The regulator output can be OFF when the XC6413/14B series detects voltage (semi-custom). The XC6413/14E series can monitor another power source by using the VSEN pin (semi-custom). The XC6413/14F series can delay the detector output. Delay time can be controlled by the use of an external capacitor (semi-custom).

■ APPLICATIONS

- Mobile phones, Cordless phones
- Wireless communication equipment
- Cameras, Video recorders
- Portable games
- Portable AV equipment
- Reference voltage
- Battery powered equipment

■ FEATURES

Maximum Output Current	: 300mA (380mA limit) ($1.8 \leq V_{ROUT} \leq 5.5V$) [XC6413] 500mA (600mA limit) ($2.5V \leq V_{ROUT} \leq 5.5V$) [XC6414]
Dropout Voltage	: 200mV @ $I_{ROUT}=100mA$
Operating Voltage Range	: 2.0V ~ 10.0V
VR Output Voltage Range	: 0.9V ~ 5.5V (0.1V increments)
Detect Voltage Range	: 0.9V ~ 6.0V (0.1V increments, $\pm 2\%$) More than 2.0V (V_{IN} sensing)
VR Output Voltage Accuracy	: $\pm 2\%$
Detect Voltage Accuracy	: $\pm 2\%$
VR.VD Temperature Coefficient	: $\pm 100ppm/^{\circ}C$ (TYP.)
Low Power Consumption	: $35 \mu A$ (TYP.)
High Ripple Rejection	: 65dB @ 10kHz
Low ESR Capacitor	: Ceramic Capacitor Compatible
Operating Ambient Temperature	: $-40^{\circ}C \sim +85^{\circ}C$
Packages	: SOT-25, SOT-89-5, USP-6B
Environmentally Friendly	: EU RoHS Compliant, Pb Free

■ TYPICAL APPLICATION CIRCUITS

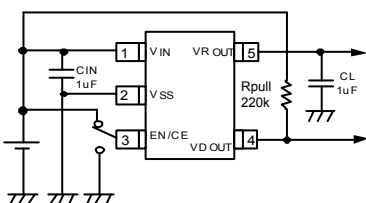

XC6413A ~ D Series

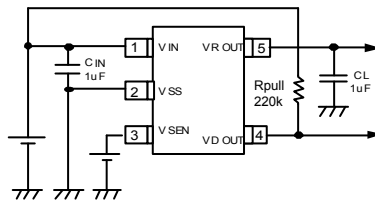

XC6413E Series

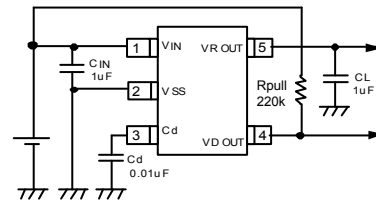

XC6413F Series

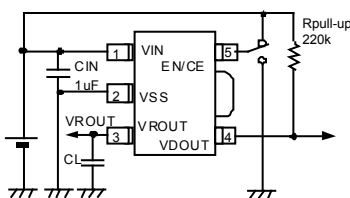

XC6414A ~ D Series

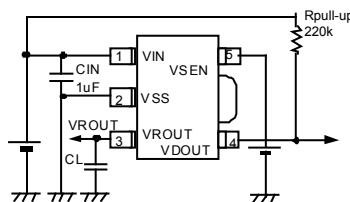

XC6414E Series

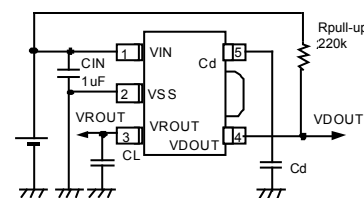

XC6414F Series

PIN CONFIGURATION

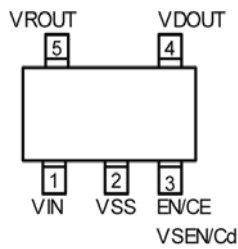

SOT-25 (TOP VIEW)

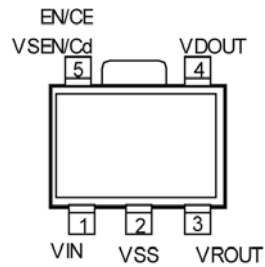

SOT-89-5 (TOP VIEW)

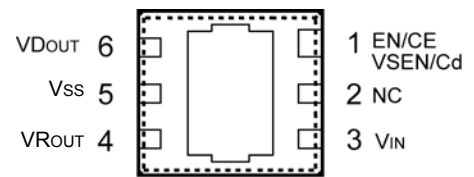

USP-6B (BOTTOM VIEW)

*The dissipation pad for the USP-6B package should be solder-plated in recommended mount pattern and metal masking so as to enhance mounting strength and heat release. If the pad needs to be connected to other pins, it should be connected to the Vss (No. 5) pin.

PIN ASSIGNMENT

PIN NUMBER			PIN NAME	FUNCTION
SOT-25	SOT-89-5	USP-6B		
1	1	3	V _{IN}	Power Input
2	2	5	V _{SS}	Ground
3	5	1	EN	VR ON / OFF Control
3	5	1	CE	ON / OFF Control
3	5	1	V _{SEN}	VD Monitoring
3	5	1	Cd	Delay Capacitor Connection
4	4	6	V _{DOUT}	VD Output
5	5	4	V _R OUT	VR Output
—	—	2	NC	No connection

■ PRODUCT CLASSIFICATION

● SELECTION GUIDE

1. TOGGLE FUNCTION, VD SELF-SATURATION AS OPTION

SERIES	TOGGLE FUNCTION (BUILT-IN)
XC6413/14A	VD with Toggle Function
XC6413/14B	VD with Toggle Function and Self-Saturation
XC6413/14C ~ F	VD with No Toggle Function

2. STAND-BY MODE FUNCTION AS OPTION

SERIES	STAND-BY MODE FUNCTION
XC6413/14A ~ C	VR with Stand-By Mode Function
XC6413/14D	Chip Stand-By Mode Function
XC6413/14E, F	No Stand-By Mode Function

3. CE / EN INPUT LOGIC, INTERNAL PULL-UP/DOWN AS OPTION (*A ~ D Series)

SERIES	CE INPUT LOGIC
XC6413/14 * A ~ D	High Active with Pull Down
XC6413/14 * E ~ K	High Active with No Pull Down
XC6413/14 * L ~ P	Low Active with Pull Up
XC6413/14 * R ~ U	Low Active with No Pull Up

4. VD SENSE AS OPTION (*A ~ D and F Series)

SERIES	VD SENSE PIN
XC6413/14 * A, B, E, F, L, M, R, S, V, X	V _{IN}
XC6413/14 * C, D, H, K, N, P, T, U, Y, Z	V _{OUT}
XC6413/14 E V ~ Z	V _{SEN}

5. VD OUTPUT LOGIC AS OPTION

SERIES	VD OUTPUT LOGIC FUNCTION
XC6413/14A ~ F	Detect L or Detect H

6. VD DELAY FUNCTION AS OPTION

SERIES	DELAY FUNCTION
XC6413/14A ~ E	No Delay
XC6413/14F	Delay Time Adjustable by Connecting Cd

● Ordering Information

XC6413/XC6414①②③④⑤⑥-⑦^(*)

DESIGNATOR	ITEM	SYMBOL	DESCRIPTION
①	Operational Function	A	Toggle and EN function (Semi-custom products)
		B	Toggle, EN function, VD signal/VR OFF function (Semi-custom products)
		C	EN function (Semi-custom products)
		D	CE function (Semi-custom products)
		E	V _{SEN} Pin (Semi-custom products)
		F	Cd pin
②	Type of Regulator	-	As in the chart below.
③④	Output Voltage & Detect Voltage	-	Internally set sequential number relating to output voltage and detect voltage (refer to the chart below) VR setting output voltage range: 0.9V ~ 5.5V Detect voltage setting range: 0.9V ~ 6.0V 100mV increments are available
⑤⑥-⑦	Packages (Order Unit)	MR	SOT-25 (3,000/Reel)
		MR-G	SOT-25 (3,000/Reel)
		PR	SOT-89-5 (1,000/Reel)
		PR-G	SOT-89-5 (1,000/Reel)
		DR	USP-6B (3,000/Reel)
		DR-G	USP-6B (3,000/Reel)

^(*) The "-G" suffix indicates that the products are Halogen and Antimony free as well as being fully RoHS compliant.

■ PRODUCT CLASSIFICATION (Continued)

● Ordering Information

PIN NUMBER : ② Types

②	EN / CE FUNCTION	EN / CE LOGIC	PULL UP/DOWN RESISTANCE	VD SENSE PIN	VD OUTPUT LOGIC	PIN NUMBER①
A	Function	High Active	Pull-down Function	VIN	Detect L	A ~ D Series
B	Function	High Active	Pull-down Function	VIN	Detect H	
C	Function	High Active	Pull-down Function	VROUT	Detect L	
D	Function	High Active	Pull-down Function	VROUT	Detect H	
E	Function	High Active	Nonfunctional	VIN	Detect L	
F	Function	High Active	Nonfunctional	VIN	Detect H	
H	Function	High Active	Nonfunctional	VROUT	Detect L	
K	Function	High Active	Nonfunctional	VROUT	Detect H	
L	Function	Low Active	Pull-up Function	VIN	Detect L	
M	Function	Low Active	Pull-up Function	VIN	Detect H	
N	Function	Low Active	Pull-up Function	VROUT	Detect L	
P	Function	Low Active	Pull-up Function	VROUT	Detect H	
R	Function	Low Active	Nonfunctional	VIN	Detect L	
S	Function	Low Active	Nonfunctional	VIN	Detect H	
T	Function	Low Active	Nonfunctional	VROUT	Detect L	
U	Function	Low Active	Nonfunctional	VROUT	Detect H	
V	Nonfunctional	-	-	VIN / VSEN	Detect L	E & F Series
X	Nonfunctional	-	-	VIN / VSEN	Detect H	
Y	Nonfunctional	-	-	VROUT	Detect L	F Series
Z	Nonfunctional	-	-	VROUT	Detect H	

*The XC6413/14A ~ E series are semi-custom products. For further detail, please ask your sales contacts.

PIN NUMBER: ③, ④ Types (80 ~ 99 : Standard voltage products)

③④	VROUT	VDOUT	③④	VROUT	VDOUT	③④	VROUT	VDOUT	③④	VROUT	VDOUT
01	-	-	11	-	-	80	1.8	1.6	90	1.3	2.0
02	-	-	12	-	-	81	2.8	3.1	91	1.5	2.0
03	-	-	13	-	-	82	1.8	2.0	92	-	-
04	-	-	14	-	-	83	2.5	2.8	93	-	-
05	-	-	15	-	-	84	2.85	3.2	94	-	-
06	-	-	16	-	-	85	3.0	3.3	95	-	-
07	-	-	17	-	-	86	3.5	3.8	96	-	-
08	-	-	18	-	-	87	3.0	4.2	97	-	-
09	-	-	19	-	-	88	3.3	4.0	98	-	-
10	-	-	20	-	-	89	-	-	99	-	-

Minimum order quantity of products other than standard products' is 15,000 pcs.

■ ABSOLUTE MAXIMUM RATINGS

PARAMETER		SYMBOL	RATINGS	UNIT
Input Voltage		V _{IN}	12.0	V
VR Output Current		V _{RIOUT}	700	mA
VR Output Voltage		V _{ROUT}	V _{SS} -0.3 ~ V _{IN} +0.3	V
VD Output Current		V _{DIOUT}	50	mA
VD Output Voltage		V _{DOUT}	V _{SS} -0.3 ~ 12.0	V
V _{CE} / V _{SEN} / Cd Voltage		V _{CE} / V _{SEN} / Cd	V _{SS} -0.3 ~ V _{IN} +0.3	V
Power Dissipation	SOT-25	P _d	250	mW
	SOT-89-5		500	
	USP-6B		100	
Operating Ambient Temperature		T _{opr}	- 40 ~ +85	°C
Storage Temperature		T _{stg}	- 55 ~ +125	°C

XC6413/XC6414 Series

ELECTRICAL CHARACTERISTICS

XC6413/14 FV / FX / FY / FZ Series

Ta=25°C

	PARAMETER	SYMBOL	CONDITIONS ^(†1)	MIN.	TYP.	MAX.	UNIT	CIRCUIT	
Regulator Block	Output Voltage ^{(†2)(†3)}	$V_{ROUT(E)}$	$I_{ROUT}=30mA$	$\times 0.98$	$V_{ROUT(T)}$	$\times 1.02$	V	1	
	Maximum Output Current (XC6413 Series)	$I_{ROUTMAX}$	$V_{IN}=V_{ROUT(T)}+1.0V$ When $V_{ROUT} \leq 2.1V, V_{IN}=3.1V$	300	-	-	mA	1	
	Maximum Output Current (XC6414, 0.9 ~ 2.4V)	$I_{ROUTMAX}$	$V_{IN} = V_{ROUT(T)} + 2.0V$	400	-	-	mA	1	
	Maximum Output Current (XC6414, 2.5 ~ 4.9V)	$I_{ROUTMAX}$	$V_{IN} = V_{ROUT(T)} + 2.0V$	500	-	-	mA	1	
	Load Regulation	ΔV_{ROUT}	$1mA \leq I_{ROUT} \leq 100mA$	-	15	50	mV	1	
	Dropout Voltage ^(†4)	V_{dif1}	$I_{ROUT}=30mA$	E-1			mV	1	
		V_{dif2}	$I_{ROUT}=100mA$	E-2			mV	1	
	Supply Current (FV / FX / FY / FZ Series)	I_{DD}	$V_{IN}=V_{ROUT(T)}+1.0V$	-	35	70	μA	2	
	Line Regulation	$\frac{\Delta V_{ROUT}}{\Delta V_{IN} \cdot V_{OUT}}$	$V_{ROUT(T)}+1.0V \leq V_{IN} \leq 10.0V$ $I_{ROUT}=30mA$ $V_{ROUT(T)} \leq 1.75V, I_{ROUT}=10mA$	-	0.01	0.20	% / V	1	
	Input Voltage	V_{IN}		2.0	-	10.0	V	-	
	Output Temperature Characteristics	$\frac{\Delta V_{ROUT}}{\Delta T_{opr} \cdot V_{ROUT}}$	$I_{ROUT}=30mA$ $-40^{\circ}C \leq T_{opr} \leq 85^{\circ}C$	-	± 100	-	ppm / °C	1	
	Ripple Rejection Rate	PSRR	$V_{IN}=[V_{ROUT(T)}+1.0]V+0.5Vp-pAC$ When $V_{ROUT(T)} \leq 1.25V$ $\rightarrow V_{IN}=2.25V+0.5Vp-pAC$ $I_{ROUT}=50mA, f=10kHz$	-	65	-	dB	3	
	Current Limit (XC6413, V_{ROUT} 1.8V or more)	I_{RLIM}	$V_{IN}=V_{ROUT(T)}+1.0V$ When $V_{ROUT} \leq 2.1V, V_{IN}=3.1V$	300	380	-	mA	1	
	Current Limit (XC6413, V_{ROUT} 1.7V or less)	I_{RLIM}	$V_{IN}=3.1V$	-	380	-	mA	1	
	Current Limit (XC6414, V_{ROUT} 2.4V or less)	I_{RLIM}	$V_{IN}=V_{ROUT(T)}+2.0V$	-	600	-	mA	1	
	Current Limit (XC6414, V_{ROUT} 2.5V or more)	I_{RLIM}	$V_{IN}=V_{ROUT(T)}+2.0V$	500	600	-	mA	1	
Short Circuit Current (XC6413 Series)	I_{RSHORT}	$V_{IN}=V_{ROUT(T)}+1.0V$ When $V_{ROUT(T)} \leq 2.1V, V_{IN}=3.1V$	-	30	-	mA	1		
Short Circuit Current (XC6414 Series)	I_{RSHORT}	$V_{IN}=V_{ROUT(T)}+2.0V$ When $V_{ROUT(T)} \leq 1.5V, V_{IN}=3.1V$	-	30	-	mA	1		
Detector Block	Detect Voltage ^{(†5)(†6)}	$V_{DF(E)}$		$\times 0.98$	$V_{DF(T)}$	$\times 1.02$	V	4	
	Hysteresis Range	V_{HYS}		$V_{DF(T)}$ $\times 0.02$	$V_{DF(T)}$ $\times 0.05$	$V_{DF(T)}$ $\times 0.08$	V	4	
	Output Current ^(†7)	I_{DOUT}	$V_{DOUT} = 0.5V$	$V_{IN} = 2.0V$	2.0	5.0	-	mA	5
				$V_{IN} = 3.0V$	4.0	7.5	-		
				$V_{IN} = 4.0V$	5.0	9.5	-		
				$V_{IN} = 5.0V$	6.0	10.5	-		
				$V_{IN} = 6.0V$	6.5	11.5	-		
				$V_{IN} = 7.0V$	7.0	12.5	-		
$V_{IN} = 8.0V$				7.5	13.5	-			
Detect Voltage Temperature Characteristics	$\frac{\Delta V_{DF}}{\Delta T_{opr} \cdot V_{DF}}$	$-40^{\circ}C \leq T_{opr} \leq 85^{\circ}C$	-	± 100	-	ppm / °C	4		
Delay Resistance	R_{DELAY}	$V_{IN}=7.0V, C_d=0V$ Delay Resistance=7.0V/Delay Current	1.0	2.0	2.5	M Ω	6		

NOTE

- *1 Unless otherwise stated, $V_{IN}=V_{OUT(T)}+1.0V$
- *2 $V_{ROUT(T)}$: Nominal VR output voltage
- *3 $V_{OUT(E)}$: Effective VR output voltage
(i.e. the VR output voltage when " $V_{ROUT(T)}+1.0V$ " is provided at the V_{IN} pin while maintaining a certain I_{ROUT} value).
- *4 $V_{dif}=V_{IN1}-V_{ROUT1}$
 V_{ROUT} : A voltage equal to 98% of the VR output voltage whenever a stabilized ($V_{ROUT(T)}+1.0V$) is input with each I_{ROUT} .
 V_{IN1} : The input voltage when V_{OUT1} , which appears as Input voltage is gradually decreased.
- *5 $V_{DF(T)}$: Nominal detect voltage value
- *6 $V_{DF(E)}$: Effective detect voltage value.
- *7 VD supply current : sink current during detection.

ELECTRICAL CHARACTERISTICS

VR Dropout Voltage

SYMBOL PARAMETER NOMINAL DETECT VOLTAGE OUTPUT VOLTAGE	E-0		E-1		E-2	
	OUTPUT VOLTAGE DETECT VOLTAGE		DROPOUT VOLTAGE 1 (mV) (I _{OUT} =30mA)		DROPOUT VOLTAGE 2 (mV) (I _{OUT} =100mA)	
	(V)		Ta=25°C		Ta=25°C	
	V _{ROUT(T)} V _{DF(T)}	V _{ROUT} / V _{DF}		V _{dif1}	V _{dif1}	V _{dif2}
	MIN.	MAX.	TYP.	MAX.	TYP.	MAX.
0.90	0.870	0.930	1050	1100	1150	1200
1.00	0.970	1.030	1000	1100	1050	1200
1.10	1.070	1.130	900	1000	950	1100
1.20	1.170	1.230	800	900	850	1000
1.30	1.270	1.330	700	800	750	900
1.40	1.370	1.430	600	700	650	800
1.50	1.470	1.530	500	600	550	700
1.60	1.568	1.632	400	500	500	600
1.70	1.666	1.734	300	400	400	500
1.80	1.764	1.836	200	300	300	400
1.90	1.862	1.938	120	150	280	380
2.00	1.960	2.040	80	120	240	350
2.10	2.058	2.142	80	120	240	330
2.20	2.156	2.244	80	120	240	330
2.30	2.254	2.346	80	120	240	310
2.40	2.352	2.448	80	120	240	310
2.50	2.450	2.550	70	100	220	290
2.60	2.548	2.652	70	100	220	290
2.70	2.646	2.754	70	100	220	290
2.80	2.744	2.856	70	100	220	270
2.90	2.842	2.958	70	100	220	270
3.00	2.940	3.060	60	90	200	270
3.10	3.038	3.162	60	90	200	250
3.20	3.136	3.264	60	90	200	250
3.30	3.234	3.366	60	90	200	250
3.40	3.332	3.468	60	90	200	250
3.50	3.430	3.570	60	90	200	250
3.60	3.528	3.672	60	90	200	250
3.70	3.626	3.774	60	90	200	250
3.80	3.724	3.876	60	90	200	250
3.90	3.822	3.978	60	90	200	250
4.00	3.920	4.080	60	80	180	230
4.10	4.018	4.182	60	80	180	230
4.20	4.116	4.284	60	80	180	230
4.30	4.214	4.386	60	80	180	230
4.40	4.312	4.488	60	80	180	230
4.50	4.410	4.590	60	80	180	230
4.60	4.508	4.692	60	80	180	230
4.70	4.606	4.794	60	80	180	230
4.80	4.704	4.896	60	80	180	230
4.90	4.802	4.998	60	80	180	230
5.00	4.900	5.100	50	70	160	210
5.10	4.998	5.202	50	70	160	210
5.20	5.096	5.304	50	70	160	210
5.30	5.194	5.406	50	70	160	210
5.40	5.292	5.508	50	70	160	210
5.50	5.390	5.610	50	70	160	210
5.60	5.488	5.712				
5.70	5.586	5.814				
5.80	5.684	5.916				
5.90	5.782	6.018				
6.00	5.880	6.120				

TEST CIRCUITS

XC6413/14F Series

● Circuit 1

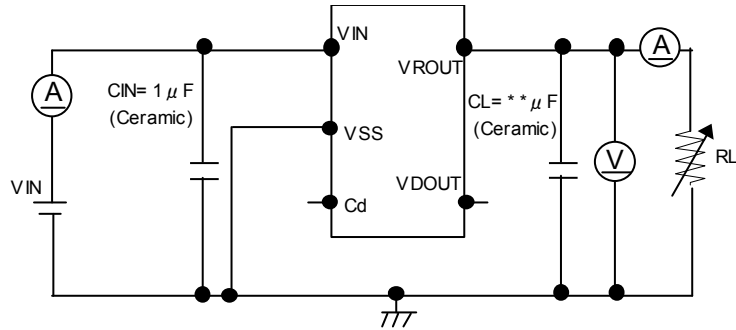

● Circuit 2

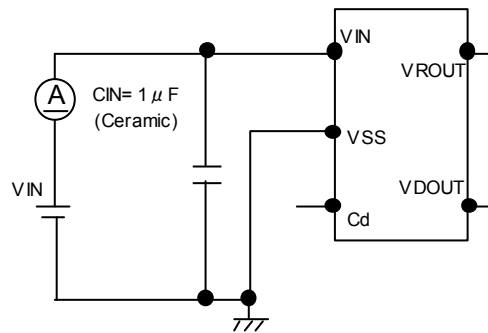

● Circuit 3

[XC6413F Series]
 $V_{ROUT} \leq 1.25V$
 $V_{IN} = \{2.25V\}VDC$
 $+0.5Vp-pAC$

[XC6414F Series]
 $V_{ROUT} \leq 0.9V$
 $V_{IN} = \{2.0V\}VDC$
 $+0.5Vp-pAC$

$V_{IN} = \{V_{ROUT} + 1.0V\}VDC$
 $+0.5Vp-pAC$

$V_{IN} = \{V_{ROUT} + 1.0V\}VDC$
 $+0.5Vp-pAC$

$V_{ROUT} > 4.75V$
 $V_{IN} = \{5.75V\}VDC$
 $+0.5Vp-pAC$

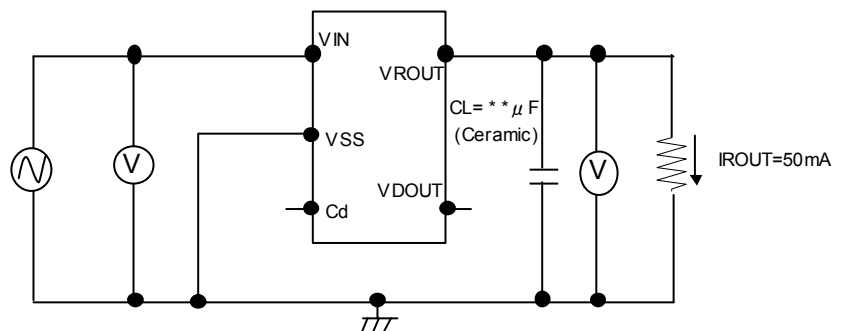

● Output Capacitor Corresponding Chart

V_{ROUT}	0.9 ~ 1.2V	1.3 ~ 1.7V	1.8 ~ 5.5V
CL	More than 4.7 μF	More than 2.2 μF	More than 1.0 μF

■ **TEST CIRCUITS (Continued)**

XC6413/14F Series

● **Circuit 4** [VD Sense, VIN Type]

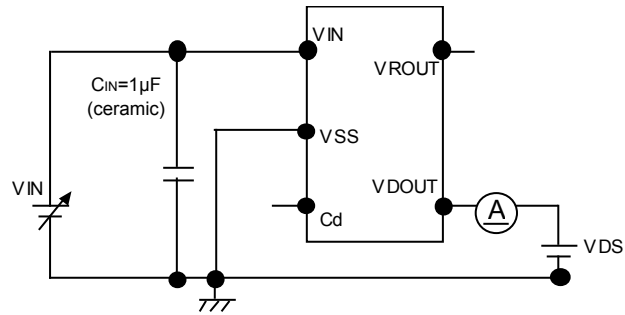

[VD Sense, VROUT Type]

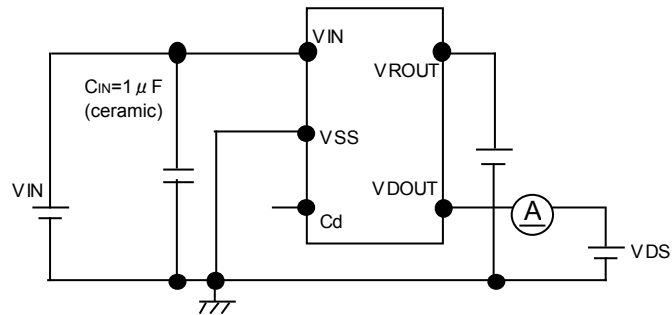

● **Circuit 5** [VD Sense, VIN Type]

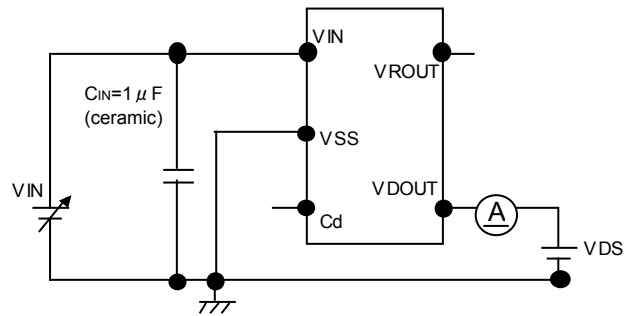

[VD Sense, VROUT Type]

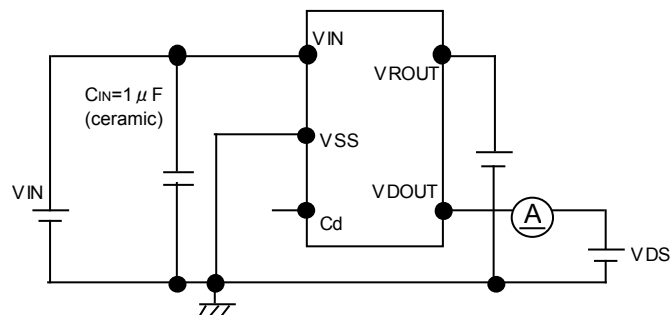

TEST CIRCUITS (Continued)

XC6413/14F Series

● Circuit 6 [VD Sense, VIN Type]

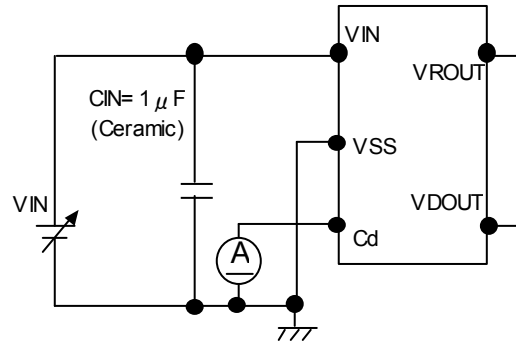

[VD Sense, VROUT Type]

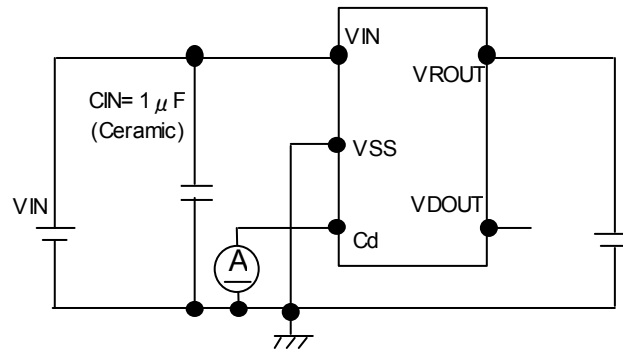

■ BLOCK DIAGRAMS

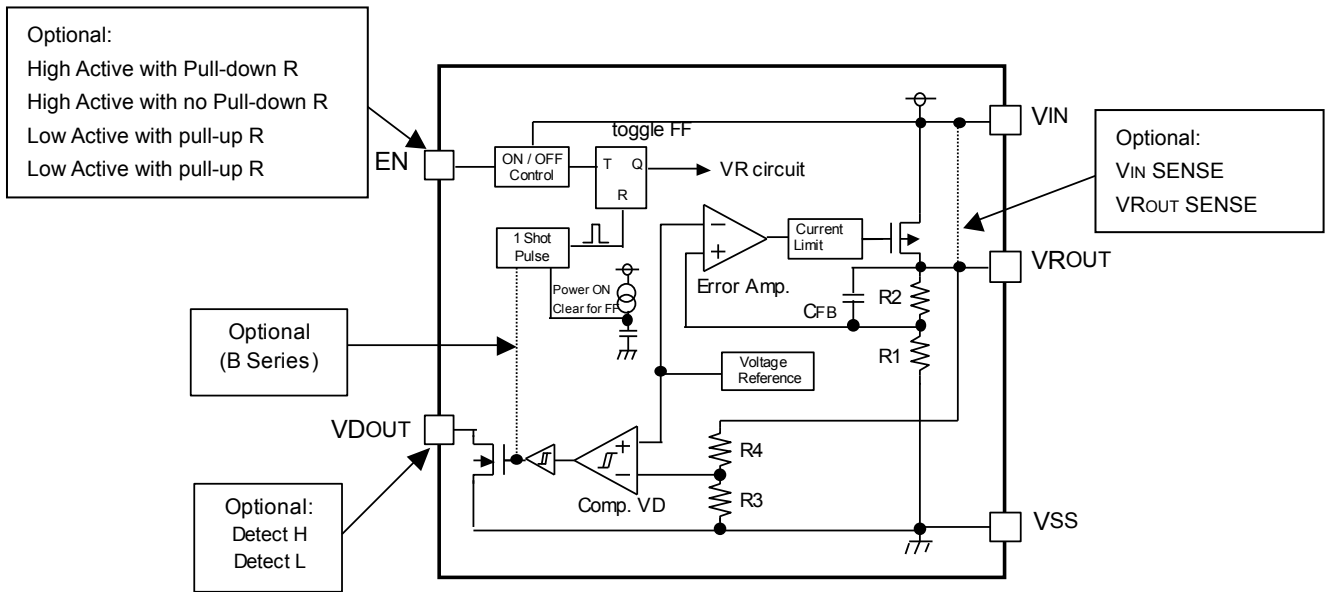

XC6413 / 14 A, B Series

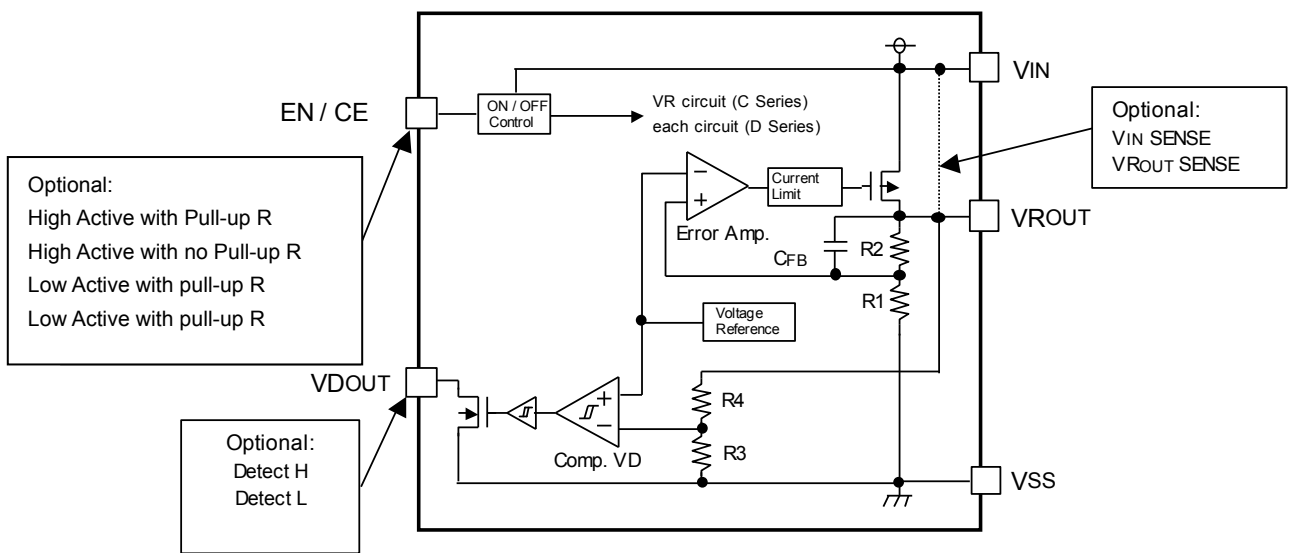

XC6413/14C, D Series

■ BLOCK DIAGRAMS (Continued)

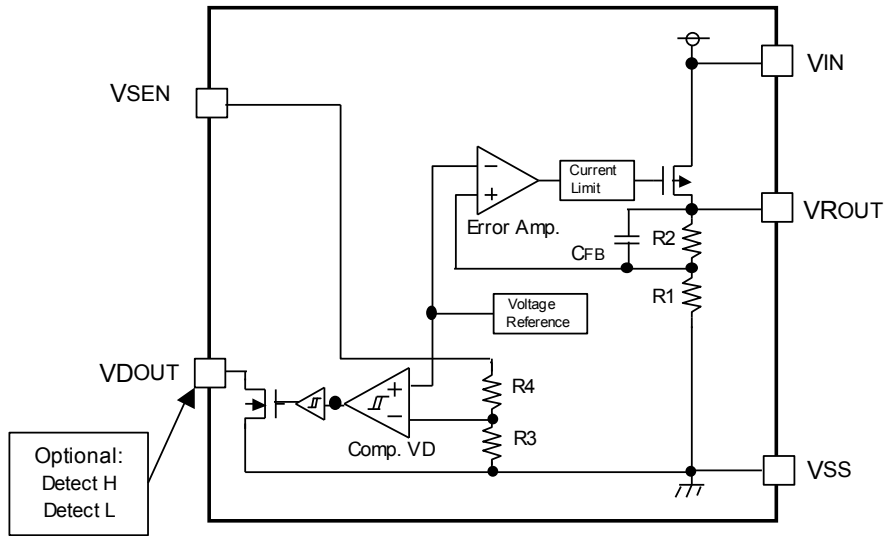

XC6413/14E Series

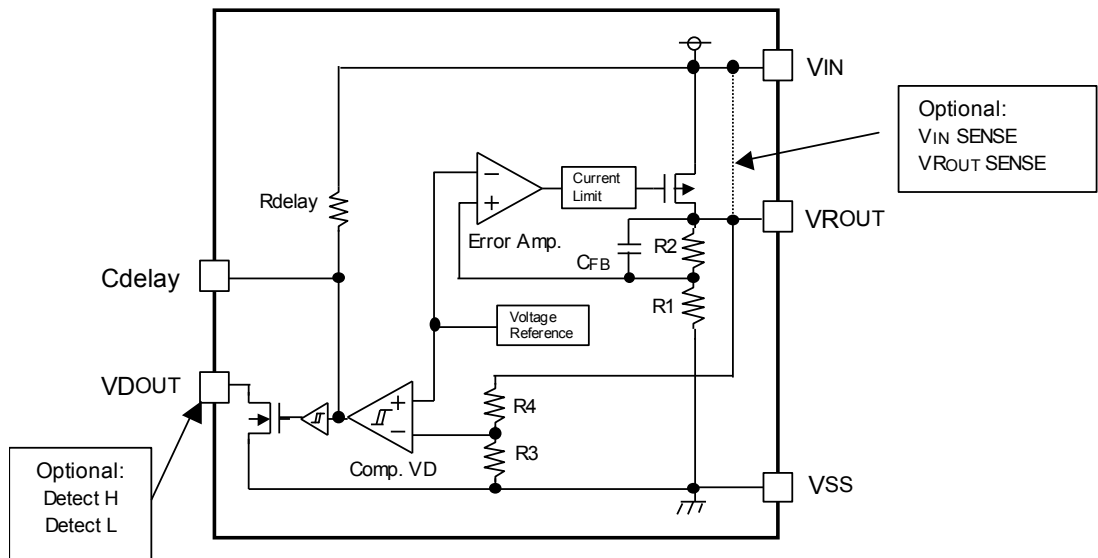

XC6413/14F Series

OPERATIONAL EXPLANATION

<Output Voltage Regulator Control>

The voltage, divided by resistors R1 & R2 which are connected to the V_{ROUT} pin is compared with the internal reference voltage by the error amplifier. The P-channel MOSFET, which is connected to the V_{ROUT} pin, is then driven by the subsequent output signal. The output voltage at the V_{ROUT} pin is controlled & stabilized by negative feedback. The current limit circuit and short circuit protection operate in relation to the level of output current. Further, the voltage regulator's internal circuitry can be shutdown via the EN or CE pin's signal.

<Detector Function with the XC6413/14 Series>

The series' detector function monitors the voltage divided by resistors R3 & R4 which are connected to the V_{ROUT} pin or the V_{IN} pin or the V_{SEN} pin, as well as monitoring the voltage of the internal reference voltage source via the comparator. The V_{DSEN} pin has options (please refer to the Selection Guide, item 4). A 'High' or 'Low' signal level can be output from the V_{DOUT} pin when the V_D pin voltage level goes below the detect voltage. The V_D output logic has options (please refer to the Selection Guide, item 5). As V_{DOUT} is an open-drain N-channel output, a pull-up resistor of about 220kΩ is needed to achieve a voltage output. Because of hysteresis at the detector function, output at the V_{DOUT} pin will invert when the detect voltage level increases above the release voltage (105% of the detect voltage). Even when the XC6413/14A, B, C, series are in stand-by mode, the voltage detector function operates and the output voltage at V_{DOUT} will output according to the voltage level at V_{DSENSE} voltage. For the XC6413/14A, B, C types, in stand-by, if a voltage of the recovery voltage is present at the V_{ROUT} pin (from another power source), the V_{DOUT} pin will be high impedance mode, and the pull up voltage will be output at V_{DOUT}. By connecting the C_{delay} pin to a capacitor (C_d), the XC6413/14F series can apply a delay time to V_{DOUT} voltage when releasing voltage. The delay time can be calculated from the internal resistance, R_{delay} (2MΩ, TYP., fixed) and the value of C_d as per the following equation.

$$Delay\ Time = C_{delay} \times R_{delay} \times 0.7$$

●Delay Time R_{delay}: 1.0 ~ 3.5MΩ, TYP:2.0MΩ

C _{delay}	DELAY TIME (TYP.)	DELAY TIME
0.01 μF	14msec	7 ~ 24.5msec
0.022 μF	30.8msec	15.4 ~ 53.9msec
0.047 μF	65.8msec	32.9 ~ 115.15msec
0.1 μF	140msec	70 ~ 245msec
0.22 μF	308msec	154 ~ 539msec
0.47 μF	658msec	329 ~ 1151.5msec
1 μF	1400msec	700 ~ 2450msec

<Low ESR Capacitors>

With the XC6403/04 series regulator, a stable output voltage is achievable even if low ESR capacitors are used, as a phase compensation circuit is built-in to the regulator. In order to ensure the effectiveness of the phase compensation, we suggest that an output capacitor (C_L) be connected as close as possible, between the output pin (V_{ROUT}) and the V_{SS} pin. Please use an output capacitor (C_L) with a capacitance, based on the chart below. We also suggest an input capacitor (C_{IN}) of 1 μF : this should be connected between V_{IN} and V_{SS} in order to stabilize input power source.

●Output Capacitor Corresponding Chart

V _{ROUT}	0.9 ~ 1.2V	1.3 ~ 1.7V	1.8 ~ 5.5V
C _L	More than 4.7 μF	More than 2.2 μF	More than 1.0 μF

<Current Limiter, Short-Circuit Protection>

The XC6413/14 series regulator offers a combination of current limit and circuit protection by means of a built-in fixed current limiter circuit and a foldback circuit. When the load current reaches the current limit level, the fixed current limiter circuit operates and output voltage drops. As a result of this drop in output voltage, the foldback circuit operates, the output voltage drops further and output current decreases. When the output pin is shorted, a current of about 50mA flows.

<EN / CE Pin>

The IC's internal regulator circuitry can be shut down via the signal from the EN pin with the XC6413/14A, B, C series. In shutdown mode, output at the V_{ROUT} pin will be pulled down to the V_{SS} level via R1 & R2. The whole IC's circuitry can be shut down via CE pin with the XC6413/14D series and power consumption can be reduced to around 0 μA (TYP.). While the voltage detector is in shutdown mode, the voltage detector output is in a post-detection state. When choosing Detect L, input current can be set by using the following formula.

$$Input\ Current = V_{IN}\ voltage / Pull-Up\ Resistance$$

OPERATIONAL EXPLANATION (Continued)

<EN / CE Pin (Continued)>

In stand-by mode, the above input current can be reduced by connecting a pull-up resistor between V_{ROUT} and V_{DOUT}.

Note that as the XC6413/14*E to K types of the XC6413/14A to D series are 'High Active / No Pull-Down' and XC6413/14*R to U types of the XC6413/14A to D series are 'Low Active / No Pull-Up', operations will become unstable with the CE pin open (See the chart below).

SERIES	EN/CE INPUT LOGIC	(*A~D Series)
XC6413/14 * A ~ D	High Active with Pull-Down	
XC6413/14 * E ~ K	High Active with No Pull-Down	
XC6413/14 * L ~ P	Low Active with Pull-Up	
XC6413/14 * R ~ U	Low Active with No Pull-Up	

We suggest that you use this IC with either a V_{IN} voltage or a V_{SS} voltage input at the EN or CE pin. If this IC is used with the correct specifications for the EN or CE pin, the IC will operate normally. However, supply current may increase as a result of through current in the IC's internal circuitry if a voltage other than V_{IN} or V_{SS} is applied.

<Toggle Operation>

The XC6413/14 A and B series have a built-in toggle ON/OFF switch which repeats an on/off operation via the EN pin's leading edge signal when the EN logic is HIGH active, and via the EN pin's falling edge signal when the EN logic is LOW active (Please also refer the figure below). The EN input signal duration should be over 500nsec. If the EN input signal is less than 500nsec, it is possible that the circuit fails to respond and the toggle function does not operate. To operate the toggle function properly when the EN pin voltage noise is large, a RC filter should be used to reduce the noise in the signal to the EN pin. XC6413/14B series can reset FF (flip flop), used for the toggle operation, internally by using a signal of the detector function. The signal of the detector function resets FF after converted to 1 shot signal in the IC. The regulator block start to output when a signal is given via the EN pin again.

[XC6413 Series]

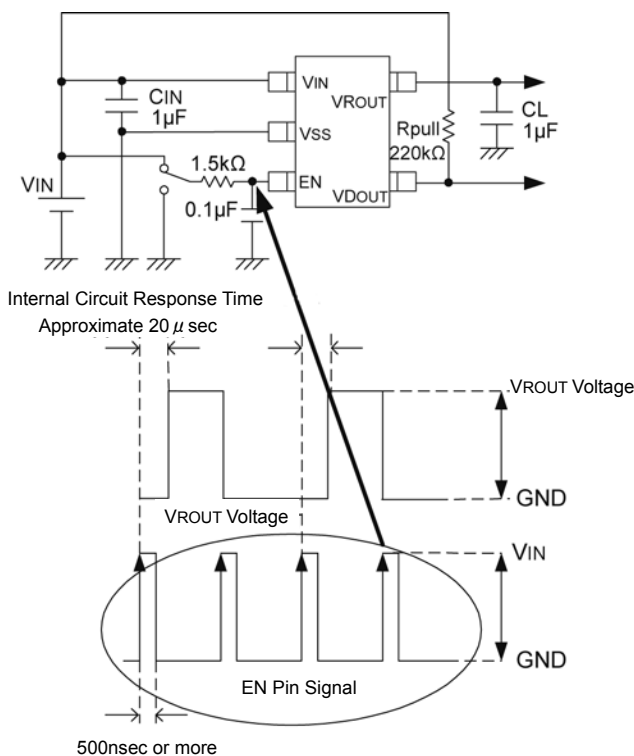

[XC6414 Series]

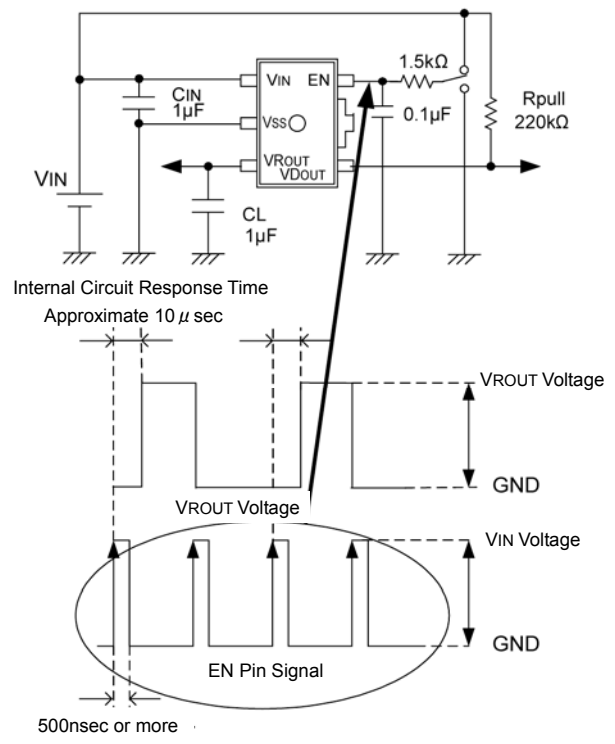

EN Logic High Active

■ OPERATIONAL EXPLANATION (Continued)

<Toggle Operation (Continued) >

For the XC6403/04B series, there are two types of toggle selection; one is a T-type flip-flop (T-FF) used for toggle operation which can be reset internally by a signal directly from the voltage detector (V_{IN} Sense type only. See also the Selection Guide). The other type is where the reset is applied internally through a one shot pulse circuit (V_{IN} , V_{ROUT} type only. See also the Selection Guide). The type, which applies the reset directly via the signal from the voltage detector function, applies the voltage detector comparator's output signal (reset signal) to the reset of T-FF reset, and turns the VR output OFF when the input voltage decreases below the detect voltage due to battery consumption, etc.. In order to return the VR output, apply a voltage larger than the release voltage to V_{IN} and input a toggle signal to the T-FF. In the case where input voltage is below the release voltage, the VR output does not return even though the toggle signal is input into the T-FF.

The type which applies the reset signal to the T-FF internally via a one-shot pulse circuit changes the voltage detector comparator output signal to a one-shot signal internally. Like the type which applies the reset directly via the signal from voltage detector function, this type also applies the reset to the T-FF and sets the VR output to OFF when the input voltage (V_{IN} Sense type) and output voltage (V_{ROUT} Sense type) drop below the detect voltage level. This type can return the VR output by inputting a toggle signal, even when the Sense pin voltage (V_{IN} or V_{ROUT} pin voltage) is below the release voltage. Please refer to the block diagram below and the timing chart on the following page. Please choose the option suitable to the application.

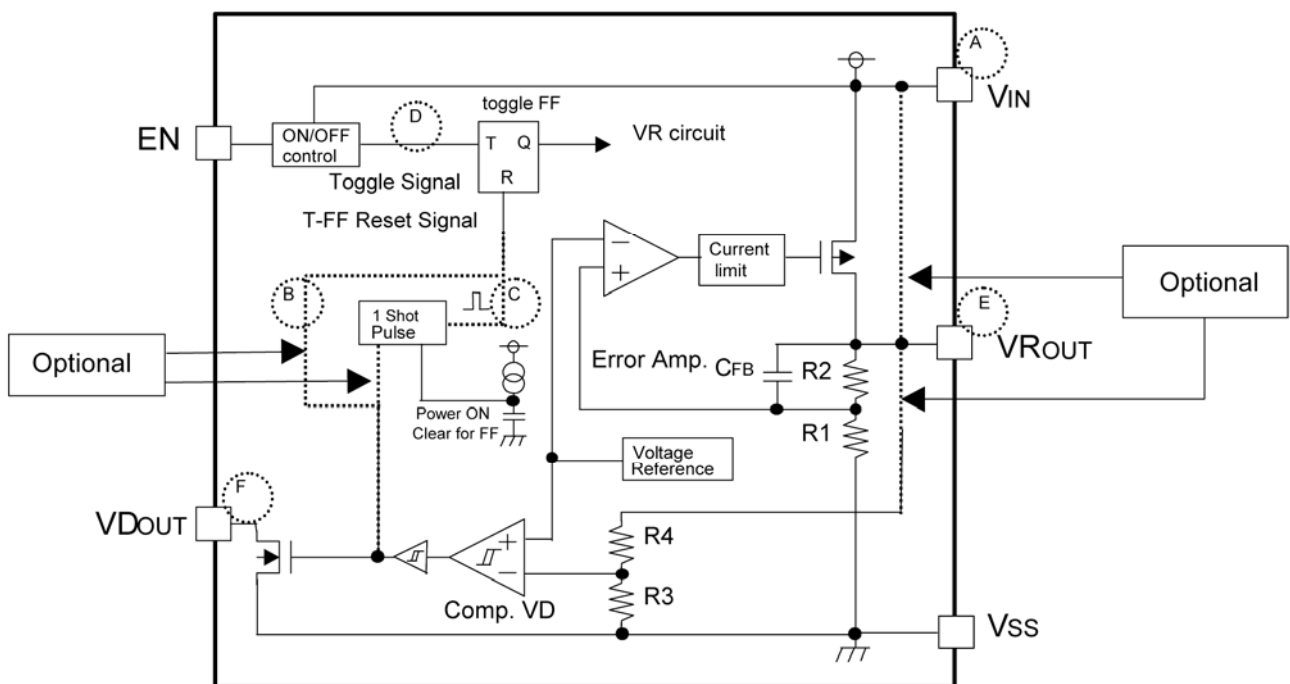

Block diagram for the XC6413 / 14B series' timing chart

TIMING CHART

XC6413/14B Series

- Using the VD output level signal as the reset signal of T-FF (VD Sense = VIN PIN)

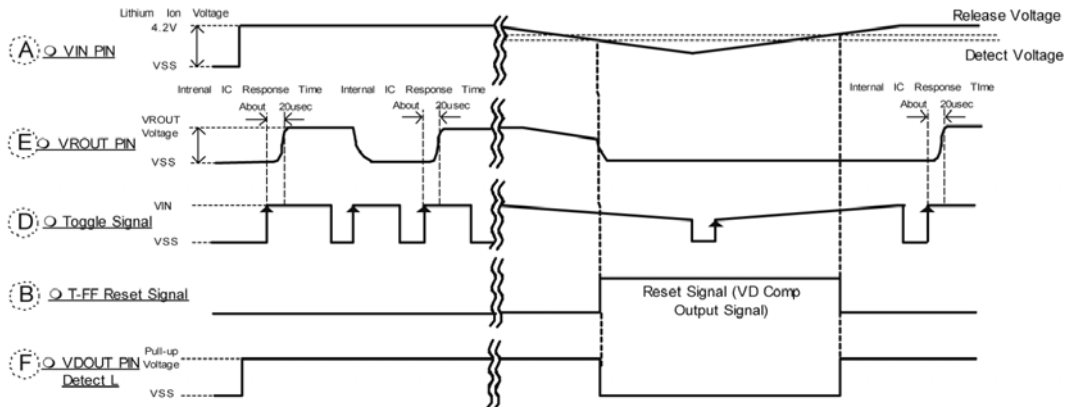

- Changing the VD output level signal into a one shot pulse to use T-FF as the reset signal (VD Sense = VIN PIN)

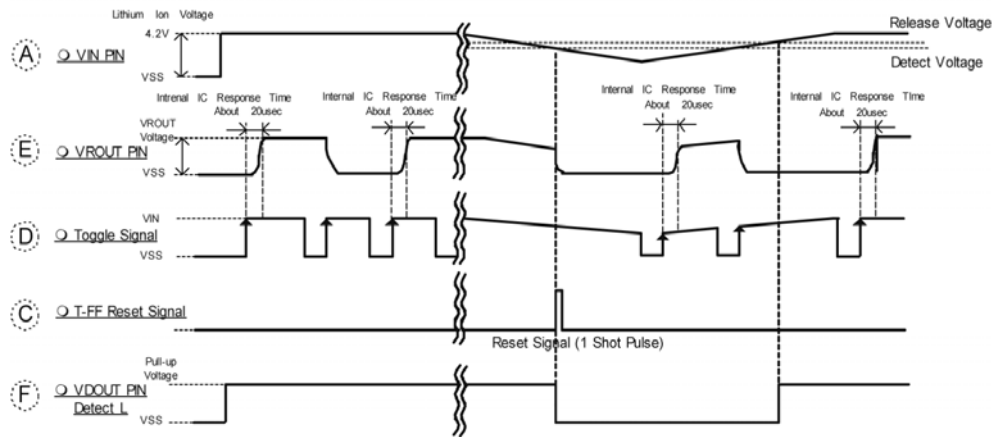

- Changing the VD output level signal into a one shot pulse to use T-FF as the reset signal (VD Sense = VROUT PIN)

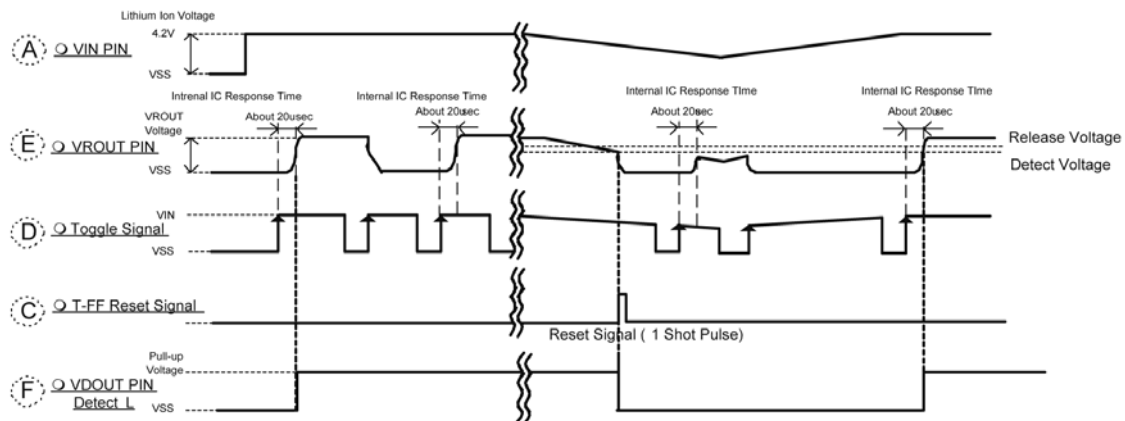

○ The circled letters correspond to those shown on the block diagram

NOTES ON USE

1. Please use this IC within the stated absolute maximum ratings. The IC is liable to malfunction should the ratings be exceeded.
2. Where wiring impedance is high, operations may become unstable due to noise and/or phase lag depending on output current. Please strengthen VIN and VSS wiring in particular.
3. Please wire the input capacitor (CIN) and the output capacitor (CL) as close to the IC as possible. Should rapid input fluctuation or load fluctuation occur, please increase the capacitor value such as CIN or CL to stabilize the operation.

PACKAGING INFORMATION

● SOT-25

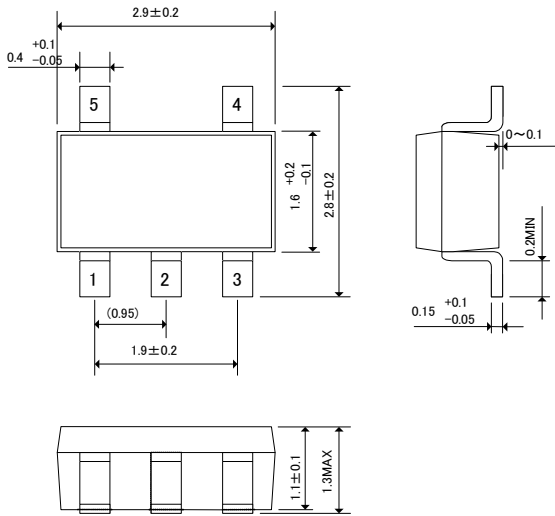

● SOT89-5

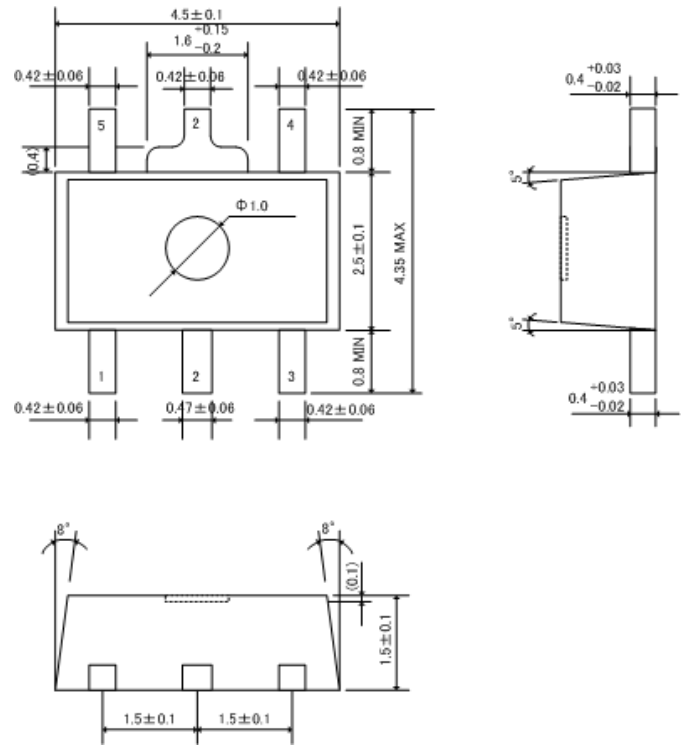

● USP-6B

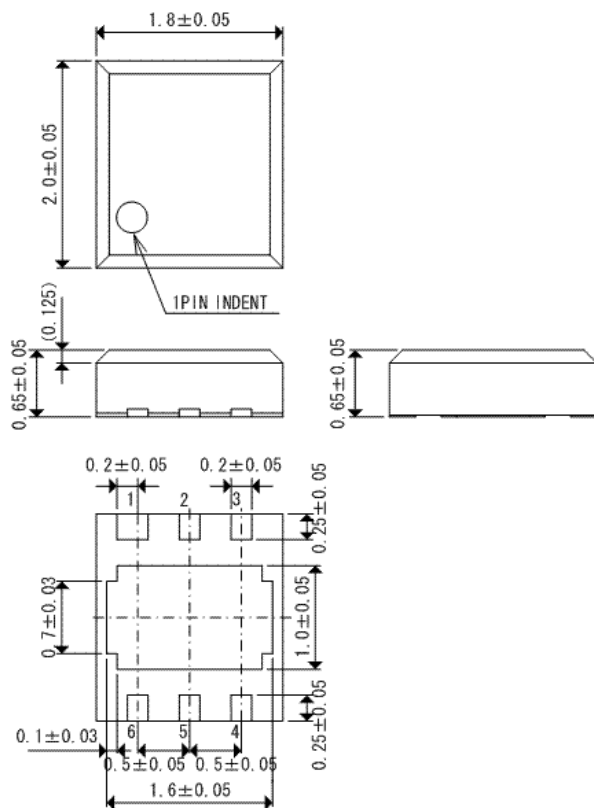

● USP-6B Reference Pattern Layout

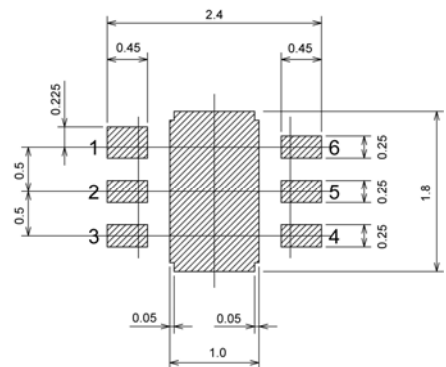

● USP-6B Reference Metal Mask Design

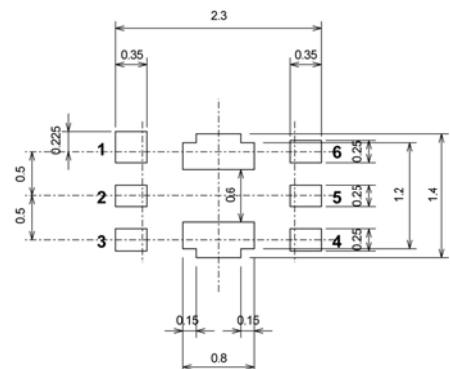

MARKING RULE

● SOT-25, SOT-89-5

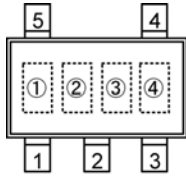

SOT-25
(TOP VIEW)

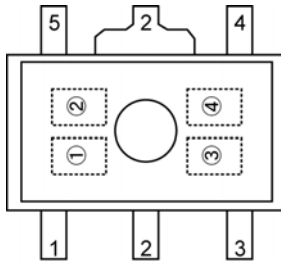

SOT-89-5
(TOP VIEW)

① represents product series

MARK	PRODUCT SERIES
<u>D</u>	XC6413xxxxxx
<u>E</u>	XC6414 xxxxxx

②③ represents internal sequential number

01~09, 10~99, A0~A9, B0~B9, Z9

(G, I, J, O, Q, W excluded)

The two digits show a combination of "Operational Function", "Type of Regulator" and "Output Voltage & Detect Voltage".

The same digits are used between the type of packages.

④ represents production lot number

0~9, A~Z repeated. (G, I, J, O, Q, W excluded.)

MARKING RULE (Continued)

● USP-6B

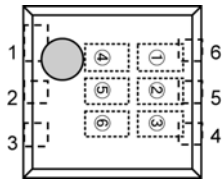

USP-6B
(TOP VIEW)

① represents product series

MARK	PRODUCT SERIES
6	XC6413xxxxxx
7	XC6414xxxxxx

② represents optional functions

MARK	OPTIONAL FUNCTIONS	PRODUCT SERIES
A	Toggle and EN Function	XC6413/14Axxxxx
B	Toggle, EN Function, VD signal/VR OFF Function	XC6413/14Bxxxxx
C	EN Function	XC6413/14Cxxxxx
D	CE Function	XC6413/14Dxxxxx
E	VSEN Pin	XC6413/14Exxxxx
F	Cd Pin	XC6413/14Fxxxxx

③ represents product type

MARK	EN/CE FUNCTION	EN / CE LOGIC	PULL UP/DOWN RESISTANCE	VD SENSE PIN	VD OUTPUT LOGIC	PRODUCT SERIES
A	Function	High Active	Pull-Down Function	VIN	Detect L	XC6413/14xAxxxx
B	Function	High Active	Pull-Down Function	VIN	Detect H	XC6413/14xBxxxx
C	Function	High Active	Pull-Down Function	VR _{OUT}	Detect L	XC6413/14xCxxxx
D	Function	High Active	Pull-Down Function	VR _{OUT}	Detect H	XC6413/14xDxxxx
E	Function	High Active	Nonfunctional	VIN	Detect L	XC6413/14xExxxx
F	Function	High Active	Nonfunctional	VIN	Detect H	XC6413/14xFxxxx
H	Function	High Active	Nonfunctional	VR _{OUT}	Detect L	XC6413/14xHxxxx
K	Function	High Active	Nonfunctional	VR _{OUT}	Detect H	XC6413/14xKxxxx
L	Function	Low Active	Pull-Up Function	VIN	Detect L	XC6413/14xLxxxx
M	Function	Low Active	Pull-Up Function	VIN	Detect H	XC6413/14xMxxxx
N	Function	Low Active	Pull-Up Function	VR _{OUT}	Detect L	XC6413/14xNxxxx
P	Function	Low Active	Pull-Up Function	VR _{OUT}	Detect H	XC6413/14xPxxxx
R	Function	Low Active	Nonfunctional	VIN	Detect L	XC6413/14xRxxxx
S	Function	Low Active	Nonfunctional	VIN	Detect L	XC6413/14xSxxxx
T	Function	Low Active	Nonfunctional	VR _{OUT}	Detect H	XC6413/14xTxxxx
U	Function	Low Active	Nonfunctional	VR _{OUT}	Detect H	XC6413/14xUxxxx
V	Nonfunctional	-	-	VIN / VSEN	Detect L	XC6413/14xVxxxx
X	Nonfunctional	-	-	VR _{OUT} /VSEN	Detect H	XC6413/14xXxxxx
Y	Nonfunctional	-	-	VR _{OUT} /VSEN	Detect L	XC6413/14xYxxxx
Z	Nonfunctional	-	-	VR _{OUT} /VSEN	Detect H	XC6413/14xZxxxx

④,⑤ represents output Voltage ex.)

MARK		OUTPUT VOLTAGE		PRODUCT SERIES
④	⑤	VR _{OUT} (V)	VD _{OUT} (V)	
0	1	3.2	2.5	XC6413/14**01**

⑥ represents production lot number
0 to 9,A to Z repeated (G, I, J, O, Q, W excluded)
Note: No character inversion used.

1. The products and product specifications contained herein are subject to change without notice to improve performance characteristics. Consult us, or our representatives before use, to confirm that the information in this datasheet is up to date.
2. We assume no responsibility for any infringement of patents, patent rights, or other rights arising from the use of any information and circuitry in this datasheet.
3. Please ensure suitable shipping controls (including fail-safe designs and aging protection) are in force for equipment employing products listed in this datasheet.
4. The products in this datasheet are not developed, designed, or approved for use with such equipment whose failure or malfunction can be reasonably expected to directly endanger the life of, or cause significant injury to, the user.
(e.g. Atomic energy; aerospace; transport; combustion and associated safety equipment thereof.)
5. Please use the products listed in this datasheet within the specified ranges.
Should you wish to use the products under conditions exceeding the specifications, please consult us or our representatives.
6. We assume no responsibility for damage or loss due to abnormal use.
7. All rights reserved. No part of this datasheet may be copied or reproduced without the prior permission of TOREX SEMICONDUCTOR LTD.

TOREX SEMICONDUCTOR LTD.